

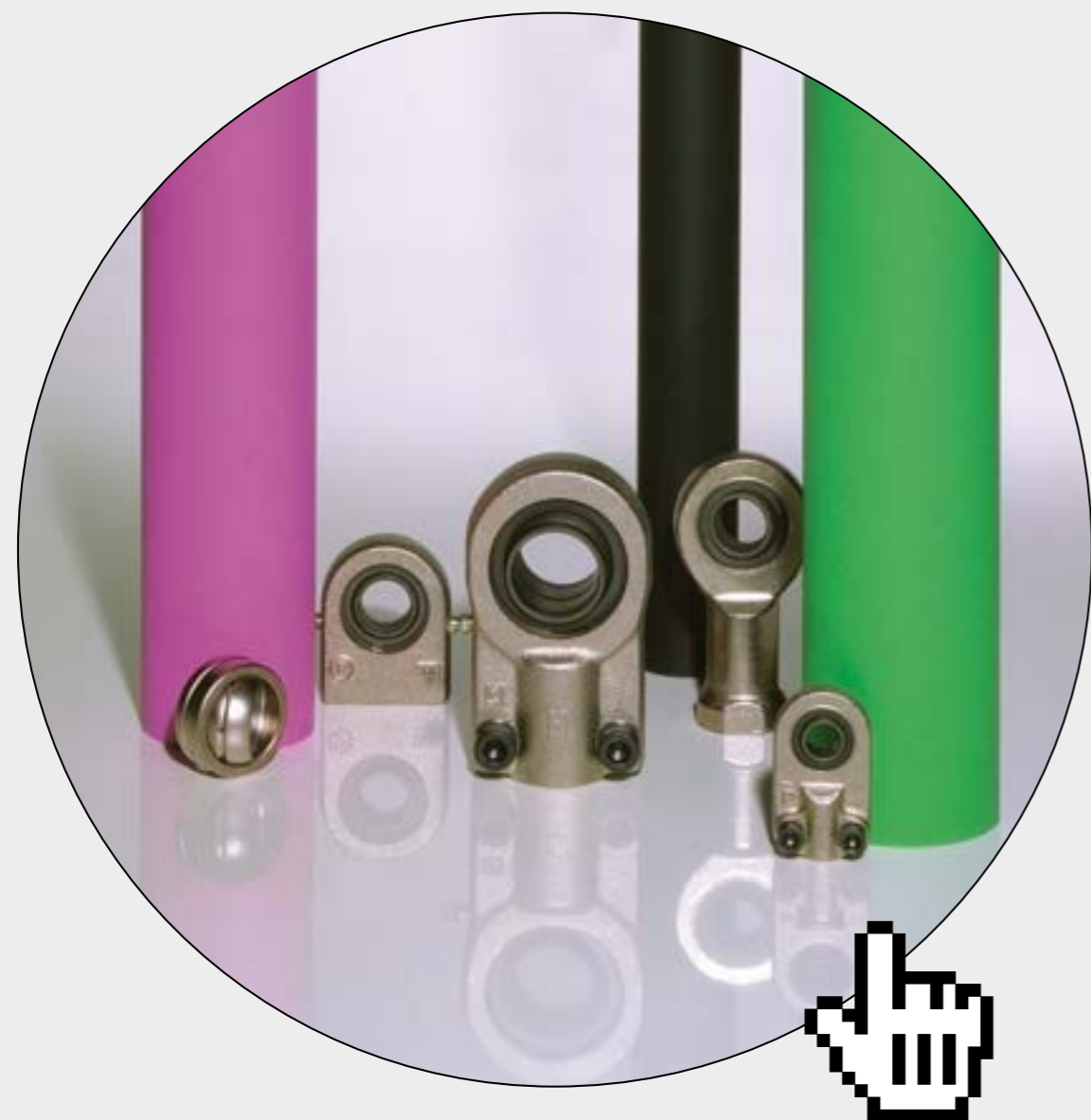

[www.pavarinicomponents.com](http://www.pavarinicomponents.com)

# TERMINALI A SNODO ROD ENDS



GAMMA DEI TERMINALI A SNODO - TABELLE CON CARATTERISTICHE COSTRUTTIVE E APPLICATIVE  
 PRODUCT RANGE - TABLE OF DESIGN AND APPLICATION FEATURES

PAG.

4-6 ITA  
10-12 ENG

INDICAZIONI PER LA SCELTA DEL TIPO, CALCOLO DELLA DURATA E DIMENSIONAMENTO,  
 TEMPERATURA DI FUNZIONAMENTO, TOLLERANZE DI ACCOPPIAMENTO RACCOMANDATE  
 ADVICE ABOUT CHOICE ON ROD-END TYPE, CALCULATION OF DURATION AND SIZING, OPERATING  
 TEMPERATURE, RECOMMENDED COUPLING TOLERANCE (BEARINGS/ROD ENDS)

7-9 ITA  
13-15 ENG

TABELLA COMPARATIVA TERMINALI A SNODO  
 CROSS REFERENCE ROD ENDS

16

TERMINALI CON ACCOPPIAMENTO ACCIAIO / ACCIAIO CON FILETTATURA INTERNA ED ESTERNA  
 TERMINALI CON ACCOPPIAMENTO ACCIAIO/ACCIAIO CON ESTREMITA' A SALDARE  
 RICHIEDENTI MANUTENZIONE  
 ROD ENDS WITH STEEL/STEEL COUPLING, WITH INTERNAL AND EXTERNAL THREADS/ROD ENDS WITH  
 STEEL/STEEL COUPLING WITH WELDING ENDS REQUIRING MAINTENANCE

17-28/31

TERMINALI CON ACCOPPIAMENTO ACCIAIO / TESSUTO PTFE CON FILETTATURA INTERNA  
 ED ESTERNA NON RICHIEDENTI MANUTENZIONE  
 MAINTENANCE FREE ROD ENDS WITH STEEL/PTFE COUPLING  
 WITH INNER AND OUTER/THREADS

29-31

TERMINALI A SNODO SFERICO AD ESTREMITA' RETTANGOLARE O ROTONDA DA SALDARE O CON  
 FILETTATURA INTERNA PER CILINDRI IDRAULICI  
 BALL JOINT TERMINAL WITH WELDING SQUARE BASE OR ROUND BASE  
 OR INNER THREAD FOR HYDRAULIC CYLINDERS

32-37

BASI OSCILLANTI E BORCHIE A SALDARE  
 SWINGING ENDS AND FEMALES WELD BOSS

38-39

FORCELLE, PERNI E ANELLI DI TENUTA (SEEGER)  
 FORKS, PINS AND RINGS (SEEGER)

40-42

## GAMMA TERMINALI A SNODO

TERMINALE	TIPO	PAGINA
	TS...C	17

**CARATTERISTICHE COSTRUTTIVE** Terminale a snodo con superficie di saldatura circolare, snodo sferico secondo ISO 12240-4, serie E, forma S. Corpo in acciaio S355JR UNI EN 10025 con spina di centraggio sul fondo del gambo e smusso di saldatura a 45°. Lo snodo sferico è fissato alla testa mediante cianfrinatura anulare bilaterale. Dotato di ingrassatore per la lubrificazione dal diametro 25 dello snodo.

**CAMPO DI APPLICAZIONE** Terminale a snodo per la produzione economica di elementi d'attacco cilindrici. Applicabile tanto all'estremità dello stelo quanto sul fondo del cilindro.

TERMINALE	TIPO	PAGINA
	TS...N	18

**CARATTERISTICHE COSTRUTTIVE** Terminale a snodo da saldare in acciaio S355JR UNI EN 10025. Sono a base rettangolare senza spina di centraggio. Snodo sferico sec. ISO 12240-1 serie dimensionale E fissato alla testa per mezzo di anelli elastici. Dotato di ingrassatore per la lubrificazione dal diametro 20 dello snodo.

**CAMPO DI APPLICAZIONE** Terminale a snodo di tipo molto massiccio da saldare sul fondo dei cilindri oleodinamici applicabile nella costruzione di impianti e gruppi ed in altre esecuzioni saldate. Lo snodo sferico è smontabile.

TERMINALE	TIPO	PAGINA
	TS...CE-N	19

**CARATTERISTICHE COSTRUTTIVE** Terminale per oleodinamica da saldare, in acciaio S355JR UNI EN 10025. A base rettangolare senza spina di centraggio con caratteristiche analoghe alla serie TS...N dal quale si differenzia per lo snodo sferico. E' stato infatti realizzato in ottemperanza alle prescrizioni CETOP - ISO 12240-1, serie W. Dotato di ingrassatore per la lubrificazione dal diametro 20 dello snodo.

**CAMPO DI APPLICAZIONE** Per cilindri oleodinamici realizzati secondo le normative CETOP, DIN 24333-24336 ed ISO 6020/1 e 6022.

TERMINALE	TIPO	PAGINA
	TS...NF	20

**CARATTERISTICHE COSTRUTTIVE:** Terminale a snodo in acciaio S355JR UNI EN 10025 comprensivo di fondello collegabile direttamente alla canna del cilindro mediante saldatura. Sono a base circolare, senza spina di centraggio. Snodo sferico secondo ISO 12240-1 serie dimensionale E, fissato alla testa per mezzo di anelli elastici. Dotato di ingrassatore per la lubrificazione.

**CAMPO DI APPLICAZIONE:** Terminale a snodo di tipo molto massiccio da saldare su cilindri oleodinamici, applicabile nella costruzione di impianti e gruppi e in altre esecuzioni saldate. Lo snodo sferico è smontabile.

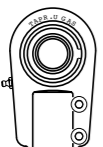
TERMINALE	TIPO	PAGINA
	TAPR...U GAS	21

**CARATTERISTICHE COSTRUTTIVE** Terminale a snodo per oleodinamica in acciaio C45 a filettatura interna in esecuzione massiccia - filettatura lunga caratterizzato dal fatto di avere un'interasse maggiore rispetto alla tipologia TAPR...U e TAPR...N. Corpo in acciaio C 45 stampato sino alla dimensione 60; dalla dimensione 70 il corpo viene ricavato in ghisa sferoidale. Dotato di snodo sferico secondo la normativa ISO 12240-1, serie E, fissato nella testa mediante anelli elastici. Dotato di ingrassatore con filettatura Gas per la lubrificazione. Il gambo è fessurato in modo da originare un dispositivo di bloccaggio filettatura mediante due viti ad esagono incassato secondo la normativa DIN 912.

**CAMPO DI APPLICAZIONE** Terminale a snodo con forma particolare per il settore di applicazione dei cilindri oleodinamici. La struttura massiccia consente interassi di attacco massimi con massimo sfruttamento della corsa.

## GAMMA TERMINALI A SNODO

TERMINALE	TIPO	PAGINA
	TAPR...N	22

**CARATTERISTICHE COSTRUTTIVE** Terminale a snodo per oleodinamica in acciaio C45 a filettatura interna in esecuzione massiccia - filettatura corta. Corpo in acciaio C 45 stampato. Dal Ø nominale 90 il corpo viene ricavato in ghisa sferoidale. Snodo sferico sec. ISO 12240-1, serie E fissato nella testa mediante anelli elastici. Dotato di ingrassatore per la lubrificazione.

**CAMPO DI APPLICAZIONE** Terminale a snodo con forma particolare per il settore di applicazione dei cilindri oleodinamici. La struttura massiccia consente interassi di attacco minimi con massimo sfruttamento della corsa.

TERMINALE	TIPO	PAGINA
	TAPR...U	23

**CARATTERISTICHE COSTRUTTIVE** Terminale a snodo per l'oleodinamica in acciaio C45 uguale alla serie TAPR...N ma con gambo fessurato tale da originare un dispositivo di bloccaggio filettatura mediante due viti ad esagono incassato sec. DIN 912. Dotato di ingrassatore per la lubrificazione.

**CAMPO DI APPLICAZIONE** Terminale a snodo corrispondente alla serie TAPR...N, però da fissare alla filettatura dello stelo mediante dispositivo di bloccaggio.

TERMINALE	TIPO	PAGINA
	TAPR...CE	24

**CARATTERISTICHE COSTRUTTIVE** Terminale a snodo per oleodinamica in acciaio C45 a filettatura interna più lunga della serie TAPR...N e TAPR...U corrispondente a DIN 24338 - ISO 6982. Corpo in acciaio C 45 stampato. Dal Ø70 in poi il corpo viene ricavato in ghisa sferoidale. Lo snodo sferico secondo ISO 12240-1, serie W è fissato alla testa mediante anelli elastici. Gambo fessurato tale da originare un dispositivo di bloccaggio della filettatura mediante due viti ad esagono incassato sec. DIN secondo 912- Dotato di ingrassatore per la lubrificazione.

**CAMPO DI APPLICAZIONE** Terminale a snodo sec. DIN 24338 per cilindri oleodinamici sec. norme corrispondenti alla raccomandazione CETOP RP 58 H e DIN 24333-24336 ed ISO 6020/1 - 6022

TERMINALE	TIPO	PAGINA
	TAPR...S	25

**CARATTERISTICHE COSTRUTTIVE** Terminale a snodo per oleodinamica in acciaio C45 con filettatura interna corrispondente a DIN 24555 - ISO 8133. Corpo in acciaio C 45. Snodo sferico secondo ISO 12240-1, fissato mediante cianfrinatura anulare bilaterale, serie dimensionale E. Gambo fessurato tale da originare il bloccaggio della filettatura mediante due viti ad esagono incassato (disposte agli angoli) sec. DIN 912. Dotato di ingrassatore per la lubrificazione dal diametro 25 dello snodo.

**CAMPO DI APPLICAZIONE** Testa a snodo per cilindri oleodinamici. norma da 160 bar, sec. ISO 6020/II.

TERMINALE	TIPO	PAGINA
	TFI...FK	26
	TFI...FK MAGGIORATO	26
	TFE...MK	28
	TFE...MK MAGGIORATO	28
	TFI...U	31
	TFI...M	27

**CARATTERISTICHE COSTRUTTIVE** Terminali a snodo costruiti in acciaio C 45, (zincato). Filettatura interna nella serie TFI..., esterna nella serie TFE... . Disponibili anche con filettatura sinistrorsa nelle due serie. Questi terminali a norme ISO 12240-4, serie E tipo M, sono rilubrificabili attraverso un ingrassatore o un foro e possono essere forniti con snodo sferico nella versione 2RS e con filetto maggiorato. Vedi tipo TFI - TFE maggiorato dal Ø nominale 40 al Ø80.

**CAMPO DI APPLICAZIONE** Indicati per funzionamenti con elevati carichi alternati e carichi d'urto. Lunga filettatura di registrazione.

GAMMA TERMINALI A SNODO

TERMINALE	TIPO	PAGINA	
	TFI ... FKB	...T-2RS	29
		...T-2RS MAGGIORATO	29
	TFE... MKB	...T-2RS	30
		...T-2RS MAGGIORATO	30
	TFI ... UB	31	

**CARATTERISTICHE COSTRUTTIVE** Terminali a snodo costruiti in acciaio C45, (zincati). Disponibili con filettatura interna nella serie TFI..., ed esterna nella serie TFE... norme ISO 12240-4, serie E tipo M. Lo snodo sferico ha un anello interno in acciaio con uno strato di strisciamento in PTFE. Sono esenti da lubrificazione, e possono essere forniti con snodo sferico nella versione 2RS e con filetto maggiorato. Vedi tipo TFI - TFE maggiorato dal Ø nominale 40 al Ø80.

**CAMPO DI APPLICAZIONE** Terminali a snodo non richiedenti manutenzione, in alternativa alla serie TFI / TFE...PW. Settori di applicazione per condizioni di funzionamento normale (carico unilaterale e limitatamente alternato - movimento lento per angoli di oscillazione da piccoli a medi).

TERMINALI A SNODO PER APPLICAZIONI AGRICOLE

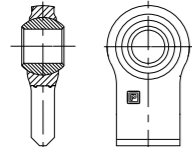
TERMINALI A SNODO PER APPLICAZIONI AGRICOLE	TIPO	PAGINA
	SR...	32-37

BASI OSCILLANTI, BORCHIE, FORCELLE, PERNI E ANELLI DI TENUTA (SEEGER)

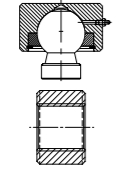
BASI OSCILLANTI E BORCHIE	TIPO	PAGINA
	BO...	38
	BS...	39

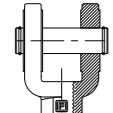
FORCELLA	TIPO	PAGINA
	KLP...	40

PERNO	TIPO	PAGINA
	PERNO KP...	40

FORCELLA	TIPO	PAGINA
	FF... FORCELLE FILETTATE / FS... FORCELLE SALDARE	41

ANELLI DI TENUTA (SEEGER)	TIPO	PAGINA
	I...SB / I...DIN / E...DIN	42

ROD END RANGE

ROD	TYPE	PAGE
	TAPR...N	22

**DESIGN FEATURES** Hydraulic rod end in steel C45 with Internally threaded connector for heavy performance, relubricated by way of a grease lubricator in the terminal and through the pivot. The body is made of C45 steel forging. From 90 diameter is made of cast iron. Bearing according to ISO 12240-1 series E, fixed at the head with rings. With grease nipple.

**FIELD OF APPLICATION** Particularly recommended for hydraulic cylinders, where our design allows maximum stroke length with minimum closed centers.

ROD	TYPE	PAGE
	TAPR...U	23

**DESIGN FEATURES** Hydraulic end in steel C45 with an internally threaded connector, relubricated through a grease lubricator in the rod end and through the pivot. It differs from the previous type because the connector is grooved so as to produce a locking device with two hexagonal screws, according to DIN 912.

**FIELD OF APPLICATION** Same applications are the TAPR...N series but with the advantage that it guarantees better and greater fixing to the pivot thread.

ROD	TYPE	PAGE
	TAPR...CE	24

**DESIGN FEATURES** Hydraulic rod end in steel C45 with connector having a longer internal thread than that of the TAPR...N and TAPR ...U series. Designed with a threaded location system given that the connector is grooved, can be relubricated through a grease lubricator in the end through the pivot. This type was designed in accordance with regulation DIN 24338 - ISO 6982 for assembly on to hydraulic cylinders. The internal bearing (according to ISO 12240-1 series W) is characterised by cylindrical extension on all sides so that the diameter of the bore corresponds with the width of the bearing. The body is made from C45 steel. From diameter 70mm is made from rounded cast iron.

**FIELD OF APPLICATION** For cylinders made in accordance with CETOP RP 58 H, DIN 24333, DIN 24336, ISO 6020/1 and ISO 6022; can be used also for the other types.

ROD	TYPE	PAGE
	TAPR...S	25

**DESIGN FEATURES** Hydraulic ends in steel C45 with internally threaded connector, relubricated by way of a grease lubricator from Ø 25 in the housing and through the pivot. According to DIN 24555 - ISO 8133, the body is made in C45 steel from diam. 12 to diam. 50. From diam. 60 to diam. 100 is made from rounded cast-iron. Spherical plain bearings according to ISO 12240-1 series E. The connector is grooved so as to produce a locking device with two hexagonal screws according to DIN 912

**FIELD OF APPLICATION** These are recommended for 160 bar hydraulic cylinders according to DIN 24554-150 6020/2.

ROD	TYPE	PAGE	
	TFI...FK	...FK-2RS	26
	TFI...FK MAGGIORATO	...FK-2RS MAGGIORATO	26
	TFE... MK	...MK-2RS	28
	TFE...MK MAGGIORATO	...MK-2RS MAGGIORATO	28
	TFI...U		31
	TFI...M		27

**DESIGN FEATURES** Regulation ISO 12240-4 series E type M, produced in C45 steel zinc plated to protect against corrosion. Available with an internal thread (TFI - series) or external (TFE series), right or left. Lubricatable through a grease nipple or a hole. Also with the version [ bearing- (2RS) ]. Available also TFI-TFE higher diameter thread from Ø 40 to Ø 80.

**FIELD OF APPLICATION** End recommended for application with high alternate loads and shock loads. Long registered thread.

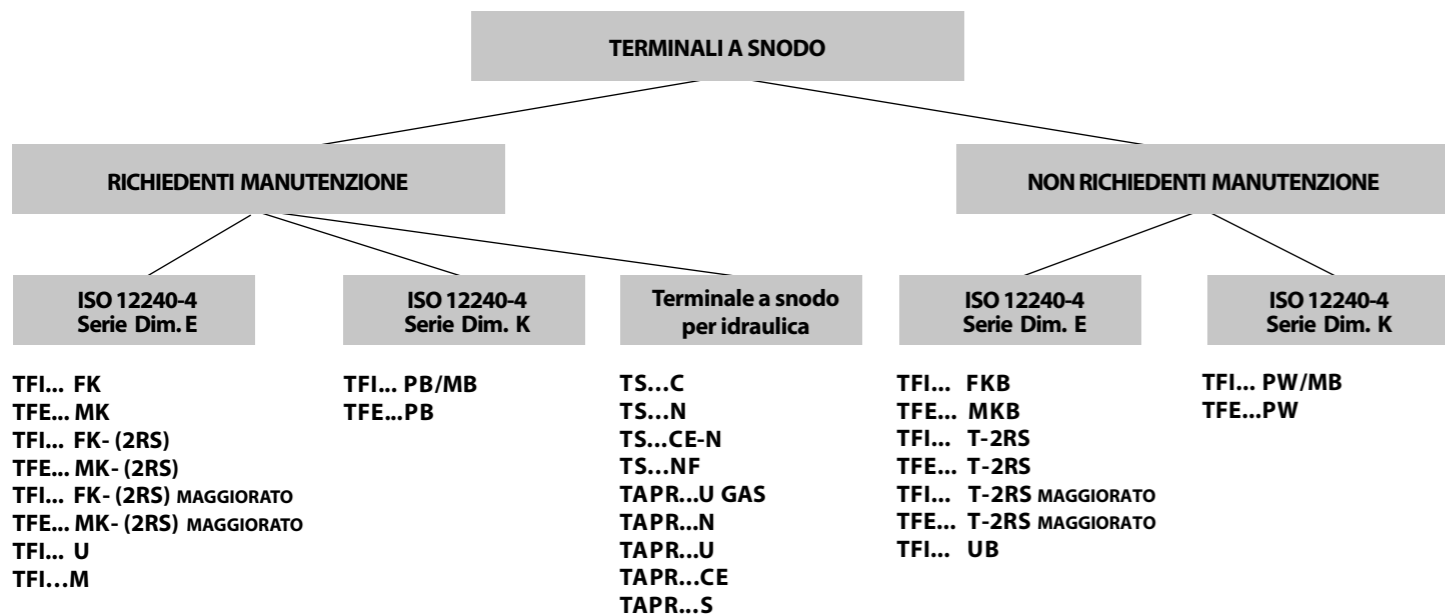

I terminali a snodo sono costituiti da un corpo a testa e da uno snodo sferico che è montato fisso nel corpo stesso. In tale esecuzione essi formano elementi di supporto e di collegamento pronti per il montaggio, che possono venire integrati senza problemi nelle costruzioni previste grazie alle loro superfici di saldatura o filettature.

**SCELTA DEL TIPO DI TERMINALE**

Tutti i terminali a snodo da noi realizzati hanno molteplici applicazioni e anche se, le esecuzioni sono state studiate e realizzate per soddisfare diverse esigenze applicative, non è possibile stabilire norme generali per la scelta del tipo da utilizzare. Tuttavia le informazioni seguenti possono mettere in evidenza i dati più importanti per la scelta del terminale e del tipo di snodo con l'accoppiamento più idoneo per le superfici di lavoro. Esistono comunque alcuni elementi fondamentali da prendere in esame e sono:

**CARICO MANUTENZIONE TEMPERATURA DI FUNZIONAMENTO ANGOLO DI RIBALTAMENTO**

**CARICO**  
Per poter determinare tipo, dimensioni e materiale delle superfici di lavoro di un terminale o di uno snodo sferico è di importanza fondamentale conoscere l'entità e della direzione del carico nonché il modo con cui questo agisce.

- **Carico Radiale** - Tutti gli snodi sferici radiali possono sopportare carichi radiali elevati e, entro certi limiti, anche carichi assiali in ambo i sensi agenti contemporaneamente.
- **Carico Assiale** - Gli snodi sferici assiali possono sopportare carichi assiali molto elevati agenti in un solo senso e, entro certi limiti, anche carichi radiali agenti contemporaneamente.
- **Carichi che agiscono in un solo senso** - Quando il carico agisce sempre nella stessa direzione e nello stesso senso, la zona di carico si trova sempre dalla stessa parte dello snodo. Per le applicazioni dove si hanno sollecitazioni di tipo statico, oppure dove lo snodo è soggetto a piccolissimi movimenti di assestamento sotto carico, sollecitazioni quasi statiche, si raccomanda l'impiego di snodi sferici con accoppiamento acciaio su acciaio. Nel caso in cui lo snodo sia sottoposto anche a sollecitazioni dinamiche sono da preferirsi gli snodi sferici non richiedenti manutenzione.
- **Carichi che agiscono in senso alternato** - Nelle applicazioni dove il carico agisce in senso alternato, le due zone di lavoro dello snodo a 180° tra di loro vengono alternativamente caricate e scaricate ad ogni movimento di oscillazione. In questo caso si raccomanda l'utilizzo di snodi sferici con accoppiamento acciaio su acciaio. Gli snodi sferici non richiedenti manutenzione possono essere impiegati solo entro certi limiti.

- **I FATTORI DI CARICO NELLE TABELLE DEI TERMINALI SI RIFERISCONO AL CORPO TERMINALE ACCOPPIATO CON SNODO SFERICO "PAVARINI" MARCHIATO "LSP"**

**MANUTENZIONE**

Normalmente gli snodi sferici acciaio su acciaio devono venire lubrificati ad intervalli regolari per garantire durata e corretto funzionamento. Se viene richiesto un funzionamento senza manutenzione oppure per posizionamenti dove non è possibile garantire una regolare lubrificazione sono da utilizzare snodi sferici esenti da manutenzione. In questo caso vengono usati particolari tipi di materiali per le superfici di strisciamento che consentono un esercizio senza manutenzione.

**ANGOLO DI RIBALTAMENTO**

L'angolo di ribaltamento possibile varia in funzione della serie dimensionale, dell'esecuzione e delle dimensioni dello snodo sferico. Sono sempre indicati nelle relative tabelle.

**CALCOLO DELLA DURATA E DIMENSIONAMENTO**

La durata di uno snodo o di un terminale è il numero di oscillazioni complete, o il numero di ore di funzionamento. Per poter operare correttamente nella scelta e nel dimensionamento si devono considerare diversi fattori che influiscono sulla scelta stessa. I parametri da considerare riguardano:

**CARICO MOVIMENTO DURATA LUBRIFICAZIONE**

Altri fattori, come carichi, urti, impurità, ambiente di lavoro, sono difficilmente valutabili. Per il calcolo della durata tecnica consideriamo il carico (F) coincidente al valore di carico della durata P, quando la forza agisce in senso puramente radiale e l'entità e la direzione non variano durante il funzionamento F=P=FR (vedi figura).

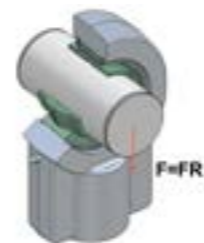

Nel caso in cui le sollecitazioni siano contemporaneamente assiali e radiali, occorre introdurre un valore di calcolo P nel calcolo della durata, che tenga in considerazione l'influenza delle forze agenti combinate. (vedi figura)

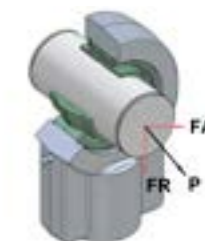

Calcolo del valore P  
 $P = K_f FR$   
 dove:  
 P = Carico dinamico equivalente in KN  
 FR = Carico radiale in KN  
 FA = Carico assiale in KN  
 Kf = Coefficiente di correzione che in questo caso è ricavabile con questa funzione:

$$K_f = 0,978 \cdot 21,546 \frac{FA}{FR}$$

**MOVIMENTO E FREQUENZA**

La presenza del movimento e della sua frequenza caratterizza le condizioni dinamiche di impiego. (vedi figura)



Dalla figura è possibile identificare tre possibilità di movimento espresse con i seguenti parametri:  
 - angolo di oscillazione  $\beta$   
 - angolo di ribaltamento  $\alpha$   
 - angolo di movimento  $\beta_1$  nel caso si abbiano movimenti combinati di oscillazione e di ribaltamento.

Occorre calcolare in modo seguente  $\beta_1 = \sqrt{\beta^2 + \alpha^2}$

**FREQUENZA**

Esprime nell'unità di tempo il numero di movimenti e dimensionalmente è espressa in  $\text{min}^{-1}$ . E' considerata nel calcolo solo se l'applicazione ha un funzionamento continuo senza fermate periodiche.

**COEFFICIENTE DI CARICO**

Il coefficiente di carico dinamico C viene utilizzato per il calcolo quando gli snodi sferici o i terminali sono sottoposti a sollecitazioni dinamiche, cioè quando sotto l'azione del carico si hanno movimenti oscillanti di ribaltamento o di rotazione. Per l'utilizzo di questo parametro è indispensabile che il carico agisca in senso radiale. Nell'applicazione dinamica rappresenta il massimo carico ammissibile ed il suo completo sfruttamento non ci consente durate molto lunghe. Normalmente il rapporto C/P si colloca in un campo compreso da 1 a 5 e comunque non inferiore a 1. Il coefficiente di carico statico Co rappresenta il carico statico massimo ammissibile sugli snodi e terminali senza che si verifichino rotture o danneggiamento alle superfici di strisciamento. E' utilizzato nel caso in cui le sollecitazioni siano dovute a carichi ad urto. Per queste definizioni si è supposto un alloggiamento sufficientemente rigido tale da impedire deformazioni allo snodo stesso. Per i carichi dinamici bisogna precisare che essi riguardano soltanto il corretto funzionamento dello snodo inserito nel terminale; pertanto è corretto indicare a catalogo i valori dati dal costruttore degli snodi.

**PRESSIONE**

Un adeguato carico specifico è necessario per ottenere una durata d'esercizio sufficiente per la nostra applicazione.

La pressione specifica è un criterio di valutazione molto importante per la scelta dello snodo.

È determinabile conoscendo:

K = valore di carico specifico in  $\text{N/mm}^2$  ricavabile dalla tabella.

P = Carico equivalente in KN.

C = Coefficiente di carico dinamico in KN ricavabile dalla tabella dimensionale.

Accoppiamento di strisciamento	Indice specifico di carico K
Acciaio su Acciaio	K = 100 $\text{N/mm}^2$
Acciaio su Bronzo	K = 50 $\text{N/mm}^2$
Acciaio su PTFE	K = 100 $\text{N/mm}^2$
Acciaio su tessuto PTFE	K = 150 $\text{N/mm}^2$

$$p = K \cdot \frac{P}{C}$$

TABELLA DI CONVERSIONE		
UNITA' DI MISURA		
KiloNewton	kN	1
Newton	N	1000
Kilogrammo-forza	kgf	101,972
Tonnellata-forza	tnf	0,102

Il prodotto dato dalla pressione specifica per la velocità di strisciamento ha notevole influenza nel calcolo della durata.

**DURATA**  
Con il calcolo basato, su prove di laboratorio, esprimiamo la quantità di movimenti o di ore di funzionamento che la maggior parte di una determinata quantità di snodi raggiunge a parità di condizioni di funzionamento prima del determinarsi di danneggiamenti o rotture.

**FORMULE PER IL CALCOLO DELLA DURATA**

**Con lubrificazione unica.**  
a) Determinazione del carico dinamico equivalente P  
dove  $P = FR \cdot K_f$  (vedi formula carico assiale + radiale)

b) Determinazione del carico specifico p

$$p = K \cdot \frac{P}{C} \quad [N/mm^2]$$

c) Determinazione della velocità media di strisciamento

$$V = 2,91 \cdot 10^{-4} \cdot ds \cdot \beta_1 \cdot f \quad [mm/s]$$

Dove ds è il diametro della sfera in mm (vedi tabella dimensionale)  
 $\beta_1$  angolo di oscillazione in gradi  
f è la frequenza di oscillazione al minuto

d) Calcolo della durata L

$$L = 1,28 \cdot 10^7 \cdot f_1 \cdot \frac{V^{0.5} \beta_1^{0.2}}{f_2 \cdot ds^{0.64}} \cdot \frac{C}{P} \quad [\text{Oscillazioni}]$$

dove f1 fattore di direzione: carico unilaterale = 1 - Alternato = 2  
f2 fattore di carico per p = 1 ÷ 12.5 = 42  
per p = 12.5 ÷ 100 = p<sup>1.48</sup>

Formula valida per una temperatura ≤ 150°C

e) Calcolo della durata Lh, espressa in ore  $Lh = \frac{L}{f \cdot 60} \quad [\text{ore}]$

Nel caso fosse necessario stabilire la durata di snodi o terminali con lubrificazione saltuaria o esenti da manutenzione vi preghiamo di contattare il nostro servizio tecnico.

**CALCOLO DELLA DURATA DEI TERMINALI**

Per il calcolo della durata è indispensabile verificare il carico ammesso sul terminale, il calcolo della durata dei singoli snodi sferici e che il carico equivalente P sullo snodo non superi il carico P ammesso sul terminale.

Introduciamo fattori di riduzione nel calcolo nel caso in cui il carico è pulsante o alternato.

$$Pa = \frac{Co}{fr}$$

dove Pa è il carico ammesso sul terminale in KN  
Co Coefficiente di carico statico sul terminale in KN.  
fr Coefficiente del carico che per carico costante è uguale 1, mentre per carico pulsante o alternato è di 2.71

**LUBRIFICAZIONE E MANUTENZIONE**

Il lubrificante, ha il compito di ridurre l'attrito, proteggere dalla corrosione e separare efficacemente le superfici metalliche di strisciamento. La scelta esatta del tipo di lubrificante è fatta tenendo in considerazione il tipo di sollecitazione a cui è sottoposto lo snodo. Per un campo generale di applicazioni, raccomandiamo grassi comunemente in commercio, anticorrosione resistenti alla pressione, a base di sapone di litio con additivi lubrificanti solidi ed EP. E' buona norma una lubrificazione iniziale seguita da diverse fasi di rilubrificazione al fine di sostituire i residui del lubrificante usato permettendo così la eventuale fuoriuscita di impurità.

Gli snodi sferici esenti da manutenzione non devono essere lubrificati poiché si andrebbe ad impedire il trasferimento di particelle di PTFE dall'anello interno alla controsuperficie dell'anello esterno. Non è perciò previsto sia per gli snodi che per i terminali nessun sistema di rilubrificazione. Gli ingrassatori sono conformi alla normativa DIN 71412.

**TEMPERATURE DI FUNZIONAMENTO**

Tutti i terminali a snodo possono venire impiegati senza problemi in un campo di temperature che va dai - 0° C ai +100° C. A temperature più elevate si registrano riduzioni delle capacità di carico e comunque si consigliano analisi specifiche. Al di sotto di 0° C bisogna tener conto dell'infragilimento del materiale. Nella scelta dei terminali a snodo si deve anche considerare l'influenza della temperatura d'esercizio sui materiali costituenti lo snodo. Tutti gli snodi acciaio su acciaio possono venire impiegati senza problemi in un campo di temperature che va da - 50° ai + 180° C. Per gli snodi con accoppiamento acciaio su PTFE il campo di impiego è compreso fra i - 50° C e + 150° C. Per gli snodi con tenuta 2RS, che sono costituiti nella maggior parte dei casi da materiale poliuretano abbiamo un campo di impiego che va da - 20° C ai + 90° C.

**TOLLERANZE DI ACCOPIAMENTO RACCOMANDATE**

Al fine di non pregiudicare il buon funzionamento dello snodo sferico si consigliano le seguenti tolleranze di accoppiamento:

snodo sferico radiale con accoppiamento Acciaio su Acciaio	M7/m6 N7/m6	per alloggiamento in acciaio per alloggiamento in lega leggera
snodo sferico radiale con accoppiamento Acciaio su PTFE	K7/m6	per alloggiamento in acciaio per alloggiamento in lega leggera

**GARANZIA.** La garanzia della PAVARINI COMPONENTS S.p.A. per i vizi ed i difetti di qualsiasi natura ed entità ha la durata di un anno dalla data di consegna della merce, è limitata esclusivamente alla riparazione o alla sostituzione gratuita dei pezzi riconosciuti dalla PAVARINI COMPONENTS S.p.A. come difettosi, per difetti di materiale o deficienza di lavorazione. Il destinatario della merce deve denunciare i vizi ed i difetti apparenti entro otto giorni dal ricevimento dei beni e quelli occulti entro otto giorni dalla loro scoperta sotto pena di decadenza della garanzia. La merce contestata dovrà essere rispedita, franca di ogni spesa, alla Sede della PAVARINI COMPONENTS S.p.A. unitamente ad documento di accompagnamento riportante la qualità e la quantità della merce stessa, gli estremi della fattura originaria, ed i motivi della restituzione. La garanzia della PAVARINI COMPONENTS S.p.A. decade se i pezzi resi come difettosi sono stati comunque manomessi o riparati, e qualora i componenti non siano stati utilizzati o impiegati nel rispetto dei dati tecnici riportati nel catalogo tecnico della PAVARINI COMPONENTS S.p.A. Il reclamo non potrà mai dare luogo all'annullamento e/o alla riduzione delle ordinazioni da parte del committente, e tanto meno, alla corresponsione di indennizzi o risarcimenti di sorta da parte della PAVARINI COMPONENTS S.p.A.. La PAVARINI COMPONENTS S.p.A. non assume alcuna responsabilità per i danni derivati da accidenti di qualsiasi natura che si verificassero durante l'impiego dei suoi prodotti, siano questi dalla PAVARINI COMPONENTS S.p.A. riconosciuti difettosi o meno ad ancor quando la PAVARINI COMPONENTS S.p.A. ne avesse progettato l'applicazione.

**ROD END RANGE**

ROD	TYPE	PAGE
-----	------	------



**TS...C**

17

**DESIGN FEATURES** Hydraulic welding end for light application produced in accordance with regulation ISO 12240-4, series E, type S, rod having a central pivot on the bottom m of the connector welding at 45°, needs relubricating from Ø 25. The housing is made of S355JR UNI EN 10025 steel.

**FIELD OF APPLICATION** Rod end for range of links of cylinders, normally applied to the bottom of the hydraulic cylinder and the piston rod ends.

ROD	TYPE	PAGE
-----	------	------



**TS...N**

18

**DESIGN FEATURES** Hydraulic welding rod end, heavy application, connector to fix to the rectangular base and without central pivot. Needs lubricating from Ø 20. Equipped with bearing in accordance with regulation ISO 12240-1 SERIES E. The head is made of steel S355JR UNI EN 10025.

**FIELD OF APPLICATION** Rod end for heavy application to be welded to the bottom of the hydraulic cylinders. Removable bearing.

ROD	TYPE	PAGE
-----	------	------



**TS...CE-N**

19

**DESIGN FEATURES** Hydraulic welding rod end with similar characteristics to the TS...N type, differing in the bearing. In fact this end was produced in accordance with CETOP - ISDO 12240-1 series W (like the TAPR...CE type). Needs lubricating from Ø 20. Head produced in S355JR UNI EN 10025, with central joint.

**FIELD OF APPLICATION** For hydraulic cylinders produced in accordance with CETOP and DIN 24333, DIN 24336 and ISO 6020/1, ISO 6022. With grease-nipple.

ROD	TYPE	PAGE
-----	------	------

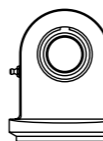

**TS...NF**

20

**DESIGN FEATURES:** Hydraulic rod end in steel S355JR UNI EN 10025 with cylinder button to be welded directly on the cylinder reed. It features a circular base without central pivot. A bearing in accordance with standard ISO 12240-1 E series is fixed to the head by means of rings. A grease nipple is provided for lubrication.

**FIELD OF APPLICATION:** Heavy-duty rod end to be welded to the reed of the hydraulic cylinders. Dismountable bearing.

ROD	TYPE	PAGE
-----	------	------

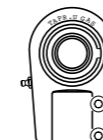

**TAPR...U GAS**

21

**DESIGN FEATURES** Rod end for hydraulics in steel C45 with internal thread in solid execution-long thread, which has a larger wheel-base compared to the types TAPR..U and TAPR..N. Body in steel C45 forging up to dimension 60; from dimension 70 on, the body is made of spheroidal cast iron. It has a ball joint found to conform to the requirements of ISO 12240-1, series E, fixed inside the head through elastic rings. Complete with lubricator with Gas thread for lubrication. The shank is slivered so to create a sprang anchor thread through two hexagonal screws fixed to conform to the requirements of DIN 912.

**FIELD OF APPLICATION** Rod end with a particular shape for hydraulic cylinders. The strong structure allows maximum wheel-bases of hitching with a maximum exploitation of the stroke.

**ROD END RANGE**

ROD	TYPE	PAGE
	TFI ... FKB ...T-2RS	29
	...T-2RS MAGGIORATO	29
	TFE... MKB ...T-2RS	30
	...T-2RS MAGGIORATO	30
	TFI ... UB	31

**DESIGN FEATURES** Regulation ISO 12240-4 seies E type M ends like above but maintenance free. The internal bearing has an inside ring made by steel with PTFE.

**FIELD OF APPLICATION** Ideal for use with constant uniform loads and slow movements for swinging corners.

**AGRICULTURAL BALL JOINT TERMINAL**

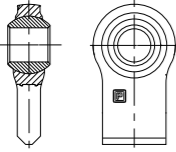
AGRICULTURAL BALL JOINT TERMINAL	TYPE	PAGE
	SR...	32-37

**SWINGING ENDS, FEMALES WELD BOSS FORKS, PIN AND SEAL RINGS (SEEGER)**

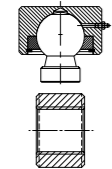
SWINGING ENDS, FEMALES WELD BOSS	TYPE	PAGE
	BO...	38
	BS...	39

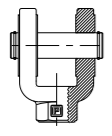
FORK	TYPE	PAGE
	KLP...	40

PIN	TYPE	PAGE
	PIN KP...	40

FORK	TYPE	PAGE
	FF... THREADED FORKS / FS... WELDING FORKS	41

SEAL RING (SEEGER)	TYPE	PAGE
	I...SB / I...DIN / E...DIN	42

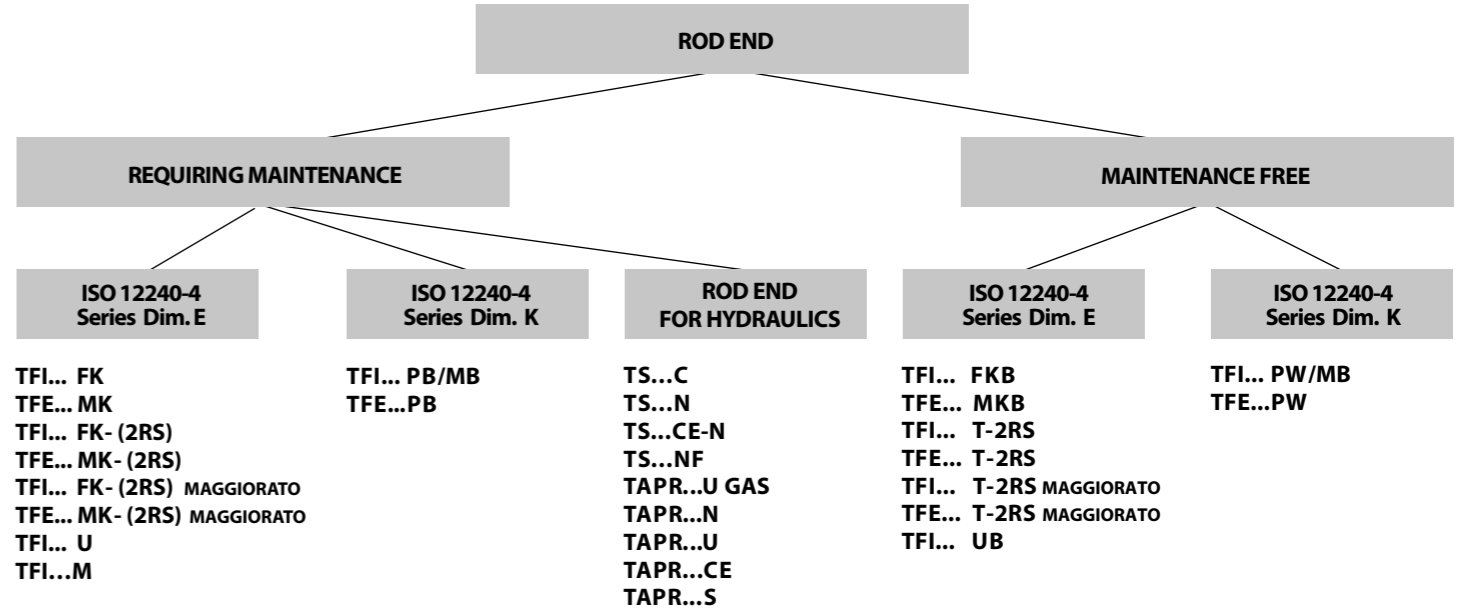

**ROD ENDS**

The ends consist of a body in which a standard bearing is housed. They can be supplied with an external or internal thread, right or left handed, with welded extremities. They are standard products, the steel on steel versions needing lubrication; steel on bronze with PTFE, and steel on PTFE material not requiring maintenance. Choice of type, as with the bearings, depends essentially on the use for which it is destined. As far as construction characteristics of the various types of ends are concerned we refer you to the previous tables. The most important series in our range is represented by ends for hydraulic applications, we can divide these into two group:

- Hydraulic rod ends internally threaded
- Hydraulic rod ends with welded ends

Considering the field of application, these ends are usually supplied in series, with steel on steel surfaces, where we find situations of alternate loads. These are ends produced and constructed especially for these applications, as in the case of connecting rods and hydraulic cylinders where maximum security of anchorage is required. The TAPR..CE series represents the best possible fixing factor, infact we equipped the connector, having an internal thread, with a longitudinal cut so as to permit optimum fixing on the thread by way of two locking hexagon socket screws.

**SELECTION GUIDE**

Multiple conditions of use for bearings and ends determine their different construction characteristics and choice of materials. Every one of our products has therefore been planned and produced to satisfy the various application needs. There are numerous factors which influence the choice of bearing or end and all must be considered with great attention, which is why it is not possible to determine a general view and why we should take them, one at a time, for further analysis. However there are some fundamental elements to take into consideration in this choice, ie:

**- LOAD MAINTENANCE WORKING TEMPERATURE TILTING ANGLE LOAD**

To determine type, dimension and materials for working surfaces of a bearing or end, it is fundamentally important to understand the extent and direction of the load as well as the way in which it functions.  
 Radial Load - All the spherical plain bearings are able to support high radial loads and, within certain limits, axial loads, in both directions which move simultaneously.  
 Loads Which Move In One Direction - A situation in which the load always moves in one direction in the same way, and in this case, the area of the load is always on the same side as the bearing. For applications where the bearing is subject to static stress or may be subject to very small movements under load (but comparable to almost static stress). The use of plain bearings is recommended or ends with surfaces steel on steel. On the other hand when a bearing is subject to dynamic stress, spherical bearings ok maintenance free ends are recommended.  
 Loads Moving In Alternate Directions - In this case we recommend the use of spherical bearings or ends with surface steel on steel, use of spherical bearings or maintenance free bearings is foreseen only within certain limits.

- THE GIVEN **LOAD FACTOR** REFERS ONLY TO ROD END ASSEMBLED WITH "PAVARINI" SPHERICAL PLAIN BEARING "LSP" BRAND

**MAINTENANCE**

With regard to field of application, bearings requiring maintenance, maintenance free or lubrication type ends may be required. In the first case, bearings are constructed using particular types of materials for their grooved surfaces so as to render lubrication superfluous, permitting a maintenance free exercise. In the second case, bearings with surface steel on steel have to be relubricated at regular intervals to guarantee correct and lasting performance.

**TILT ANGLE**

The admissible angle of tilt varies in function with the dimensional series, the execution and dimensions of the bearings. They are always indicated in the relevant tables.

**CALCULATION OF DURATION AND SIZING**

To work correctly in the choice and sizing of the bearing, various factors must be taken into consideration and categories to consider are:

**- LOAD MOVEMENT DURATION LUBRICATION**

Others elements, which are difficult to evaluate, effect the selection and relative duration. Loads and impact, working environment and cleanliness are not in fact taken account of in the analytical calculation. Knowledge of the intensity and direction of the loads is indispensable. For the calculation of the technical duration we consider that load (F) coincides the value of load of duration P, when the force moves in a purely radial direction and the size and direction do not vary during the operation F=P=FR (see drawing).

SISTEMA QUALITÀ CERTIFICATO

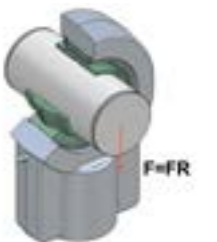

In the case of stress being, at the same time, axial and radial, a value of calculation P must be introduced in the calculation of duration that takes account of the influence of the combined moving forces. (see drawing).

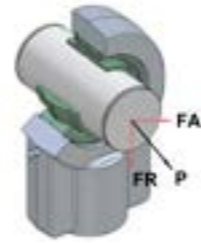

We calculate the value P with the formula.  
 $P = K_f \cdot FR$   
 Where:  
 P = Dynamic load equivalent in KN  
 FR = Radial load in KN  
 FA = Axial load in KN  
 Kf = Correction coefficient that in this case is obtained by the formula:  

$$K_f = 0,978 \cdot 21,546^{\frac{FA}{FR}}$$

**MOVEMENT AND FREQUENCY**

The presence of movement and its frequency characterize the dynamic condition of the operation (see drawings).

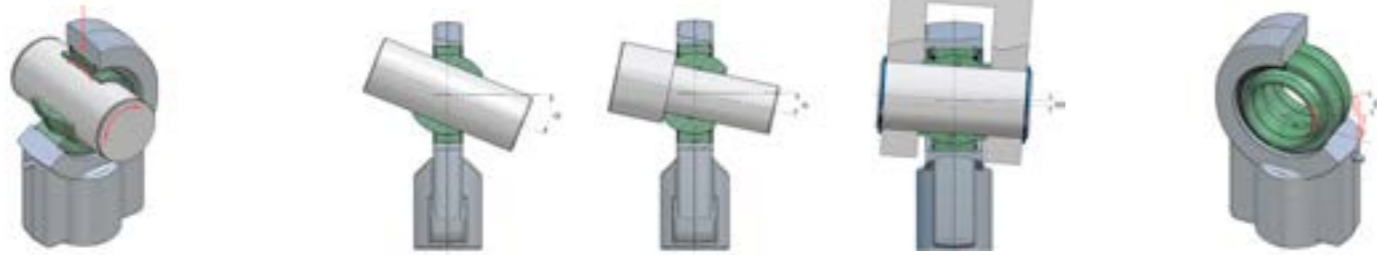

From the drawings it is possible to identify three types of movement expressed in the following categories:  
 - Angle of oscillation  $\beta$   
 - Angle of tilt  $\alpha$   
 - Angle of movement  $\beta_1$  in the case of combined movements of oscillation and tilt.

The following calculation is needed  $\beta_1 = \sqrt{\beta^2 + \alpha^2}$

**FREQUENCY**

The number of movements is expressed in units of time and dimensionally is expressed in  $\text{min}^{-1}$ . It is introduced in the calculation function without periodical arrests.

**LOAD COEFFICIENT**

The coefficient of dynamic load C is used to calculate duration when we are in the presence of a dynamic type of stress, that is when during loading there are oscillating tilt movements or rotating movements.

For use in this category it is indispensable for the load to move in a radial direction. Dynamic applications represent the maximum permissible load and exploiting it completely does not allow a long duration. The relationship C/P is usually found in a range 1 - 5 inclusive and never less than 1.

The coefficient of static load Co represents the maximum permissible static load on the bearings and ends before breakage or damage occurs to the grooved surfaces, used in cases of stress due to shock loads. For these definitions, a sufficiently rigid housing is assumed to exist so as to prevent deforming the bearing itself.

**PRESSURE**

An adequate specific load is necessary to obtain a duration of exercise sufficient for our use. The specific pressure is a criterion of evaluation which is very important to the choice of bearing it is determinable knowing that:

K = Value of specific load in N/mm<sup>2</sup> shown in the table.  
 P = Load equivalent in KN  
 C = Coefficient of dynamic load in KN available in the dimension table.

Sliding contact surfaces	Contact pressure parameter K
Steel/Steel	K = 100 N/mm <sup>2</sup>
Steel/Bronze	K = 50 N/mm <sup>2</sup>
Steel/PTFE foil	K = 100 N/mm <sup>2</sup>
Steel/PTFE fabric	K = 150 N/mm <sup>2</sup>

$$p = K \cdot \frac{P}{C}$$

The product of the specific pressure times the speed of drag has a notable affect on the calculation of duration.

**DURATION**

Using the calculation, based on laboratory tests, we can express the quantity of movements or the hours of operation that the greater part of a determinate number of bearings arrives at equal to the operating conditions, before damage or breakage.

**FORMULAS FOR THE CALCULATION OF DURATION**

**With Single Lubrication.**

a) Determination of dynamic load equal to P  
 Where  $P = FR \cdot K_f$  (see formula)

b) Determination of dynamic load equal p

$$p = K \cdot \frac{P}{C} \quad [\text{N/mm}^2]$$

c) Determination of average dragging speed.

$$V = 2,91 \cdot 10^{-4} \cdot ds \cdot \beta_1 \cdot f \quad [\text{mm/s}]$$

Where ds is the diameter of the sphere (see dimension table)  
 $\beta_1$  Angle of oscillation in degree  
 f Is the frequency of oscillation in turns.

d) Calculation of duration L

$$L = 1,28 \cdot 10^7 \cdot f_1 \cdot \frac{v^{0,5} \beta_1^{0,2}}{f_2 \cdot ds^{0,64}} \cdot \frac{C}{P} \quad [\text{Oscillations}]$$

Where f1 Load direction factor In one direction=1 - Alternate = 2  
 f2 Load factor for p = 1 ÷ 12.5 = 42  
 per p = 12.5 ÷ 100 = p<sup>1,48</sup>

Formula valid for temperatures ≤ 150°

e) Formula Lh [hour]  $Lh = \frac{L}{f \cdot 60} \quad [h]$

In case of it being necessary to establish the duration of bearings or ends with occasional lubrication or maintenance free we would ask you to contact our service technical department.

**CALCULATION OF LIFE OF THE ENDS**

To calculate this duration we must check the load given to the bearings, the calculation of the duration of each single bearing and the load equivalent to P on the bearing does not go above the load P given to the end.

We shall introduce reduction factors in the case of the load being pulsating or alternate.

$$Pa = \frac{Co}{fr}$$

Where: Pa is the load given to the end in KN  
 Co Coefficient of static load on end in KN  
 fr Coefficient of load that for constant load is equal to 1, while for a pulsating or alternating load it is 2.71.

**LUBRICATION AND MAINTENANCE**

The lubricant, grease or oil, has the purpose of separating the dragging metallic surfaces, to protect against corrosion and to reduce friction. The exact choice of lubricant is made taking the type of stress the bearing will be subject to into consideration.

For a fairly vast field of application, we recommend anti-corrosion lubricant, resistant to pressure, with a soap base with solid lubricant additives and EP.

It is a good rule to carry out an initial lubrication followed by various phases of relubrication and at the end to substitute the residue of the lubricant which has been used and allow the flushing out of impurities. We do not need to lubricate the maintenance free bearings because it would impede the transfer of PTFE particles from the internal ring to the counter surface of the external ring. So therefore no lubrication system is planned for the bearings or the ends. For our ends the following lubrication systems are planned.

The grease nipples are according standard DIN 71412.

**WORKING TEMPERATURE**

Another important element having effect on the component materials of the bearing and ends is the temperature. All the rod ends can be used without problems in a temperature ranging from 0° C to +100° C. In higher temperatures reductions in load capacity are registered and we advise specific analysis. Under 0° C must take account of embrittlement of the material. For the choice of rod ends is also important the influence of temperature on the bearing. For the bearings with steel /steel the field to use is between -50° C to +180° C. For the bearings steel on PTFE the operating field is between -50° C to +180° C. For the bearings with -2RS (constituted for the large part of poliurate materials) the operational field is between -20° C to +90° C.

**BEARING TOLERANCES RECOMMENDED**

So as not to prejudice the proper functioning of the bearing we recommend the following tolerances:

Radial Bearings Steel/Steel	M7/m6 For Steel Housing N7/m6 For Light Metal Housing
Radial Bearings Steel/PTFE	K7/m6 For Steel Housing PTFE For Light Metal Housing

**WARRANTY.** The warranty of PAVARINI COMPONENTS S.p.A. for defects and faults of any nature and entity has a duration of one year from the date of delivery of the goods and is exclusively limited to the repair or replacement—free of charge—of parts which are acknowledged as defective by PAVARINI COMPONENTS S.p.A. due to defects in materials or manufacturing. The recipient of the goods must report the defects and faults within eight days from the date of receipt of the goods under penalty of voidance of the guarantee.

The disputed goods must be returned, free from any accessory charges, to the registered offices of PAVARINI COMPONENTS in conjunction with the delivery note specifying the quality and quantity of the goods themselves as well as the details of the invoice and the reasons for the return. The guarantee of PAVARINI COMPONENTS S.p.A. ceases to be effective if the returned pieces were tampered with or repaired or if the components were not utilized in compliance with the specifications stated in the technical catalogue of PAVARINI COMPONENTS S.p.A. The complaint may never result in the cancellation and/or reduction of the orders of the customer nor may result in compensation or indemnities of any type for PAVARINI COMPONENTS S.p.A.

PAVARINI COMPONENTS S.p.A. is not liable for any damages derived from the accidents of any nature which occur during the usage of its products, regardless of whether these products were acknowledged as defective or not by PAVARINI COMPONENTS S.p.A. after their application was designed.



**TS...C**  
**(SC...ES; GK...DO)**

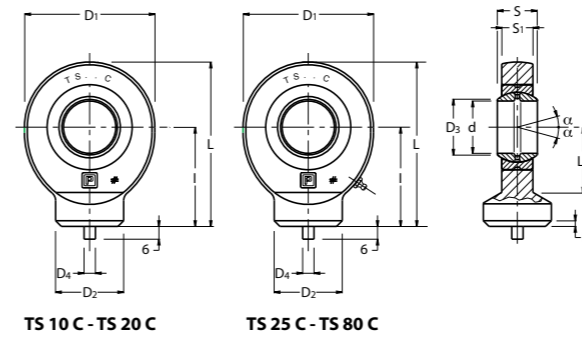

TERMINALI A SNODO

SNODO SFERICO ISO 12240-4, SERIE E-TIPO S  
RILUBRIFICABILI  
ACCOPPIAMENTO ACCIAIO SU ACCIAIO

ROD ENDS

SPHERICAL BEARING ISO 12240-4, SERIES E-TYPE S  
WITH GREASE NIPPLE  
COUPLING: STEEL/STEEL



<b>pavarini</b> COMPONENTS	<b>SKF</b>	<b>INA</b>
<b>TS...C</b>	SC...ES	GK...DO
<b>TS...N</b>	SCF...ES	GF...DO
<b>TS...CE-N</b>	-	-
<b>TS...NF</b>	-	-
<b>TAPR...N</b>	-	-
<b>TAPR...U</b>	SIR...ES	GIHRK...DO
<b>TAPR...U GAS</b>	-	-
<b>TAPR...CE</b>	SIQG...ES	GIHNRK...LO
<b>TAPR...S</b>	SIJ...ES	-
<b>TFI...U/UB</b>	-	-
<b>TFI...FK /...FK-2RS</b>	SI...E (6÷12) - SI...ES (15÷30) - SIA...ES-2RS (35÷80)	GIR...DO/GIR...DO-2RS
<b>TFI... FK MAGG./...FK-2RS MAGG.</b>	SI...ES (1) - SI...ES - 2RS (1)	-
<b>TFI...M</b>	SI...ES-2RS	-
<b>TFE... MK/...MK-2RS</b>	SA...E (6÷12) - SA...ES (15÷30) - SAA...ES-2RS (35÷80)	GAR...DO/GAR...DO-2RS
<b>TFE... MK MAGG./...MK-2RS MAGG.</b>	SA...ES-2RS (1)	-
<b>TFI... FKB/...T-2RS</b>	SI...C - SIA... - TXE-2LS	GIR...UK/GIR...UK-2RS
<b>TFI... T-2RS MAGG.</b>	SI...TXE-2LS (1)	-
<b>TFE... MKB/... T-2RS</b>	SA...C - SAA...TXE-2LS	GAR...UK/GAR...UK-2RS
<b>TFE... T-2RS MAGG.</b>	SA...TXE-2LS (1)	-

(1) CON DIFFERENTI DIMENSIONI (VEDI CATALOGO)  
(1) WITH DIFFERENT DIMENSIONS (SEE CATALOGUE)

(... = Ø FORO)  
(... = Ø INNER HOLE)

SIGLA (*) ARTICLE (*)	d	TOLLERANZE TOLERANCES		S	D3	I	D1	D2	S1	L	L1	L2	D4	FATTORI DI CARICO LIMITE LOAD FACTORS		GIUOCO SNODO RADIALE RADIAL CLEARANCE	ANGOLO DI OSCILLAZIONE α SWINGING ANGLE α	PESO IN Kg WEIGHT Kg
		d	S											C	Co			
mm.															KN	mm	α°	
<b>TS 10 C (1)</b>	10	0 ± -0.008	0 ± -0.12	9	13.2	24	29	15	7	38.5	15	1.5	3	8.15	15.6	0.032 - 0.068	12	0.04
<b>TS 12 C (1)</b>	12	0 ± -0.008	0 ± -0.12	10	15	27	34	17.5	8	44	18	1.5	3	10.8	21.6	0.032 - 0.068	11	0.06
<b>TS 15 C (2)</b>	15	0 ± -0.008	0 ± -0.12	12	18.4	31	40	21	10	51	20	2	4	17	32	0.040 - 0.082	8	0.12
<b>TS 16 C (2) (A)</b>	16	0 ± -0.008	0 ± -0.12	14	20.7	35	46	24	11	58	23	2	4	19	36	0.040 - 0.082	9	0.17
<b>TS 17 C (2)</b>	17	0 ± -0.008	0 ± -0.12	14	20.7	35	46	24	11	58	23	2	4	21.2	40	0.040 - 0.082	10	0.18
<b>TS 20 C (2)</b>	20	0 ± -0.008	0 ± -0.12	16	24.1	38	53	27.5	13	64.5	27.5	2	4	30	54	0.040 - 0.082	9	0.26
<b>TS 25 C</b>	25	0 ± -0.010	0 ± -0.12	20	29.3	45	64	33.5	17	77	33	3	4	48	72	0.050 - 0.100	7	0.45
<b>TS 30 C</b>	30	0 ± -0.010	0 ± -0.12	22	34.2	51	73	40	19	87.5	37.5	3	4	62	95	0.050 - 0.100	6	0.67
<b>TS 35 C</b>	35	0 ± -0.010	0 ± -0.12	25	39.7	61	82	47	21	102	43	3	4	80	125	0.050 - 0.100	6	1.02
<b>TS 40 C</b>	40	0 ± -0.012	0 ± -0.12	28	45	69	92	52	23	115	48	4	4	100	156	0.060 - 0.120	7	1.40
<b>TS 45 C</b>	45	0 ± -0.012	0 ± -0.12	32	50.7	77	102	58	27	128	52	4	6	127	208	0.060 - 0.120	7	1.93
<b>TS 50 C</b>	50	0 ± -0.012	0 ± -0.12	35	56	88	112	62	30	144	59	4	6	156	250	0.060 - 0.120	6	2.69
<b>TS 60 C</b>	60	0 ± -0.012	0 ± -0.15	44	66.8	100	135	70	38	167.5	72.5	4	6	245	390	0.060 - 0.120	6	4.60
<b>TS 70 C</b>	70	0 ± -0.015	0 ± -0.15	49	77.8	115	160	80	42	195	86	5	6	315	510	0.072 - 0.142	6	7.00
<b>TS 80 C</b>	80	0 ± -0.015	0 ± -0.15	55	89.4	141	180	95	47	231	98	5	6	400	620	0.072 - 0.142	6	11.00

(1) NON RILUBRIFICABILE. (2) RILUBRIFICABILE MEDIANTE UN FORO DI LUBRIFICAZIONE SULLA TESTA Ø 2,5.

(\*) FORNIBILI ANCHE NELLA VERSIONE CON SNODO SFERICO RADIALE CON TENUTA (...-2RS), CON SNODO SFERICO SRC... OPPURE SRL... DISPONIBILITA'E PREZZO A RICHIESTA.

**E' POSSIBILE LA FORNITURA DI TERMINALI SPECIALI DOTATI DI SNODO SFERICO ESENTE DA MANUTENZIONE.**

**(VEDI CATALOGO SNODI SFERICI SERIE: SRB..., SRT...-2RS, SRLB..., SRLT...-2RS, SR...TGR, SR...TG3A...-2RS). PERTANTO I PEZZI SARANNO PRIVI DI INGRASSATORE O FORO OLIIATORE.**

(1) NON LUBRICATABLE. (2) LUBRICATABLE BY A LUBRICATION OPENING ON THE HEAD Ø 2,5.

(\*) ALSO SUPPLIABLE IN THE SPHERICAL BALL JOINT VERSION WITH 2RS, WITH SPHERICAL BEARING SRC... AND SRL... AVAILABILITY AND PRICES UPON REQUEST.

**POSSIBLE TO SUPPLY SPECIAL ROD ENDS WITH MAINTANANCE FREE SPHERICAL BEARING.**

**(SEE THE SPHERICAL BEARINGS FOR SERIES: SRB..., SRT...-2RS, SRLB..., SRLT...-2RS, SR...TGR, SR...TG3A...-2RS). THESE ARTICLES ARE AVAILABLE WITHOUT GREASE NIPPLES OR LUBRICATION HOLES.**

**(A) FUORI NORMATIVA - OUT OF STANDARD**

TUTTI I TERMINALI POSSONO ESSERE PRODOTTI SU RICHIESTA IN ACCIAIO INOSSIDABILE. ALCUNE DIMENSIONI POSSONO DIFFERIRE DAL CATALOGO.

ALL ROD ENDS CAN BE MADE OF STAINLESS STEEL. WE INFORM THAT SOME DIMENSIONS MIGHT BE DIFFERENT, FROM THE DIMENSIONS IN THE CATALOGUE

**TS...N**  
(SCF...ES; GF...DO)

TERMINALI A SNODO

SNODO SFERICO ISO 12240-1 SERIE E  
RILUBRIFICABILI

ACCOPPIAMENTO ACCIAIO SU ACCIAIO

ROD ENDS

SPHERICAL BEARING ISO 12240-1 SERIES E  
WITH GREASE NIPPLE

COUPLING: STEEL/STEEL

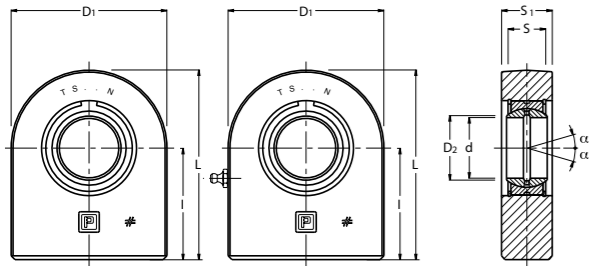

TS 15 N TS 16 N - TS-120 N



**TS...CE-N**  
(GF...LO)

TERMINALI A SNODO

SNODO SFERICO ISO 12240-1 SERIE W  
RILUBRIFICABILI  
ACCOPPIAMENTO: ACCIAIO SU ACCIAIO

ROD ENDS

SPHERICAL BEARING ISO 12240-1 SERIES W  
WITH GREASE NIPPLE  
COUPLING: STEEL/STEEL

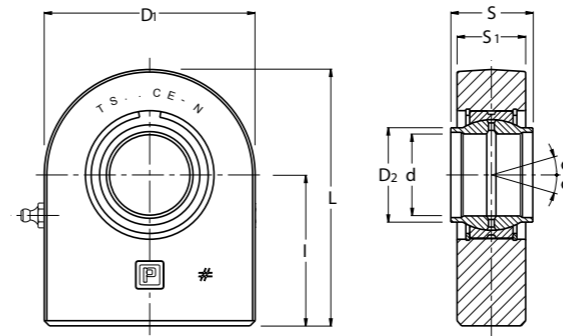

SIGLA (*) ARTICLE (*)	d	TOLLERANZE TOLERANCES		S	D2	I	D1	S1	L	FATTORI DI CARICO LIMITE LOAD FACTORS			GIUOCO SNODO RADIALE RADIAL CLEARANCE	ANGOLO DI OSCILLAZIONE CC SWINGING ANGLE CC α°	PESO IN Kg. WEIGHT Kg.
		d	s							Dinamico C	Statico Co	Co			
		mm.								KN		mm			
TS 15 N (2)	15	0 + -0.008	0 + -0.12	12	18.4	31	45	16	53.5	17	53	0.040 - 0.082	8	0.22	
TS 16 N (A)	16	0 + -0.008	0 + -0.12	14	20.7	35	48	17.5	59	21.2	59	0.040 - 0.082	10	0.29	
TS 17 N	17	0 + -0.008	0 + -0.12	14	20.7	35	48	17.5	59	21.2	65	0.040 - 0.082	10	0.29	
TS 20 N	20	0 + -0.010	0 + -0.12	16	24.1	38	50	19	63	30	67	0.040 - 0.082	9	0.36	
TS 25 N	25	0 + -0.010	0 + -0.12	20	29.3	45	55	23	72.5	48	69.5	0.050 - 0.100	7	0.53	
TS 30 N	30	0 + -0.010	0 + -0.12	22	34.2	51	65	28	83.5	62	118	0.050 - 0.100	6	0.85	
TS 35 N	35	0 + -0.012	0 + -0.12	25	39.7	61	83	30	102.5	80	196	0.050 - 0.100	6	1.50	
TS 40 N	40	0 + -0.012	0 + -0.12	28	45	69	100	35	119	100	305	0.060 - 0.120	7	2.42	
TS 45 N	45	0 + -0.012	0 + -0.12	32	50.7	77	110	40	132	127	386	0.060 - 0.120	7	3.39	
TS 50 N	50	0 + -0.012	0 + -0.12	35	56	88	123	40	149.5	156	441	0.060 - 0.120	6	4.24	
TS 60 N	60	0 + -0.015	0 + -0.15	44	66.8	100	140	50	170	245	570	0.060 - 0.120	6	7.10	
TS 70 N	70	0 + -0.015	0 + -0.15	49	77.8	115	164	55	197	315	724	0.072 - 0.142	6	10.70	
TS 80 N	80	0 + -0.015	0 + -0.15	55	89.4	141	180	60	231	400	804	0.072 - 0.142	6	15.10	
TS 90 N (1)	90	0 + -0.020	0 + -0.20	60	98.1	150	226	65	263	490	1340	0.072 - 0.142	5	23.40	
TS 100 N (1)	100	0 + -0.020	0 + -0.20	70	109.5	170	250	70	295	610	1516	0.085 - 0.165	7	33.10	
TS 110 N (1)	110	0 + -0.020	0 + -0.20	70	121.2	185	295	80	332.5	655	2340	0.085 - 0.165	6	48.50	
TS 120 N (1)	120	0 + -0.020	0 + -0.20	85	135.5	210	360	90	390	950	3210	0.085 - 0.165	6	79.50	

SIGLA (*) ARTICLE (*)	d	TOLLERANZE TOLERANCES		S	D2	I	D1	S1	L	FATTORI DI CARICO LIMITE LOAD FACTORS			GIUOCO SNODO RADIALE RADIAL CLEARANCE	ANGOLO DI OSCILLAZIONE CC SWINGING ANGLE CC α°	PESO IN Kg. WEIGHT Kg.
		d	s							Dinamico C	Statico Co	Co			
		mm.								KN		mm.			
TS 20 CE-N	20	0 + +0.021	0 + -0.21	20	25	38	50	19	63	30	74	0.040 - 0.082	4	0.36	
TS 25 CE-N	25	0 + +0.021	0 + -0.21	25	30.5	45	55	23	72.5	48	95	0.050 - 0.100	4	0.54	
TS 32 CE-N	32	0 + +0.025	0 + -0.25	32	38	65	70	27	100	62.5	168	0.052 - 0.100	4	1.12	
TS 40 CE-N	40	0 + +0.025	0 + -0.25	40	46	69	100	35	119	100	268	0.060 - 0.120	4	2.50	
TS 50 CE-N	50	0 + +0.025	0 + -0.25	50	57	88	123	40	149.5	156	362	0.060 - 0.120	4	4.60	
TS 63 CE-N	63	0 + +0.030	0 + -0.30	63	71.5	107	145	50	178	248	570	0.072 - 0.142	4	9.30	
TS 70 CE-N	70	0 + +0.030	0 + -0.30	70	79	115	164	55	197	315	800	0.072 - 0.142	4	11.25	
TS 80 CE-N	80	0 + +0.030	0 + -0.30	80	91	141	180	60	231	400	874	0.072 - 0.142	4	15.75	
TS 90 CE-N(1)	90	0 + +0.035	0 + -0.35	90	99	150	226	65	263	490	1045	0.072 - 0.165	4	24.00	
TS 100 CE-N(1)	100	0 + +0.035	0 + -0.35	100	113	170	250	70	295	610	1330	0.085 - 0.165	4	33.95	
TS 110 CE-N(1)	110	0 + +0.035	0 + -0.35	110	124	185	295	80	332.5	655	1490	0.085 - 0.165	4	49.00	
TS 125 CE-N(1)	125	0 + +0.040	0 + -0.40	125	138	210	360	90	390	950	2200	0.085 - 0.165	4	81.00	

(1) PANTOGRAFATI  
(2) SU RICHIESTA TS160CEN - TS200CEN

(1) PROFILE PLATE  
(2) ON REQUEST TS160CEN - TS200CEN

TUTTI I TERMINALI POSSONO ESSERE PRODOTTI SU RICHIESTA IN ACCIAIO INOSSIDABILE. ALCUNE DIMENSIONI POSSONO DIFFERIRE DAL CATALOGO.  
ALL ROD ENDS CAN BE MADE OF STAINLESS STEEL. WE INFORM THAT SOME DIMENSIONS MIGHT BE DIFFERENT, FROM THE DIMENSIONS IN THE CATALOGUE

(\*) FORNIBILI ANCHE NELLA VERSIONE CON SNODO SFERICO RADIALE CON TENUTA - (...-2RS), CON SNODO SFERICO SRC... OPPURE SRL... . DISPONIBILITA'E PREZZO A RICHIESTA.

(1) PANTOGRAFATI.  
(2) RILUBRIFICABILE MEDIANTE UN FORO DI LUBRIFICAZIONE SULLA TESTA.  
SU RICHIESTA TS160N - TS200N

E' POSSIBILE LA FORNITURA DI TERMINALI SPECIALI DOTATI DI SNODO SFERICO ESENTE DA MANUTENZIONE.  
(VEDI SNODI SFERICI SERIE: SRB..., SRT...-2RS, SRLB..., SRLT...-2RS, SR...TGR, SR...TG3A...-2RS). PERTANTO I PEZZI SARANNO PRIVI DI INGRASSATORE O FORO OLIIATORE.

(\*) ALSO SUPPLIABLE IN THE SPHERICAL BALL JOINT VERSION WITH 2RS, WITH SPHERICAL BEARING SRC... AND, SRL... . AVAILABILITY AND PRICES UPON REQUEST.

(1) PROFILE PLATE.  
(2) LUBRICATABLE BY A LUBRICATION OPENING ON THE HEAD.  
ON REQUEST TS160N - TS200N

POSSIBLE TO SUPPLY SPECIAL ROD ENDS WITH MAINTANANCE FREE SPHERICAL BEARING.  
(SEE THE SPHERICAL BEARINGS FOR SERIES : SRB, SRT...-2RS, SRLB, SRLT...-2RS, SR...TGR, SR...TG3A...-2RS). THESE ARTICLES ARE AVAILABLE WITHOUT GREASE NIPPLES OR LUBRICATION HOLES.

(A) FUORI NORMATIVA - OUT OF STANDARD

TUTTI I TERMINALI POSSONO ESSERE PRODOTTI SU RICHIESTA IN ACCIAIO INOSSIDABILE. ALCUNE DIMENSIONI POSSONO DIFFERIRE DAL CATALOGO.  
ALL ROD ENDS CAN BE MADE OF STAINLESS STEEL. WE INFORM THAT SOME DIMENSIONS MIGHT BE DIFFERENT, FROM THE DIMENSIONS IN THE CATALOGUE

**TS...NF**

TERMINALI A SNODO CON FONDELLO  
SNODO SFERICO ISO 12240-1 SERIE E  
RILUBRIFICABILI  
ACCOPPIAMENTO ACCIAIO SU ACCIAIO

ROD ENDS WITH BULKHEAD  
SPHERICAL BEARING ISO 12240-1 SERIES E  
WITH GREASE NIPPLE  
COUPLING: STEEL/STEEL

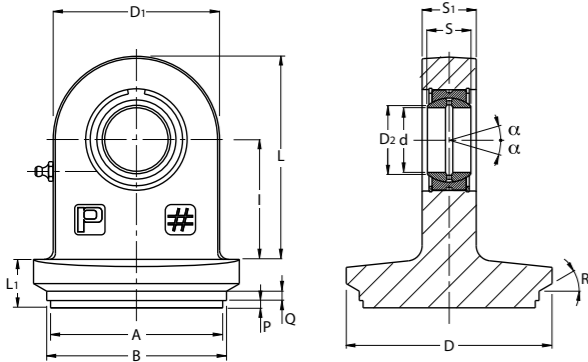

SIGLA ARTICLE	d	d	s	S	D2	I	D1	S1	L	L1 max	D max	FATTORI DI CARICO LIMITE LOAD FACTORS		GIUOCO SNODO RADIALE RADIAL CLEARANCE	ANGOLO DI OSCILLAZIONE C <sub>α</sub> SWINGING ANGLE C <sub>α</sub> GRADI RATES
												C Dinamico Dynamic	C <sub>0</sub> Statico Static		
TS20NF	20	0+-0.010	0+-0.12	16	24.1	38	50	19	63	13	60	30	67	0.030±0.082	9
TS25NF	25	0+-0.010	0+-0.12	20	29.3	45	55	23	72.5	14	73	48	69.5	0.037±0.100	7
TS30NF	30	0+-0.010	0+-0.12	22	34.2	51	65	28	83.5	15	95	62	118	0.037±0.100	6
TS35NF	35	0+-0.012	0+-0.12	25	39.7	61	83	30	102.5	15	105	80	196	0.037±0.100	6
TS40NF (1)	40	0+-0.012	0+-0.12	28	45	69	100	35	119	16	115	100	305	0.043±0.120	7
TS50NF (1)	50	0+-0.012	0+-0.12	35	56	88	123	40	149.5	19	145	156	441	0.043±0.120	6
TS60NF (1)	60	0+-0.015	0+-0.15	44	66.8	100	140	50	170	21	170	245	570	0.043±0.120	6

(1) DISPONIBILI SU RICHIESTA.  
IN FASE D'ORDINE IL CLIENTE DOVRA' FORNIRE I VALORI DELLE QUOTE L1, D, A, B, P, Q, R  
I VALORI D MAX E L1 MAX INDICATI NELLA TABELLA INDICANO IL DIAMETRO MASSIMO E LO SPESSORE MASSIMO DEL FONDELLO FORNIBILI  
(\* ) FORNIBILI ANCHE NELLA VERSIONE CON SNODO SFERICO RADIALE CON TENUTA 2RS, CON SNODO SRC... OPPURE SRL... . DISPONIBILITA' E PREZZO A RICHIESTA  
**E' POSSIBILE LA FORNITURA DI TERMINALI SPECIALI DOTATI DI SNODO SFERICO ESENTE DA MANUTENZIONE.**  
**(VEDI CATALOGO SNODI SFERICI SERIE: SRB..., SRT...-2RS, SRLB..., SRLT...-2RS, SR...TGR, SR...TG3A...-2RS).**  
**PERTANTO I PEZZI SARANNO PRIVI DI INGRASSATORE O FORO OLIAITORE.**

(1) AVAILABLE ONLY ON REQUEST.  
L1, D, A, B, P, Q, R DIMENSIONS MUST BE ADVISED WHEN THE ORDER IS PLACED.  
L1 MAX AND D MAX REFER RESPECTIVELY TO THE MAX AVAILABLE THICKNESS AND THE MAX AVAILABLE DIAMETER OF THE PART.  
(\* ) ALSO AVAILABLE WITH THE SPHERICAL BALL JOINT VERSION WITH 2RS, WITH BEARING SRC... OR SRL... . AVAILABILITY AND PRICES UPON REQUEST.  
**POSSIBLE TO SUPPLY SPECIAL ROD ENDS WITH MAINTANANCE FREE SPHERICAL BEARING.**  
**(SEE THE SPHERICAL BEARINGS CATALOGUE FOR SERIES: SRB..., SRT...-2RS, SRLB..., SRLT...-2RS, SR...TGR, SR...TG3A...-2RS).**  
**THESE ARTICLES ARE AVAILABLE WITHOUT GREASE NIPPLES.**

**TAPR...U GAS  
(CGAS)**

TERMINALI A SNODO  
SNODO SFERICO ISO 12240-1 SERIE E  
RILUBRIFICABILI  
ACCOPPIAMENTO ACCIAIO SU ACCIAIO

ROD ENDS  
SPHERICAL BEARING ISO 12240-1 SERIES E  
WITH GREASE NIPPLE  
COUPLING: STEEL/STEEL

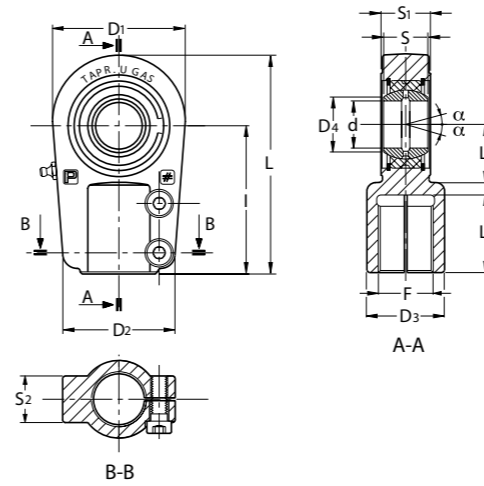

INGRASSATORE 1/8" GAS DA d 25 A d 50  
GRASE NIPPLE 1/8" GAS FROM d 25 TO d 50

INGRASSATORE 1/4" GAS DA d 60 A d 160  
GRASE NIPPLE 1/4" GAS FROM d 60 TO d 160

SIGLA ARTICLE (*)	d	d	s	S	D4	I	D1	D2	S1	S2	L	L1	D3	LF min	F	FATTORI DI CARICO LIMITE LOAD FACTORS		GIUOCO SNODO RADIALE RADIAL CLEARANCE	ANGOLO DI OSCILLAZIONE C <sub>α</sub> SWINGING ANGLE C <sub>α</sub> GRADI RATES	VITE K UNI 5931 SCREW K UNI 5931	COPPIA DI SERRAGGIO VITI Nm SCREWS CLOSING COUPLE Nm	PESO IN Kg WEIGHT Kg
																C Dinamico Dynamic	C <sub>0</sub> Statico Static					
TAPR25UGAS	25	0+-0.010	0+-0.12	20	29.3	65	56	48	23	21	95	25	28	30	M18x2	48	76	0.037-0.100	8	M8x2.0	20	0.65
TAPR30UGAS	30	0+-0.010	0+-0.12	22	34.2	75	64	56	28	26	109	30	34	35	M24x2	62	112	0.037-0.100	7	M8X2.2	20	1.0
TAPR35UGAS	35	0+-0.012	0+-0.12	25	39.7	90	78	70	30	28	132	40	44	45	M30x2	80	180	0.037-0.100	7	M10X30	40	1.3
TAPR40UGAS	40	0+-0.012	0+-0.12	28	45.0	105	94	78	35	33	155	45	55	55	M39x3	100	295	0.043-0.120	7	M12X30	80	2.4
TAPR50UGAS	50	0+-0.012	0+-0.12	35	56.0	135	116	88	40	36	198	55	70	75	M50x3	156	445	0.043-0.120	7	M12X35	80	4.1
TAPR60UGAS	60	0+-0.015	0+-0.15	44	66.8	170	130	118	50	46	240	65	87	95	M64x3	245	530	0.043-0.120	7	M16X45	160	6.5
TAPR70UGAS(1)	70	0+-0.015	0+-0.15	49	77.8	195	154	138	55	51	278	75	105	110	M80x3	315	720	0.055-0.142	6	M16X50	160	9.5
TAPR80UGAS(1)	80	0+-0.015	0+-0.15	55	89.4	210	176	168	60	55	305	80	125	120	M90x3	400	890	0.055-0.142	6	M20X55	300	16
TAPR90UGAS(1)	90	0+-0.020	0+-0.20	60	98.1	250	206	180	65	60	363	90	150	140	M100x3	490	1300	0.055-0.142	5	M20x60	300	28
TAPR100UGAS(1)	100	0+-0.020	0+-0.20	70	109.5	275	230	188	70	65	400	105	170	150	M110x4	610	1490	0.065-0.165	7	M20x65	300	34
TAPR110UGAS(1)	110	0+-0.020	0+-0.20	70	121.2	300	264	210	80	74	442	115	180	160	M120x4	650	2050	0.065-0.165	6	M24x75	500	44
TAPR120UGAS(1)	120	0+-0.020	0+-0.20	85	135.5	360	340	240	90	84	540	140	210	190	M150x4	950	2970	0.065-0.165	6	M24x85	500	75
TAPR140UGAS(1)	140	0+-0.025	0+-0.25	90	155.8	420	380	256	110	105	620	185	230	210	M160x4	1080	3350	0.065-0.165	7	M30X105	1100	160
TAPR160UGAS(1)(2)	160	0+-0.025	0+-0.25	105	170.2	460	480	290	110	105	710	200	260	230	M180x4	1370	4300	0.100-0.192	8	M30X105	1100	185

(1) MATERIALE : GHISA SFEROIDALE.  
(2) FORNIBILE SU RICHIESTA  
(\* ) FORNIBILI ANCHE NELLA VERSIONE CON SNODO SFERICO RADIALE CON TENUTA 2RS, CON SNODO SRC... OPPURE SRL... . DISPONIBILITA' E PREZZO A RICHIESTA  
**E' POSSIBILE LA FORNITURA DI TERMINALI SPECIALI DOTATI DI SNODO SFERICO ESENTE DA MANUTENZIONE.**  
**(VEDI CATALOGO SNODI SFERICI SERIE: SRB..., SRT...-2RS, SRLB..., SRLT...-2RS, SR...TGR, SR...TG3A...-2RS).**  
**PERTANTO I PEZZI SARANNO PRIVI DI INGRASSATORE.**

(1) MATERIAL: NODULAR CAST IRON  
(2) AVAILABILITY ON REQUEST  
(\* ) ALSO AVAILABLE WITH THE SPHERICAL BALL JOINT VERSION WITH 2RS, WITH BEARING SRC... OR SRL... . AVAILABILITY AND PRICES UPON REQUEST.  
**POSSIBLE TO SUPPLY SPECIAL ROD ENDS WITH MAINTANANCE FREE SPHERICAL BEARING.**  
**(SEE THE SPHERICAL BEARINGS CATALOGUE FOR SERIES: SRB..., SRT...-2RS, SRLB..., SRLT...-2RS, SR...TGR, SR...TG3A...-2RS).**  
**THESE ARTICLES ARE AVAILABLE WITHOUT GREASE NIPPLES.**

TUTTI I TERMINALI POSSONO ESSERE PRODOTTI SU RICHIESTA IN ACCIAIO INOSSIDABILE. ALCUNE DIMENSIONI POSSONO DIFFERIRE DAL CATALOGO.  
ALL ROD ENDS CAN BE MADE OF STAINLESS STEEL. WE INFORM THAT SOME DIMENSIONS MIGHT BE DIFFERENT, FROM THE DIMENSIONS IN THE CATALOGUE

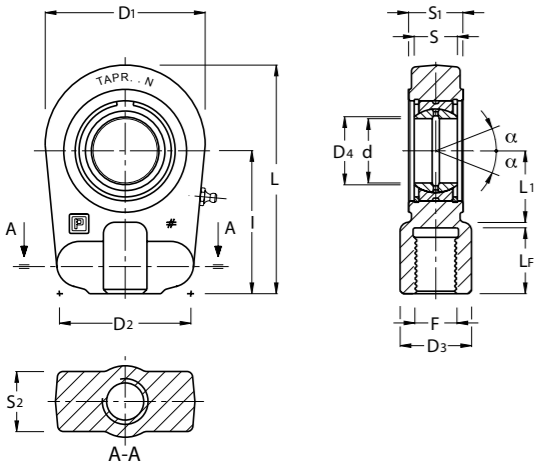

**TAPR...N**

TERMINALI A SNODO  
SNODO SFERICO ISO 12240-1 SERIE E  
RILUBRIFICABILI  
ACCOPPIAMENTO ACCIAIO SU ACCIAIO

ROD ENDS  
SPHERICAL BEARING ISO 12240-1 SERIES E  
WITH GREASE NIPPLE  
COUPLING: STEEL/STEEL



SIGLA (*) ARTICLE (*)	TOLLERANZE TOLERANCES		S	D4	I	D1 max	D2	S1 max	S2	L	L1 min	D3 max	LF min	F	FATTORI DI CARICO LIMITE LOAD FACTORS		GIUOCO SNODO RADIALE RADIAL CLEARANCE	ANGOLO DI OSCILLAZIONE C. SWINGING ANGLE C. α°	PESO IN Kg WEIGHT Kg			
	d	S													C Dinamico Dynamic	Co Statico Static						
mm.																			KN		mm.	
TAPR 20 N	20	0 ± -0.010	0 ± -0.12	16	24.1	50	58	46	19	17	80	25	26.5	17	M 16X1,5	30	81.1	0.040 - 0.082	9	0.45		
TAPR 25 N	25	0 ± -0.010	0 ± -0.12	20	29.3	50	58	46	23.5	21	80	28	26.5	17	M 16X1.5	48	72	0.050 - 0.100	7	0.49		
TAPR 30 N	30	0 ± -0.010	0 ± -0.12	22	34.2	60	66	50	28.5	26	94	30	33	23	M 22X1.5	62	106	0.050 - 0.100	6	0.76		
TAPR 35 N	35	0 ± -0.012	0 ± -0.12	25	39.7	70	80	66	30.5	28	112	38	41	29	M 28X1.5	80	153	0.050 - 0.100	6	1.26		
TAPR 40 N	40	0 ± -0.012	0 ± -0.12	28	45	85	96	76	35.5	33	135	45	50	36	M 35X1.5	100	250	0.060 - 0.120	7	2.15		
TAPR 50 N	50	0 ± -0.012	0 ± -0.12	35	56	105	118	90	40.5	37	168	55	62	46	M 45X1.5	156	365	0.060 - 0.120	6	3.80		
TAPR 60 N	60	0 ± -0.015	0 ± -0.15	44	66.8	130	132	120	50.5	46	200	65	76	59	M 58X1.5	245	400	0.060 - 0.120	6	6.20		
TAPR 70 N	70	0 ± -0.015	0 ± -0.15	49	77.8	150	157	130	55.5	51	232	75	87.5	66	M 65X1.5	315	540	0.072 - 0.142	6	9.83		
TAPR 80 N	80	0 ± -0.015	0 ± -0.15	55	89.4	170	179	160	60.5	55	265	80	107	81	M 80X2	400	670	0.072 - 0.142	6	13.97		
TAPR 90 N (1)	90	0 ± -0.020	0 ± -0.20	60	98.1	210	208	180	65.5	60	322	90	126	101	M100X2	490	980	0.072 - 0.142	5	23.50		
TAPR 100 N (1)	100	0 ± -0.020	0 ± -0.20	70	109.5	235	233.5	200	70.5	65	360	105	139	111	M110X2	610	1120	0.085 - 0.165	7	32.00		
TAPR 110 N (1)	110	0 ± -0.020	0 ± -0.20	70	121.2	265	268	220	80.5	74	407	115	154	125	M120X3	655	1700	0.085 - 0.165	6	41.00		
TAPR 120 N (1)	120	0 ± -0.020	0 ± -0.20	85	135.5	310	345	257	90.5	84	490	140	174	135	M130X3	950	2900	0.085 - 0.165	6	72.00		

(1) MATERIALE : GHISA SFEROIDALE.  
(\*) FORNIBILI ANCHE NELLA VERSIONE CON SNODO SFERICO RADIALE CON TENUTA - (...-2RS ), CON SNODO SFERICO SRC... OPPURE SRL... . DISPONIBILITA' E PREZZO A RICHIESTA.  
(\*) NEL CASO DI RICHIESTA CON FILETTATURA SINISTRORSA SOSTITUIRE NEL COD. ART. LA LETTERA "R" CON "L" ES. TAPL...N - DISPONIBILITA' E PREZZO A RICHIESTA.  
**E' POSSIBILE LA FORNITURA DI TERMINALI SPECIALI DOTATI DI SNODO SFERICO ESENTE DA MANUTENZIONE.**  
**(VEDI SNODI SFERICI SERIE: SRB..., SRT...-2RS, SRLB..., SRLT...-2RS, SR...TGR, SR...TG3A...-2RS). PERTANTO I PEZZI SARANNO PRIVI DI INGRASSATORE.**

(1) MATERIAL: NODULAR CAST IRON.  
(\*) ALSO AVAILABLE WITH SPHERICAL PLAIN BEARING WITH 2RS-RING, WITH SPHERICAL BEARING SRC... OR SRL... . AVAILABILITY AND PRICES UPON REQUEST.  
(\*) WHEN REQUIRING A LEFT-END THREAD, REPLACE THE ARTICLE CODE LETTER "R" WITH "L", (e.g.: TAPL... N). AVAILABILITY AND PRICES UPON REQUEST.  
**POSSIBLE TO SUPPLY SPECIAL ROD ENDS WITH MAINTANANCE FREE SPHERICAL BEARING.**  
**(SEE THE SPHERICAL BEARINGS FOR SERIES : SRB, SRT...-2RS, SRLB, SRLT...-2RS, SR...TGR, SR...TG3A...-2RS). THESE ARTICLES ARE AVAILABLE WITHOUT GREASE NIPPLES.**

TUTTI I TERMINALI POSSONO ESSERE PRODOTTI SU RICHIESTA IN ACCIAIO INOSSIDABILE. ALCUNE DIMENSIONI POSSONO DIFFERIRE DAL CATALOGO.  
ALL ROD ENDS CAN BE MADE OF STAINLESS STEEL. WE INFORM THAT SOME DIMENSIONS MIGHT BE DIFFERENT, FROM THE DIMENSIONS IN THE CATALOGUE

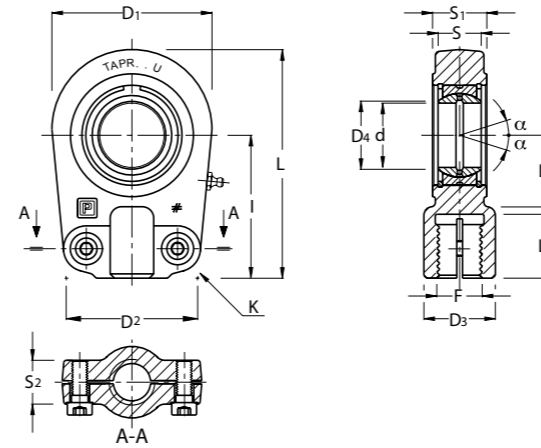

**TAPR...U**  
**(SIR...ES; GIHRK...DO)**

TERMINALI A SNODO  
SNODO SFERICO ISO 12240-1 SERIE E  
RILUBRIFICABILI  
ACCOPPIAMENTO ACCIAIO SU ACCIAIO

ROD ENDS  
SPHERICAL BEARING ISO 12240-1 SERIES E  
WITH GREASE NIPPLE  
COUPLING: STEEL/STEEL



SIGLA (*) ARTICLE (*)	TOLLERANZE TOLERANCES		S	D4	I	D1 max	D2	S1 max	S2	L	L1 min	D3 max	LF min	F	FATTORI DI CARICO LIMITE LOAD FACTORS		GIUOCO SNODO RADIALE RADIAL CLEARANCE	ANGOLO DI OSCILLAZIONE C. SWINGING ANGLE C. α°	VITE K UNI 5931 SCREWS K UNI 5931	COPPA DISERRAGGIO VITI Nm SCREWS TORQUE Nm	PESO IN Kg WEIGHT Kg	
	d	S													C Dinamico Dynamic	Co Statico Static						
mm.																			KN		mm.	
TAPR 20 U	20	0 ± -0.010	0 ± -0.12	16	24.1	50	58	46	19	17	80	25	26.5	17	M 16X1,5	30	81.1	0.040 - 0.082	9	M 8X18	25	0.44
TAPR 25 U	25	0 ± -0.010	0 ± -0.12	20	29.3	50	58	46	23.5	21	80	28	26.5	17	M 16X1.5	48	72	0.050 - 0.100	7	M 8X20	25	0.47
TAPR 30 U	30	0 ± -0.010	0 ± -0.12	22	34.2	60	66	50	28.5	26	94	30	33	23	M 22X1.5	62	106	0.050 - 0.100	6	M 8X25	25	0.77
TAPR 35 U	35	0 ± -0.012	0 ± -0.12	25	39.7	70	80	66	30.5	28	112	38	41	29	M 28X1.5	80	153	0.050 - 0.100	6	M10X30	49	1.24
TAPR 40 U	40	0 ± -0.012	0 ± -0.12	28	45	85	96	76	35.5	33	135	45	50	36	M 35X1.5	100	250	0.060 - 0.120	7	M10X35	49	2.12
TAPR 50 U	50	0 ± -0.012	0 ± -0.12	35	56	105	118	90	40.5	37	168	55	62	46	M 45X1.5	156	365	0.060 - 0.120	6	M12X40	86	3.74
TAPR 60 U	60	0 ± -0.015	0 ± -0.15	44	66.8	130	132	120	50.5	46	200	65	76	59	M 58X1.5	245	400	0.060 - 0.120	6	M16X45	210	6.49
TAPR 70 U	70	0 ± -0.015	0 ± -0.15	49	77.8	150	157	130	55.5	51	232	75	87.5	66	M 65X1.5	315	540	0.072 - 0.142	6	M16X50	210	9.88
TAPR 80 U	80	0 ± -0.015	0 ± -0.15	55	89.4	170	179	160	60.5	55	265	80	107	81	M 80X2	400	670	0.072 - 0.142	6	M20X55	410	14.20
TAPR 90 U (1)	90	0 ± -0.012	0 ± -0.20	60	98.1	210	208	180	65.5	60	322	90	126	101	M100X2	490	980	0.072 - 0.142	5	M20X60	410	20.00
TAPR 100 U (1)	100	0 ± -0.012	0 ± -0.20	70	109.5	235	233.5	200	70.5	65	360	105	139	111	M110X2	610	1120	0.085 - 0.165	7	M24X65	710	27.50
TAPR 110 U (1)	110	0 ± -0.012	0 ± -0.20	70	121.2	265	268	220	80.5	74	407.5	115	154	125	M120X3	655	1700	0.085 - 0.165	6	M24X80	710	45.60
TAPR 120 U (1)	120	0 ± -0.012	0 ± -0.20	85	135.5	310	345	257	90.5	84	490	140	174	135	M130X3	950	2900	0.085 - 0.165	6	M24X85	710	72.00

(1) MATERIALE : GHISA SFEROIDALE.  
(\*) FORNIBILI ANCHE NELLA VERSIONE CON SNODO SFERICO RADIALE CON TENUTA - (...-2RS ), CON SNODO SFERICO SRC... OPPURE SRL... . DISPONIBILITA' E PREZZO A RICHIESTA.  
(\*) NEL CASO DI RICHIESTA CON FILETTATURA SINISTRORSA SOSTITUIRE NEL COD. ART. LA LETTERA "R" CON "L" ES. TAPL...U - DISPONIBILITA' E PREZZO A RICHIESTA.  
**E' POSSIBILE LA FORNITURA DI TERMINALI SPECIALI DOTATI DI SNODO SFERICO ESENTE DA MANUTENZIONE.**  
**(VEDI SNODI SFERICI SERIE: SRB..., SRT...-2RS, SRLB..., SRLT...-2RS, SR...TGR, SR...TG3A...-2RS). PERTANTO I PEZZI SARANNO PRIVI DI INGRASSATORE.**

(1) MATERIAL: NODULAR CAST IRON.  
(\*) ALSO AVAILABLE WITH SPHERICAL PLAIN BEARING WITH 2RS-RING, WITH SPHERICAL BEARING SRC... OR SRL... . AVAILABILITY AND PRICES UPON REQUEST.  
(\*) WHEN REQUIRING A LEFT-END THREAD, REPLACE THE ARTICLE CODE LETTER "R" WITH "L", (e.g.: TAPL...U). AVAILABILITY AND PRICES UPON REQUEST.  
**POSSIBLE TO SUPPLY SPECIAL ROD ENDS WITH MAINTANANCE FREE SPHERICAL BEARING.**  
**(SEE THE SPHERICAL BEARINGS FOR SERIES : SRB, SRT...-2RS, SRLB, SRLT...-2RS, SR...TGR, SR...TG3A...-2RS). THESE ARTICLES ARE AVAILABLE WITHOUT GREASE NIPPLES.**

TUTTI I TERMINALI POSSONO ESSERE PRODOTTI SU RICHIESTA IN ACCIAIO INOSSIDABILE. ALCUNE DIMENSIONI POSSONO DIFFERIRE DAL CATALOGO.  
ALL ROD ENDS CAN BE MADE OF STAINLESS STEEL. WE INFORM THAT SOME DIMENSIONS MIGHT BE DIFFERENT, FROM THE DIMENSIONS IN THE CATALOGUE

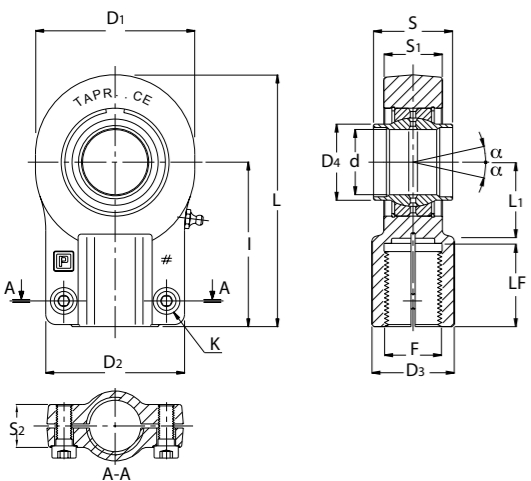

**TAPR...CE**  
(SIQG...ES; GIHNRK...LO)

TERMINALI A SNODO

DIN 24338 - ISO 8132  
RILUBRIFICABILI  
ACCOPPIAMENTO ACCIAIO SU ACCIAIO

ROD ENDS

DIN 24338 - ISO 8132  
WITH GREASE NIPPLE  
COUPLING: STEEL/STEEL



**TAPR...S**  
(SIJ...ES)

TERMINALI A SNODO

DIN 24555 - ISO 8133  
RILUBRIFICABILI  
ACCOPPIAMENTO: ACCIAIO SU ACCIAIO

ROD ENDS

DIN 24555 - ISO 8133  
WITH GREASE NIPPLE  
COUPLING: STEEL/STEEL

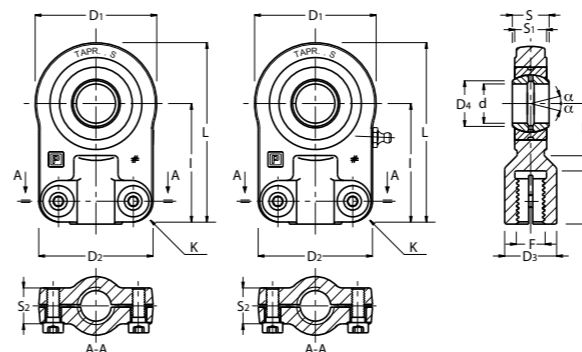

SIGLA (*) ARTICLE (*)	TOLLERANZE TOLERANCES		S	D4	I	D1 max	D2	S1 max	S2	L	L1 min	D3 max	LF min	F	FATTORI DI CARICO LIMITE LOAD FACTORS		GIUOCO SNODO RADIALE RADIAL CLEARANCE	ANGOLO DI OSCILLAZIONE C <sub>2</sub> SWINGING ANGLE C <sub>2</sub>	VITE K UNI 5931 SCREWS K UNI 5931	COPPA DI SERRAGGIO VITI Nm SCREWS TORQUE Nm	PESO IN Kg WEIGHT Kg	
	d	S													C <sub>D</sub> Dynamic	C <sub>S</sub> Static						
mm.																						
TAPR 12 CE (1)	12	0+/-0.018	0+/-0.18	12	15.5	38	33	32	11	15	54	14	17	17	M12 X1.25	10.8	24.5	0.032 - 0.068	4	M 5X16	6	0.11
TAPR 16 CE	16	0+/-0.018	0+/-0.18	16	20	44	41	40	14	15	64	20	22	19	M14 X1.5	17.6	36.5	0.040 - 0.082	4	M 6X14	10	0.20
TAPR 20 CE	20	0+/-0.021	0+/-0.21	20	25	52	48	47	17.5	19	77	22	26	23	M16 X1.5	30	48	0.040 - 0.082	4	M 8X20	25	0.35
TAPR 25 CE	25	0+/-0.021	0+/-0.21	25	30.5	65	59.5	54	22	19	96	27	31	29	M20 X1.5	48	78	0.050 - 0.100	4	M 8X20	25	0.62
TAPR 32 CE	32	0+/-0.025	0+/-0.25	32	38	80	72	66	28	22	118	32	39	37	M27 X2	67	114	0.050 - 0.100	4	M10X25	49	1.15
TAPR 40 CE	40	0+/-0.025	0+/-0.25	40	46	97	91.5	80	34	26	146	41	48	46	M33 X2	100	204	0.060 - 0.120	4	M10X30	49	2.18
TAPR 50 CE	50	0+/-0.025	0+/-0.25	50	57	120	110.5	96	42	32	179	50	59	57	M42 X2	156	310	0.060 - 0.120	4	M12X35	86	3.96
TAPR 63 CE	63	0+/-0.030	0+/-0.30	63	71.5	140	137.5	114	53.5	38	213	62	71	64	M48 X2	255	430	0.072 - 0.142	4	M16X40	210	6.80
TAPR 70 CE(2)(A)	70	0+/-0.030	0+/-0.30	70	79	160	158	135	58	42	245	70	81	76	M56 X2	315	540	0.072 - 0.142	4	M16X40	210	9.60
TAPR 80 CE(2)	80	0+/-0.030	0+/-0.30	80	91	180	171.5	148	68	48	270	78	91	86	M64 X3	400	695	0.072 - 0.142	4	M20X50	410	13.00
TAPR 90 CE(2)(A)	90	0+/-0.035	0+/-0.35	90	99	195	187	160	73	52	296	85	102	91	M72 X3	490	750	0.072 - 0.142	4	M20X60	410	19.10
TAPR100 CE(2)	100	0+/-0.035	0+/-0.35	100	113	210	212.5	178	85.5	62	322	98	112	96	M80 X3	610	1060	0.085 - 0.165	4	M24X60	710	25.00
TAPR110 CE(2)(A)	110	0+/-0.035	0+/-0.35	110	124	235	237	190	89	62	364	105	127	106	M90 X3	655	1200	0.085 - 0.165	4	M24X60	710	32.00
TAPR125 CE(2)(B)	125	0+/-0.040	0+/-0.40	125	138	260	268	200	105	72	406.5	120	135	113	M100X3	950	1430	0.085 - 0.165	4	M24X70	710	46.00
TAPR160 CE(2)(B)	160	0+/-0.040	0+/-0.40	160	177	310	328	250	133	82	488	150	165	126	M125X4	1370	2200	0.100 - 0.192	4	M24X80	710	82.50
TAPR200 CE(2)(B)	200	0+/-0.046	0+/-0.46	200	221	390	420	320	165	102	620	195	215	161	M160X4	2120	3650	0.100 - 0.192	4	M30X100	1500	168.00

(1) NON RILUBRIFICABILE.  
(2) MATERIALE: GHISA SFEROIDALE.  
(\*) NEL CASO DI RICHIESTA CON FILETTATURA SINISTRORSA SOSTITUIRE NEL COD. ART. LA LETTERA "R" CON "L" ES. TAPL...CE. FORNIBILI ANCHE CON SNODI SFERICI SR... , SRL... OPPURE SRC...-2RS.  
DISPONIBILITA' E PREZZO A RICHIESTA.  
**E' POSSIBILE LA FORNITURA DI TERMINALI SPECIALI DOTATI DI SNODO SFERICO ESENTE DA MANUTENZIONE.**  
**(VEDI SNODI SFERICI SERIE: SRB..., SRT...-2RS, SRLB..., SRLT...-2RS, SR...TGR, SR...TG3A...-2RS). PERTANTO I PEZZI SARANNO PRIVI DI INGRASSATORE O FORO OLIAIORE.**

(1) NON LUBRICATING  
(2) MATERIAL: NODULAR CAST IRON.  
(\*) WHEN REQUIRING A LEFT-END THREAD, REPLACE THE ARTICLE CODE LETTER "R" WITH "L", (e.g.: TAPL...CE), POSSIBLE TO SUPPLY WITH SPHERICALS BEARINGS SR... , SRL... OR SRC...-2RS.  
AVAILABILITY AND PRICES UPON REQUEST.  
**POSSIBLE TO SUPPLY SPECIAL ROD ENDS WITH MAINTANANCE FREE SPHERICAL BEARING.**  
**(SEE THE SPHERICAL BEARINGS FOR SERIES: SRB, SRT...-2RS, SRLB, SRLT...-2RS, SR...TGR, SR...TG3A...-2RS). THESE ARTICLES ARE AVAILABLE WITHOUT GREASE NIPPLES OR LUBRICATION HOLES.**

(A) FUORI NORMATIVA - OUT OF STANDARD  
(B) INGRASSATORE M8 - GREASE NIPPLE M8

TUTTI I TERMINALI POSSONO ESSERE PRODOTTI SU RICHIESTA IN ACCIAIO INOSSIDABILE. ALCUNE DIMENSIONI POSSONO DIFFERIRE DAL CATALOGO.  
ALL ROD ENDS CAN BE MADE OF STAINLESS STEEL. WE INFORM THAT SOME DIMENSIONS MIGHT BE DIFFERENT, FROM THE DIMENSIONS IN THE CATALOGUE

**TAPR 12 S-TAPR 20 S TAPR 25 S-TAPR 100 S**

SIGLA (*) ARTICLE (*)	TOLLERANZE TOLERANCES		S	D4	I	D1 max	D2	S1 max	S2	L	L1 min	D3 max	LF min	F	FATTORI DI CARICO LIMITE LOAD FACTORS		GIUOCO SNODO RADIALE RADIAL CLEARANCE	ANGOLO DI OSCILLAZIONE C <sub>2</sub> SWINGING ANGLE C <sub>2</sub>	VITE K UNI 5931 SCREWS K UNI 5931	COPPA DI SERRAGGIO VITI Nm SCREWS TORQUE Nm	PESO IN Kg WEIGHT Kg	
	d	S													C <sub>D</sub> Dynamic	C <sub>S</sub> Static						
mm.																						
TAPR 12 S (1)	12	0+/-0.008	0+/-0.12	10	15	42	35	40	8	13	58	16	17	15	M10X1.25	10.8	17	0.032 - 0.068	11	M 6X14	10	0.12
TAPR 16 S (2)(A)	16	0+/-0.008	0+/-0.12	14	20.7	48	45	45	11	13	69	20	21	17	M12X1.25	21.1	28.5	0.040 - 0.082	10	M 6X14	10	0.22
TAPR 20 S (2)	20	0+/-0.010	0+/-0.12	16	24.1	58	55	55	13	17	83	28	25	19	M14X1.5	30	42.5	0.040 - 0.082	9	M 8X18	25	0.43
TAPR 25 S	25	0+/-0.010	0+/-0.12	20	29.3	68	65	62	17	17	99	31	30	23	M16X1.5	48	67	0.050 - 0.100	7	M 8X18	25	0.67
TAPR 30 S	30	0+/-0.010	0+/-0.12	22	34.2	85	80	77	19	19	123	35	36	29	M20X1.5	62	108	0.050 - 0.100	6	M10X20	49	1.25
TAPR 40 S	40	0+/-0.012	0+/-0.12	28	45	105	100	90	23	23	153	45	45	37	M27X2	100	156	0.060 - 0.120	7	M10X25	49	2.16
TAPR 50 S	50	0+/-0.012	0+/-0.12	35	56	130	120	105	30	30	188	58	55	46	M33X2	156	245	0.060 - 0.120	6	M12X30	86	3.90
TAPR 60 S	60	0+/-0.015	0+/-0.15	44	66.8	150	160	134	38	38	230	68	68	57	M42X2	245	380	0.060 - 0.120	6	M16X40	210	7.15
TAPR 80 S (3)	80	0+/-0.015	0+/-0.15	55	89.4	185	205	156	46	47	287.5	82	90	64	M48X2	400	585	0.072 - 0.142	6	M20X50	410	15.00
TAPR 100 S (3)	100	0+/-0.020	0+/-0.20	70	109.5	240	240	190	55	55	357.5	116	110	86	M64X3	610	865	0.085 - 0.165	7	M24X60	710	27.30

(1) NON RILUBRIFICABILE. (2) RILUBRIFICABILE MEDIANTE UN FORO DI LUBRIFICAZIONE SULLA TESTA Ø2.5. - (3) MATERIALE GHISA SFEROIDALE.  
FORNIBILI ANCHE NELLA VERSIONE CON NODO SFERICO RADIALE CON TENUTA (...2RS), CON NODO SFERICO SRC... OPPURE SRL... . DISPONIBILITA' E PREZZO A RICHIESTA.  
(\*) NEL CASO DI RICHIESTA CON FILETTATURA SINISTRORSA SOSTITUIRE NEL COD. ART. LA LETTERA "R" CON "L" ES. TAPL...S. - DISPONIBILITA' E PREZZO A RICHIESTA.  
**E' POSSIBILE LA FORNITURA DI TERMINALI SPECIALI DOTATI DI SNODO SFERICO ESENTE DA MANUTENZIONE.**  
**(VEDI SNODI SFERICI SERIE: SRB..., SRT...-2RS, SRLB..., SRLT...-2RS, SR...TGR, SR...TG3A...-2RS). PERTANTO I PEZZI SARANNO PRIVI DI INGRASSATORE O FORO OLIAIORE.**

(1) NON LUBRICATING (2) LUBRICATING BY A LUBRICATION OPENING ON THE HEAD Ø2.5.  
(3) MATERIAL: NODULAR CAST IRON. ALSO SUPPLIABLE IN THE SPHERICAL BALL JOINT VERSION WITH 2RS, WITH SPHERICAL BEARING SRC... OR SRN... . AVAILABILITY AND PRICES UPON REQUEST.  
(\*) WHEN REQUIRING A LEFT-END THREAD, REPLACE THE ARTICLE CODE LETTER "R" WITH "L", (e.g.: TAPL...S). AVAILABILITY AND PRICES UPON REQUEST.  
**POSSIBLE TO SUPPLY SPECIAL ROD ENDS WITH MAINTANANCE FREE SPHERICAL BEARING.**  
**(SEE THE SPHERICAL BEARINGS FOR SERIES: SRB, SRT...-2RS, SRLB, SRLT...-2RS, SR...TGR, SR...TG3A...-2RS). THESE ARTICLES ARE AVAILABLE WITHOUT GREASE NIPPLES OR LUBRICATION HOLES.**

(A) FUORI NORMATIVA - OUT OF STANDARD

TUTTI I TERMINALI POSSONO ESSERE PRODOTTI SU RICHIESTA IN ACCIAIO INOSSIDABILE. ALCUNE DIMENSIONI POSSONO DIFFERIRE DAL CATALOGO.  
ALL ROD ENDS CAN BE MADE OF STAINLESS STEEL. WE INFORM THAT SOME DIMENSIONS MIGHT BE DIFFERENT, FROM THE DIMENSIONS IN THE CATALOGUE

**TFI...FK**  
**TFI...FK MAG.**  
**TFI...FK-2RS**  
**TFI...FK-2RS MAG.**  
**(SI...E; SI...ES; SI...ES-2RS; SIA...ES-2RS; GIR...DO; GIR...DO-2RS)**

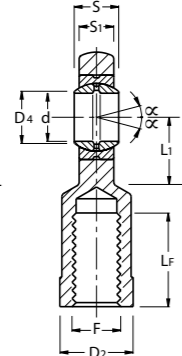
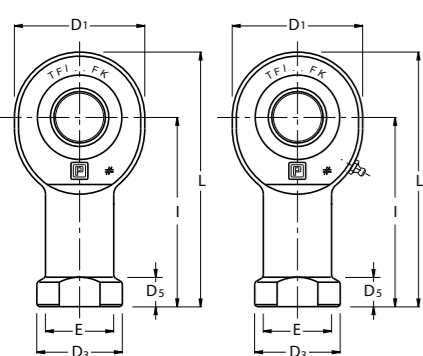

TERMINALI A SNODO  
 ISO 12240-4, SERIE E TIPO F  
 RILUBRIFICABILI  
 ACCOPPIAMENTO: ACCIAIO SU ACCIAIO  
 TERMINALE IN ACCIAIO C45 ZINCATO  
 ROD ENDS  
 ISO 12240-4, SERIES E TYPE F  
 WITH GREASE NIPPLE  
 COUPLING: STEEL/STEEL  
 HOUSING MADE OF STEEL C45 ZINC PLATED



TFI 6 FK - TFI 20 FK    TFI 25 FK - TFI 80 FK

SIGLA (*) ARTICLE (*)	TOLLERANZE TOLERANCES		S	D4	I	D1	D3	E	D2	D5	S1	L	L1	LF min	F	FATTORI DI CARICO LIMITE LOAD FACTORS		GIUOCO SNODO RADIALE RADIAL CLEARANCE	ANGOLO DI OSCILLAZIONE C <sub>α</sub> SWINGING ANGLE C <sub>α</sub>	PESO IN Kg. WEIGHT Kg.	
	d	S														C	C <sub>0</sub>				
	mm.																				KN
TFI 6 FK (1)	6	0 ± -0.008	0 ± -0.12	6	8	30	21	13	10.5	11	5	4.3	40.5	10.5	11	M 6X1	3.4	8.1	0.032 - 0.068	13	0.02
TFI 8 FK (1)	8	0 ± -0.008	0 ± -0.12	8	10.2	36	24	15	12	13	5	6	48	12	15	M 8X1.25	5.5	12.9	0.032 - 0.068	15	0.04
TFI 10 FK (1)	10	0 ± -0.008	0 ± -0.12	9	13.2	43	29	18	15	15	6.5	7	57.5	14	20	M10X1.5	8.1	17.6	0.032 - 0.068	12	0.06
TFI 12 FK (1)	12	0 ± -0.008	0 ± -0.12	10	15	50	34	20	17	18	6.5	8	67	17.5	24	M12X1.75	10.8	24.5	0.040 - 0.068	11	0.09
TFI 15 FK (2RS)	15	0 ± -0.008	0 ± -0.12	12	18.4	61	40	24	20	21	8	10	81	20	30	M14X2	17	36	0.040 - 0.082	8	0.18
TFI 17 FK (2RS)	17	0 ± -0.008	0 ± -0.12	14	20.7	67	46	28	23	24	10	11	90	23	34	M16X2	21.2	45	0.040 - 0.082	10	0.22
TFI 20 FK (2RS)	20	0 ± -0.010	0 ± -0.12	16	24.1	77	53	35	27.5	32	10	13	103.5	27.5	40	M20X1.5	30	60	0.050 - 0.082	9	0.35
TFI 25 FK (2RS)	25	0 ± -0.010	0 ± -0.12	20	29.3	94	64	42	33.5	36	12	17	126	32	48	M24X2	48	83	0.050 - 0.082	7	0.64
TFI 30 FK (2RS)	30	0 ± -0.010	0 ± -0.12	22	34.2	110	73	50	40	41	15	19	146.5	37	56	M30X2	62	110	0.050 - 0.100	6	0.93
TFI 35 FK (2RS)	35	0 ± -0.012	0 ± -0.12	25	39.7	125	82	58	47	50	15	21	166	42	60	M36X3	80	146	0.060 - 0.100	6	1.30
TFI 40 FK (2RS)	40	0 ± -0.012	0 ± -0.12	28	45	142	92	65	52	55	18	23	188	48	67	M39X3	100	180	0.060 - 0.120	7	2.01
TFI 45 FK (2RS)	45	0 ± -0.012	0 ± -0.12	32	50.7	145	102	70	58	60	20	27	196	52	65	M42X3	127	240	0.060 - 0.120	7	2.50
TFI 50 FK (2RS)	50	0 ± -0.012	0 ± -0.12	35	56	160	112	75	62	65	20	30	216	59	69	M45X3	156	290	0.060 - 0.120	6	3.50
TFI 60 FK (2RS)	60	0 ± -0.015	0 ± -0.15	44	66.8	175	135	88	70	75	20	38	242	75	73	M52X3	245	450	0.072 - 0.120	6	5.90
TFI 70 FK (2RS)	70	0 ± -0.015	0 ± -0.15	49	77.8	200	160	98	80	85	20	42	280	87	80	M56X4	315	610	0.072 - 0.142	6	8.60
TFI 80 FK (2RS)	80	0 ± -0.015	0 ± -0.15	55	89.4	230	180	110	95	100	25	47	320	100	85	M64X4	400	695	0.072 - 0.142	6	12.00
VERSIONE CON FILETTO MAGGIORATO HIGHER THREAD VERSION																					
TFI 40 FK (2RS) MAG	40	0 ± -0.012	0 ± -0.12	28	45	142	92	65	52	55	18	23	188	48	67	M42X3	100	102.5	0.060 - 0.120	7	1.96
TFI 45 FK (2RS) MAG	45	0 ± -0.012	0 ± -0.12	32	50.7	145	102	70	58	60	20	27	196	52	65	M45X3	127	141	0.060 - 0.120	7	2.44
TFI 50 FK (2RS) MAG	50	0 ± -0.012	0 ± -0.12	35	56	160	112	75	62	65	20	30	216	59	69	M52X3	156	140	0.060 - 0.120	6	3.40
TFI 60 FK (2RS) MAG	60	0 ± -0.015	0 ± -0.15	44	66.8	175	135	88	70	75	20	38	242	75	73	M60X4	245	183	0.072 - 0.120	6	6.10
TFI 70 FK (2RS) MAG	70	0 ± -0.015	0 ± -0.15	49	77.8	200	160	98	85	80	20	42	280	87	80	M72X4	315	306	0.072 - 0.142	6	8.70
TFI 80 FK (2RS) MAG	80	0 ± -0.015	0 ± -0.15	55	89.4	230	180	110	95	100	25	47	320	100	85	M80X4	400	387	0.072 - 0.142	6	13.90

(1) NON RILUBRIFICABILE.  
 (2) RILUBRIFICABILE MEDIANTE UN FORO DI LUBRIFICAZIONE SULLA TESTA.  
 (3) FORNIBILI ANCHE NELLA VERSIONE CON NODO SFERICO SRC... OPPURE SRL...  
 (\*) NEL CASO DI RICHIESTA CON FILETTATURA SINISTRORSA AGGIUNGERE NEL COD. ART. LA LETTERA "L" ES. TFI... - DISPONIBILITA'E PREZZO A RICHIESTA.

(1) NON LUBRICATING.  
 (2) LUBRICATING BY A LUBRICATION OPENING ON THE HEAD.  
 (3) ALSO AVAILABLE WITH SPHERICAL PLAIN BEARING SRC... OR SRL...  
 (\*) WHEN REQUIRING A LEFT-END THREAD, ADD THE LETTER "L" IN THE ARTICLE CODE (e.g.: TFI...), AVAILABILITY AND PRICES UPON REQUEST.

**TFI...M**  
**(SI...ES-2RS)**  
 TERMINALI A SNODO

SNODO SFERICO ISO 12240-1 SERIE E  
 RILUBRIFICABILI  
 ACCOPPIAMENTO: ACCIAIO SU ACCIAIO  
 TERMINALE IN ACCIAIO C45 ZINCATO

ROD ENDS  
 SPHERICAL BEARING ISO 12240-1 SERIES E  
 WITH GREASE NIPPLE  
 COUPLING: STEEL/STEEL  
 HOUSING MADE OF STEEL C45 ZINC PLATED

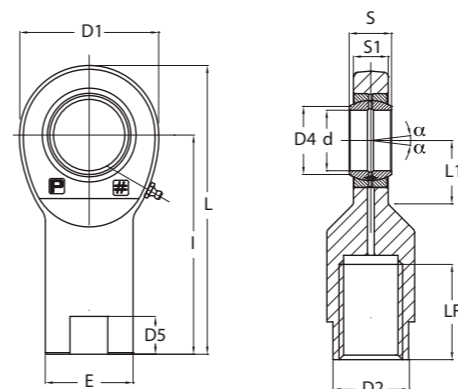

SIGLA (*) ARTICLE (*)	TOLLERANZE TOLERANCES		S	D4	I	D1	E	D2	D5	S1	L	L1	LF min	F	FATTORI DI CARICO LIMITE LOAD FACTORS		GIUOCO SNODO RADIALE RADIAL CLEARANCE	ANGOLO DI OSCILLAZIONE C <sub>α</sub> SWINGING ANGLE C <sub>α</sub>	PESO IN Kg. WEIGHT Kg.		
	d	S													C	C <sub>0</sub>					
	mm.																			KN	mm
TFI 40 M (2RS)	40	0 ± -0.012	0 ± -0.12	28	45	145	92	58	50	25	23	191	42	63	M 42X3	100	180	0.043 - 0.120	7	2.2	
TFI 50 M (2RS)	50	0 ± -0.012	0 ± -0.12	35	56	195	114	70	60	30	31	254	59	68	M 52X3	156	290	0.043 - 0.120	6	3.5	

FORNIBILE CON SNODI CON 2RS, CON SNODI SRC... SRL... ED ESENTI DA MANUTENZIONE.  
 POSSIBLE TO SUPPLY WITH SPECIAL BEARINGS 2RS, WITH BEARINGS SRC..., SRL... AND MAINTENANCE FREE.

**TFE...MK**  
**TFE...MK MAG.**  
**TFE...MK-2RS**  
**TFE...MK-2RS MAG.**  
**(SA...E; SA...ES; SA...ES-2RS; SAA...ES-2RS; GAR...DO; GAR...DO-2RS)**

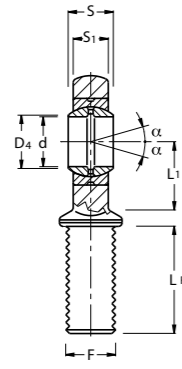
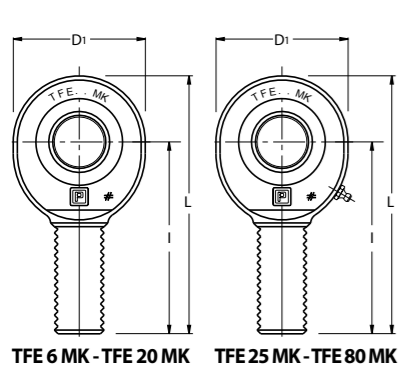

TERMINALI A SNODO  
 ISO 12240-4, SERIE E TIPO M  
 RILUBRIFICABILI  
 ACCOPPIAMENTO: ACCIAIO SU ACCIAIO  
 TERMINALE IN ACCIAIO C45 ZINCATO  
 ROD ENDS  
 ISO 12240-4, SERIES E TYPE M  
 WITH GREASE NIPPLE  
 COUPLING: STEEL/STEEL  
 HOUSING MADE OF STEEL C45 ZINC PLATED



TFE 6 MK - TFE 20 MK TFE 25 MK - TFE 80 MK

SIGLA (*) ARTICLE (*)	d	TOLLERANZE TOLERANCES		S	D4	I	D1	S1	L	L1	LF min	F	FATTORI DI CARICO LIMITE LOAD FACTORS		GIUOCO SNODO RADIALE RADIAL CLEARANCE	ANGOLO DI OSCILLAZIONE α SWINGING ANGLE α	PESO IN Kg. WEIGHT Kg.
		d	S										C Dinamico Dynamic	Co Statico Static			
mm.																	
TFE 6 MK (1)	6	0 ± -0.008	0 ± -0.12	6	8	36	21	4.3	46.5	12	18	M6X1	3.4	10.2	0.032 - 0.068	13	0.01
TFE 8 MK (1)	8	0 ± -0.008	0 ± -0.12	8	10.2	42	24	6	54	14	22	M8X1.25	5.5	16	0.032 - 0.068	15	0.03
TFE 10 MK (1)	10	0 ± -0.008	0 ± -0.12	9	13.2	48	29	7	62.5	15	27	M10X1.5	8.1	22	0.032 - 0.068	12	0.05
TFE 12 MK (1)	12	0 ± -0.008	0 ± -0.12	10	15	54	34	8	71	19	30	M12X1.75	10.8	30.4	0.040 - 0.068	11	0.08
TFE 15 MK (2RS) (2)	15	0 ± -0.008	0 ± -0.12	12	18.4	63	40	10	83	20	34	M14X2	17	44.8	0.040 - 0.082	8	0.14
TFE 17 MK (2RS) (2)	17	0 ± -0.008	0 ± -0.12	14	20.7	69	46	11	92	23	36	M16X2	21.2	56.5	0.040 - 0.082	10	0.19
TFE 20 MK (2RS) (2)	20	0 ± -0.010	0 ± -0.12	16	24.1	78	53	13	104.5	27.5	43	M20X1.5	30	75.6	0.050 - 0.082	9	0.31
TFE 25 MK (2RS)	25	0 ± -0.010	0 ± -0.12	20	29.3	94	64	17	126	32	53	M24X2	48	88.2	0.050 - 0.082	7	0.56
TFE 30 MK (2RS)	30	0 ± -0.010	0 ± -0.12	22	34.2	110	73	19	146.5	37	65	M30X2	62	119	0.050 - 0.100	6	0.89
TFE 35 MK (2RS)	35	0 ± -0.012	0 ± -0.12	25	39.7	140	82	21	181	43	82	M36X3	80	159	0.060 - 0.100	6	1.40
TFE 40 MK (2RS)	40	0 ± -0.012	0 ± -0.12	28	45	150	92	23	196	48	86	M39X3	100	194	0.060 - 0.120	7	1.80
TFE 45 MK (2RS)	45	0 ± -0.012	0 ± -0.12	32	50.7	163	102	27	218	52	94	M42X3	127	259	0.060 - 0.120	7	2.60
TFE 50 MK (2RS)	50	0 ± -0.012	0 ± -0.12	35	56	185	112	30	241	60	106	M45X3	156	313	0.060 - 0.120	6	3.40
TFE 60 MK (2RS)	60	0 ± -0.015	0 ± -0.15	44	66.8	210	135	38	277.5	75	115	M52X3	245	485	0.072 - 0.120	6	5.90
TFE 70 MK (2RS)	70	0 ± -0.015	0 ± -0.15	49	77.8	235	160	42	315	87	125	M56X4	315	564	0.072 - 0.142	6	8.20
TFE 80 MK (2RS)	80	0 ± -0.015	0 ± -0.15	55	89.4	270	180	47	360	100	140	M64X4	400	689	0.072 - 0.142	6	13.10
VERSIONE CON FILETTO MAGGIORATO HIGHER THREAD VERSION																	
TFE 40 MK (2RS) MAG 40	40	0 ± -0.012	0 ± -0.12	28	45	150	92	23	196	48	86	M42X3	100	180	0.060 - 0.120	7	1.85
TFE 45 MK (2RS) MAG 45	45	0 ± -0.012	0 ± -0.12	32	50.7	163	102	27	218	52	94	M45X3	127	240	0.060 - 0.120	7	2.66
TFE 50 MK (2RS) MAG 50	50	0 ± -0.012	0 ± -0.12	35	56	185	112	30	241	60	106	M52X3	156	290	0.060 - 0.120	6	4.00
TFE 60 MK (2RS) MAG 60	60	0 ± -0.015	0 ± -0.15	44	66.8	210	135	38	277.5	75	115	M60X4	245	450	0.072 - 0.120	6	6.70
TFE 70 MK (2RS) MAG 70	70	0 ± -0.015	0 ± -0.15	49	77.8	235	160	42	315	87	125	M72X4	315	610	0.072 - 0.142	6	8.38
TFE 80 MK (2RS) MAG 80	80	0 ± -0.015	0 ± -0.15	55	89.4	271	180	47	360	100	140	M80X4	400	750	0.072 - 0.142	6	15.00

(1) NON RILUBRIFICABILE.  
 (2) RILUBRIFICABILE MEDIANTE UN FORO DI LUBRIFICAZIONE SULLA TESTA.  
 (3) FORNIBILI ANCHE NELLA VERSIONE CON NODO SFERICO SRC... OPPURE SRL...  
 (\*) NEL CASO DI RICHIESTA CON FILETTATURA SINISTRORSA AGGIUNGERE NEL COD. ART. LA LETTERA "L" ES. **TFIL...** - DISPONIBILITA' E PREZZO A RICHIESTA.

(1) NON LUBRICATING.  
 (2) LUBRICATING BY A LUBRICATION OPENING ON THE HEAD.  
 (3) ALSO AVAILABLE WITH SPHERICAL PLAIN BEARING SRC... OR SRL...  
 (\*) WHEN REQUIRING A LEFT-END THREAD, ADD THE LETTER "L" IN THE ARTICLE CODE (e.g.: Tfil...). AVAILABILITY AND PRICES UPON REQUEST.

**TFI...FKB** (SNODO-BEARING SRB...)  
**TFI...T-2RS** (SNODO-BEARING SRT...2RS)  
**TFI...T-2RS MAG.** (SNODO-BEARING SRT...2RS)  
**(SI...C; SI...TXE-2LS; SIA...TXE-2LS; GIR...UK; GIR...UK-2RS)**

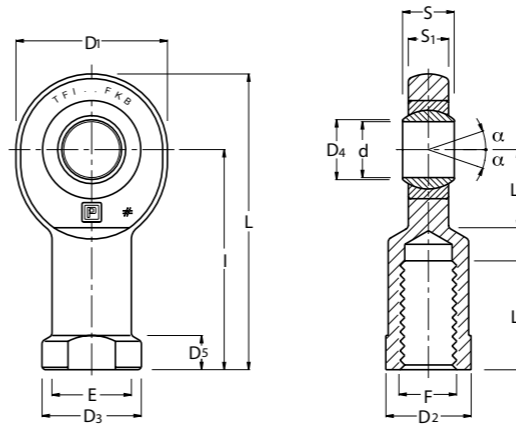

TERMINALI A SNODO  
 ISO 12240-4, SERIE E TIPO F  
 ESENTI DA MANUTENZIONE  
 ACCOPPIAMENTO: ACCIAIO - CROMO DURO SU PTFE  
 TERMINALE IN ACCIAIO C45 ZINCATO  
 ROD ENDS  
 ISO 12240-4, SERIES E TYPE F  
 MAINTENANCE FREE  
 COUPLING: STEEL - HARD CHROMIUM ON PTFE  
 HOUSING MADE OF STEEL C45 ZINC PLATED



SIGLA (*) ARTICLE (*)	d	TOLLERANZE TOLERANCES		S	D4	I	D1	D3	E	D2	D5	S1	L	L1	LF min	F	FATTORI DI CARICO LIMITE LOAD FACTORS		GIUOCO SNODO RADIALE RADIAL CLEARANCE	ANGOLO DI OSCILLAZIONE α SWINGING ANGLE α	PESO IN Kg. WEIGHT Kg.
		d	S														C Dinamico Dynamic	Co Statico Static			
mm.																					
TFI 6 FKB	6	0 ± -0.008	0 ± -0.12	6	8	30	21	13	10.5	11	5	4.3	40.5	10.5	11	M 6X1	3.6	8.1	0 - 0.032	13	0.02
TFI 8 FKB	8	0 ± -0.008	0 ± -0.12	8	10.2	36	24	15	12	13	5	6	48	12	15	M 8X1.25	5.8	12.9	0 - 0.032	15	0.04
TFI 10 FKB	10	0 ± -0.008	0 ± -0.12	9	13.2	43	29	18	15	15	6.5	7	57.5	14	20	M10X1.5	8.6	17.6	0 - 0.032	12	0.06
TFI 12 FKB	12	0 ± -0.008	0 ± -0.12	10	15	50	34	20	17	18	6.5	8	67	17.5	24	M12X1.75	11.4	24.5	0 - 0.032	11	0.09
TFI 15 FKB	15	0 ± -0.008	0 ± -0.12	12	18.4	61	40	24	20	21	8	10	81	20	30	M14X2	17.6	36	0 - 0.040	8	0.18
TFI 17 FKB (F2RS)	17	0 ± -0.008	0 ± -0.12	14	20.7	67	46	28	23	24	10	11	90	23	34	M16X2	22.4	45	0 - 0.040	10	0.22
TFI 20 FKB (F2RS)	20	0 ± -0.010	0 ± -0.12	16	24.1	77	53	35	27.5	32	10	13	103.5	27.5	40	M20X1.5	31.5	60	0 - 0.040	9	0.35
TFI 25 FKB (F2RS)	25	0 ± -0.010	0 ± -0.12	20	29.3	94	64	42	33.5	36	12	17	126	32	48	M24X2	51	83	0 - 0.050	7	0.64
TFI 30 FKB (F2RS)	30	0 ± -0.010	0 ± -0.12	22	34.2	110	73	50	40	41	15	19	146.5	37	56	M30X2	66.5	110	0 - 0.050	6	0.93
TFI 35T-2RS	35	0 ± -0.012	0 ± -0.12	25	39.7	125	82	58	47	50	15	21	166	42	60	M36X3	112	146	0 - 0.050	6	1.30
TFI 40T-2RS	40	0 ± -0.012	0 ± -0.12	28	45	142	92	65	52	55	18	23	188	48	67	M39X3	140	180	0 - 0.060	7	2.01
TFI 45T-2RS	45	0 ± -0.012	0 ± -0.12	32	50.7	145	102	70	58	60	20	27	196	52	65	M42X3	180	240	0 - 0.060	7	2.50
TFI 50T-2RS	50	0 ± -0.012	0 ± -0.12	35	56	160	112	75	62	65	20	30	216	59	69	M45X3	220	290	0 - 0.060	6	3.50
TFI 60T-2RS	60	0 ± -0.015	0 ± -0.15	44	66.8	175	135	88	70	75	20	38	242	75	73	M52X3	345	450	0 - 0.060	6	5.50
TFI 70T-2RS	70	0 ± -0.015	0 ± -0.15	49	77.8	200	160	98	80	85	20	42	280	87	80	M56X4	440	610	0 - 0.072	6	8.60
TFI 80T-2RS	80	0 ± -0.015	0 ± -0.15	55	89.4	230	180	110	95	100	25	47	320	100	85	M64X4	570	695	0 - 0.072	6	12.00
VERSIONE CON FILETTO MAGGIORATO HIGHER THREAD VERSION																					
TFI 40T-2RS MAG	40	0 ± -0.012	0 ± -0.12	28	45	142	92	65	52	55	18	23	188	48	67	M42X3	140	102.5	0 - 0.060	7	1.96
TFI 45T-2RS MAG	45	0 ± -0.012	0 ± -0.12	32	50.7	145	102	70	58	60	20	27	196	52	65	M45X3	180	141	0 - 0.060	7	2.44
TFI 50T-2RS MAG	50	0 ± -0.012	0 ± -0.12	35	56	160	112	75	62	65	20	30	216	59	69	M52X3	220	140	0 - 0.060	6	3.40
TFI 60T-2RS MAG	60	0 ± -0.015	0 ± -0.15	44	66.8	175	135	88	70	75	20	38	242	75	73	M60X4	345	183	0 - 0.060	6	5.38
TFI 70T-2RS MAG	70	0 ± -0.015	0 ± -0.15	49	77.8	200	160	98	85	80	20	42	280	87	80	M72X4	410	306	0 - 0.072	6	8.42
TFI 80T-2RS MAG	80	0 ± -0.015	0 ± -0.15	55	89.4	230	180	110	95	100	25	47	320	100	85	M80X4	570	387	0 - 0.072	6	11.80

FORNIBILI ANCHE NELLA VERSIONE CON NODO SFERICO SRLB..., SRLT-2RS, SR...TGR.  
 (\*) NEL CASO DI RICHIESTA CON FILETTATURA SINISTRORSA AGGIUNGERE NEL COD. ART. LA LETTERA "L" ES. **TFIL...** - DISPONIBILITA' E PREZZO A RICHIESTA.

ALSO AVAILABLE WITH SPHERICAL PLAIN BEARING SRLB..., SRLT...-2RS, SR...TGR.  
 (\*) WHEN REQUIRING A LEFT-END THREAD, ADD THE LETTER "L" IN THE ARTICLE CODE, (e.g.: Tfil...). AVAILABILITY AND PRICES UPON REQUEST.

**TFE...MKB** (SNODO-BEARING SRB...)  
**TFE...T-2RS** (SNODO-BEARING SRT...2RS)  
**TFE...T-2RS MAG.** (SNODO-BEARING SRT...2RS)  
**(SA...C; SA...TXE-2LS; SAA...TXE-2LS; GAR...UK; GAR...UK-2RS)**

TERMINALI A SNODO  
 ISO 12240-4, SERIE E TIPO M  
 ESENTI DA MANUTENZIONE  
 ACCOPPIAMENTO: ACCIAIO - CROMO DURO SU PTFE  
 TERMINALE IN ACCIAIO C45 ZINCATO

ROD ENDS  
 ISO 12240-4, SERIES E TYPE M  
 MAINTENANCE FREE  
 COUPLING: STEEL - HARD CHROMIUM ON PTFE  
 HOUSING MADE OF STEEL C45 ZINC PLATED

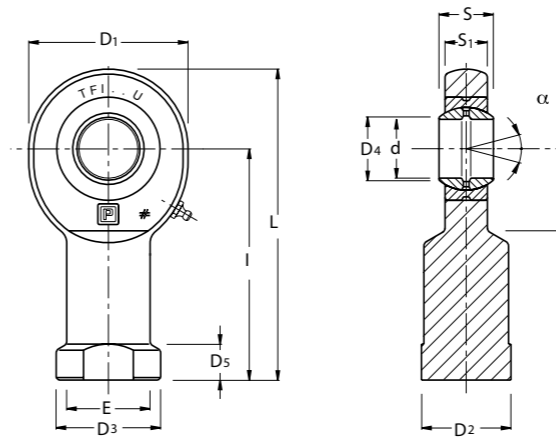
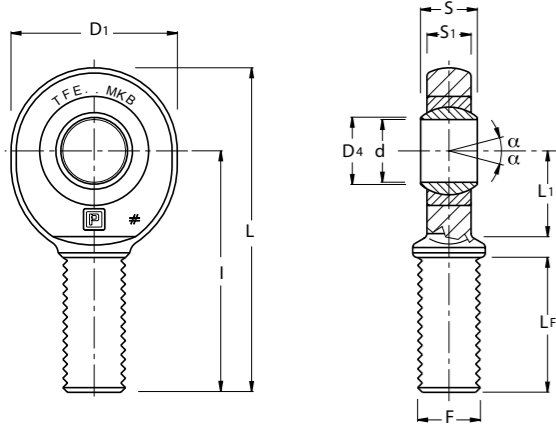

**TFI...U** (SNODO-BEARING SR...)  
 (LUBRIFICABILE) / (WITH GREASE NIPPLE)  
**TFI...UB** (SNODO-BEARING SRB-SRT...-2RS)  
 (ESENTE LUBRIFICAZIONE) / (MAINTENANCE FREE)

TERMINALI A SNODO (SENZA FILETTATURA)  
 ISO 12240-4, SERIE E TIPO F  
 RILUBRIFICABILI / NON RILUBRIFICABILI  
 ACCOPPIAMENTO: ACCIAIO SU ACCIAIO (U)  
 CROMO DURO SU PTFE (UB)  
 TERMINALE IN ACCIAIO C45 ZINCATO  
 ROD ENDS (WITHOUT THREAD)  
 ISO 12240-4, SERIES E TYPE F  
 LUBRICATABLE / NON LUBRICATABLE  
 COUPLING: STEEL/STEEL (U)  
 HARD CHROMIUM ON PTFE (UB)  
 HOUSING MADE OF STEEL C45 ZINC PLATED



SIGLA (*) ARTICLE (*)	TOLLERANZE TOLERANCES		S	D4	I	D1	S1	L	L1	LF min	F	FATTORI DI CARICO LIMITE LOAD FACTORS		GIUOCO SNODO RADIALE RADIAL CLEARANCE	ANGOLO DI OSCILLAZIONE $\alpha$ SWINGING ANGLE $\alpha$	PESO IN Kg. WEIGHT Kg.	
	d	S										C	Co				
	mm.	mm.										KN	mm.				
TFE 6 MKB	6	0 ± -0.008	0 ± -0.12	6	8	36	21	4.3	46.5	12	18	M 6X1	3.6	8.1	0 - 0.032	13	0.01
TFE 8 MKB	8	0 ± -0.008	0 ± -0.12	8	10.2	42	24	6	54	14	22	M 8X1.25	5.8	12.9	0 - 0.032	15	0.03
TFE 10 MKB	10	0 ± -0.008	0 ± -0.12	9	13.2	48	29	7	62.5	15	27	M10X1.5	8.6	17.6	0 - 0.032	12	0.05
TFE 12 MKB	12	0 ± -0.008	0 ± -0.12	10	15	54	34	8	71	19	30	M12X1.75	11.4	24.5	0 - 0.032	11	0.08
TFE 15 MKB	15	0 ± +0.008	0 ± -0.12	12	18.4	63	40	10	83	20	34	M14X2	17.6	36	0 - 0.040	8	0.14
TFE 17 MKB (T-2RS)	17	0 ± -0.008	0 ± -0.12	14	20.7	69	46	11	92	23	36	M16X2	22.4	45	0 - 0.040	10	0.19
TFE 20 MKB (T-2RS)	20	0 ± -0.010	0 ± -0.12	16	24.1	78	53	13	104.5	27.5	43	M20X1.5	31.5	60	0 - 0.040	9	0.31
TFE 25 MKB (T-2RS)	25	0 ± -0.010	0 ± -0.12	20	29.3	94	64	17	126	33	53	M24X2	51	83	0 - 0.050	7	0.56
TFE 30 MKB (T-2RS)	30	0 ± -0.010	0 ± -0.12	22	34.2	110	73	19	146.5	37	65	M30X2	65.5	110	0 - 0.050	6	0.89
TFE 35 T-2RS	35	0 ± -0.012	0 ± -0.12	25	39.7	140	82	21	181	43	82	M36X3	112	146	0 - 0.050	6	1.40
TFE 40 T-2RS	40	0 ± -0.012	0 ± -0.12	28	45	150	92	23	196	48	86	M39X3	140	180	0 - 0.060	7	1.80
TFE 45 T-2RS	45	0 ± -0.012	0 ± -0.12	32	50.7	163	102	27	218	52	94	M42X3	180	240	0 - 0.060	7	2.60
TFE 50 T-2RS	50	0 ± -0.012	0 ± -0.12	35	56	185	112	30	241	60	106	M45X3	220	290	0 - 0.060	6	3.40
TFE 60 T-2RS	60	0 ± -0.015	0 ± -0.15	44	66.8	210	135	38	277.5	75	115	M52X3	345	450	0 - 0.060	6	5.90
TFE 70 T-2RS	70	0 ± -0.015	0 ± -0.15	49	77.8	235	160	42	315	87	125	M56X4	440	610	0 - 0.072	6	8.20
TFE 80 T-2RS	80	0 ± -0.015	0 ± -0.15	55	89.4	270	180	47	360	100	140	M64X4	570	750	0 - 0.072	6	12.00
VERSIONE CON FILETTO MAGGIORATO HIGHER THREAD VERSION																	
TFE 40 T-2RS MAG	40	0 ± -0.012	0 ± -0.12	8	45	150	92	23	196	48	86	M42X3	140	180	0 - 0.060	7	1.85
TFE 45 T-2RS MAG	45	0 ± -0.012	0 ± -0.12	32	50.7	163	102	27	218	52	94	M45X3	180	240	0 - 0.060	7	2.66
TFE 50 T-2RS MAG	50	0 ± -0.012	0 ± -0.12	35	56	185	112	30	241	60	106	M45X3	220	290	0 - 0.060	6	3.50
TFE 60 T-2RS MAG	60	0 ± -0.015	0 ± -0.15	44	66.8	210	135	38	277.5	75	115	M60X4	345	450	0 - 0.060	6	6.02
TFE 70 T-2RS MAG	70	0 ± -0.015	0 ± -0.15	49	77.8	235	160	42	315	87	125	M72X4	440	610	0 - 0.072	6	8.38
TFE 80 T-2RS MAG	80	0 ± -0.015	0 ± -0.15	55	89.4	270	180	47	360	100	140	M80X4	570	750	0 - 0.072	6	12.20

FORNIBILI ANCHE NELLA VERSIONE CON NODO SFERICO SRLB..., SRLT...-2RS, SR...TGR.  
 (\*) NEL CASO DI RICHIESTA CON FILETTATURA SINISTRORSA AGGIUNGERE NEL COD. ART. LA LETTERA "L" ES.TFEL... - DISPONIBILITA' E PREZZO A RICHIESTA.

ALSO AVAILABLE WITH SPHERICAL PLAIN BEARING SRLB..., SRLT...-2RS, SR...TGR.  
 (\*) WHEN REQUIRING A LEFT-END THREAD, ADD THE LETTER "L" IN THE ARTICLE CODE, (e.g.: TFEL...). AVAILABILITY AND PRICES UPON REQUEST.

SIGLA (*) ARTICLE (*)	TOLLERANZE TOLERANCES		S	D4	I	D1	D3	E	D2	D5	S1	L	L1	FATTORI DI CARICO LIMITE LOAD FACTORS		GIUOCO SNODO RADIALE RADIAL CLEARANCE	ANGOLO DI OSCILLAZIONE $\alpha$ SWINGING ANGLE $\alpha$	PESO IN Kg. WEIGHT Kg.	
	d	S												C	Co				
	mm.	mm.												KN	mm.				
TFI 6 U/UB	6	0 ± -0.008	0 ± -0.12	6	8	30	21	13	10.5	11	5	4.3	40.5	10.5	3.4	8.1	0.032 - 0.068	13	0.02
TFI 8 U/UB	8	0 ± -0.008	0 ± -0.12	8	10.2	36	24	15	12.5	13	5	6	48	12	5.5	12.9	0.032 - 0.068	15	0.04
TFI 10 U/UB	10	0 ± -0.008	0 ± -0.12	9	13.2	43	29	18	15	15	6.5	7	57.5	14	8.1	17.6	0.032 - 0.068	12	0.07
TFI 12 U/UB	12	0 ± -0.008	0 ± -0.12	10	15	50	34	20	17	18	6.5	8	67	17.5	10.8	24.5	0.040 - 0.068	11	0.13
TFI 15 U/UB (2RS)	15	0 ± -0.008	0 ± -0.12	12	18.4	61	40	24	20	21	8	10	81	20	17	36	0.040 - 0.082	8	0.22
TFI 17 U/UB (2RS)	17	0 ± -0.008	0 ± -0.12	14	20.7	67	46	28	23	24	10	11	90	23	21.2	45	0.040 - 0.082	10	0.30
TFI 20 U/UB (2RS)	20	0 ± -0.010	0 ± -0.12	16	24.1	77	53	35	27.5	32	10	13	103.5	27.5	30	60	0.050 - 0.082	9	0.46
TFI 25 U/UB (2RS)	25	0 ± -0.010	0 ± -0.12	20	29.3	94	64	42	33.5	36	12	17	126	32	48	83	0.050 - 0.100	7	0.81
TFI 30 U/UB (2RS)	30	0 ± -0.010	0 ± -0.12	22	34.2	110	73	50	40	41	15	19	146.5	37	62	110	0.050 - 0.100	6	1.20
TFI 35 U/UB (2RS)	35	0 ± -0.012	0 ± -0.12	25	39.7	125	82	58	47	50	15	21	166	42	80	146	0.060 - 0.100	6	1.90
TFI 40 U/UB (2RS)	40	0 ± -0.012	0 ± -0.12	28	45	142	92	65	52	55	18	23	188	48	100	180	0.060 - 0.120	7	2.70
TFI 45 U/UB (2RS)	45	0 ± -0.012	0 ± -0.12	32	50.7	145	102	70	58	60	20	27	196	52	127	240	0.060 - 0.120	7	3.80
TFI 50 U/UB (2RS)	50	0 ± -0.012	0 ± -0.12	35	56	160	112	75	62	65	20	30	216	59	156	290	0.060 - 0.120	6	5.00
TFI 60 U/UB (2RS)	60	0 ± -0.015	0 ± -0.15	44	66.8	175	135	88	70	75	20	38	242	75	245	450	0.072 - 0.120	6	7.30
TFI 70 U/UB (2RS)	70	0 ± -0.015	0 ± -0.15	49	77.8	200	160	98	80	85	20	42	280	87	315	610	0.072 - 0.142	6	11.40
TFI 80 U/UB (2RS)	80	0 ± -0.015	0 ± -0.15	55	89.4	230	180	110	95	100	25	47	320	100	400	750	0.072 - 0.142	6	16.10

(1) GIOCO RADIALE SNODO PER TFI...U.  
 (2) FORNIBILI ANCHE CON SNODO SFERICO SRC..., SRL... PER TFI...U OPPURE SRLB..., SRLT...2RS, SR...TGR PER TFI... UB.

(1) RADIAL CLEARANCE BEARING FOR TFI...U.  
 (2) ALSO AVAILABLE WITH SPHERICAL PLAIN BEARING SRC..., SRL... FOR TFI...U OR SRLB..., SRLT...2RS, SR...TGR PER TFI... UB.



**TERMINALI A SNODO PER APPLICAZIONI AGRICOLE**  
**AGRICULTURAL BALL JOINT TERMINALS**

TERMINALE A SNODO SFERICO AD ESTREMITA' RETTANGOLARE - FIANCHI DIRITTI  
ACCOPPIAMENTO ACCIAIO SU ACCIAIO - CORPO IN ACCIAIO C 40 UNI EN 10083-1

BALL JOINT TERMINAL WITH RECTANGULAR END  
COUPLING STEEL ON STEEL - ROD END OF STEEL C 40 UNI EN 10083-1

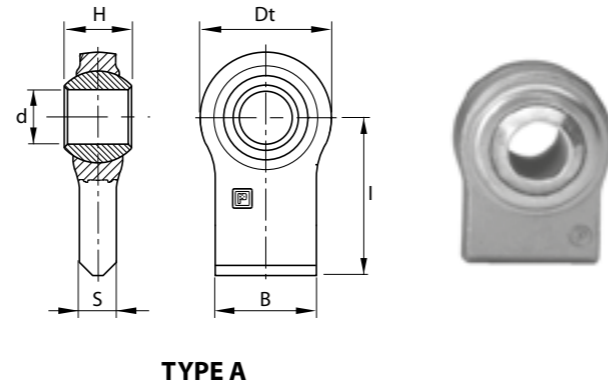

**TYPE A**

SIGLA ARTICLE	CAT.	d (A12)	H (h11)	B	S	Dt	I	TYPE	PESO IN Kg. WEIGHT Kg.
SR 10490	-	14	32	30	11	46	60	A	0.30
SR 10495	-	16	20	30	11	46	60	A	0.27
SR 10496	-	19	44	52	17	52	50	A	0.46
SR 10494	-	18	35	50	15	65	43	A	0.58
SR 10497	-	19	35	50	15	65	43	A	0.56
SR 10498	1	22.1	35	50	15	65	43	A	0.54
SR 10501	1	22.1	35	50	15	68	90	A	0.92
SR 10503	1	22.1	35	55	15	66	70	A	0.70
SR 10506	-	25.4	38	70	18	78	80	A	1.14
SR 10507	2	28.4	38	70	18	78	80	A	1.10
SR 10510	1	22.1	35	70	18	76	50	A	0.82
SR 10515	-	25.4	35	70	18	76	50	A	0.78
SR 10520	-	26	35	70	18	76	50	A	0.78
SR 10530	2	28.4	35	70	18	76	50	A	0.76
SR 10540	1	22.1	35	70	19	83	55	A	1.18
SR 10550	-	25.4	35	70	19	83	55	A	1.16
SR 10560	2	28.4	35	70	19	83	55	A	1.12
SR 10562	2	28.4	45	70	19	83	55	A	1.16
SR 10564	2	28.4	45	70	20	82	55	A	1.22
SR 10566	-	25.4	38	70	23	80	80	A	1.56
SR 10568	2	28.4	38	70	23	80	80	A	1.52
SR 10575	2	28.4	45	70	23	80	80	A	1.54
SR 10569	-	25.4	45	70	22	80	65	A	1.36
SR 10570	2	28.4	45	70	22	80	65	A	1.32
SR 10590	1/2	22.1/28.4	45	70	22	80	65	A	1.22
SR 10579	2	28.4	45	76	17	90	82	A	1.48
SR 10580	2	28.4	45	70	22	96	65	A	1.70
SR 10597	-	32	45	70	22	96	65	A	1.66
SR 10600	-	34	45	70	22	96	65	A	1.62
SR 10602	-	35	45	70	22	96	65	A	1.60
SR 10604	3	37	45	70	22	96	65	A	1.56
SR 10610	-	38	45	80	24	108	65	A	1.96
SR 10612	-	34	45	80	24	108	65	A	2.04
SR 10614	3	37	45	80	24	108	65	A	1.98
SR 10615	2	28.4	45	80	24	108	65	A	2.16
SR 10616	-	35	45	80	24	108	65	A	2.00
SR 10617	-	42	45	80	24	108	65	A	1.88

TERMINALE A SNODO SFERICO AD ESTREMITA' RETTANGOLARE - FIANCHI DIRITTI  
ACCOPPIAMENTO ACCIAIO SU ACCIAIO - CORPO IN ACCIAIO C 40 UNI EN 10083-1

BALL JOINT TERMINAL WITH RECTANGULAR END  
COUPLING STEEL ON STEEL - ROD END OF STEEL C 40 UNI EN 10083-1

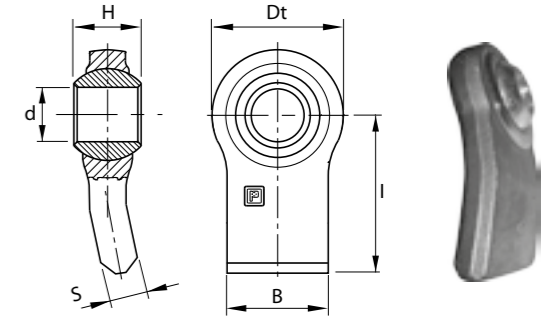

**TYPE B**

SIGLA ARTICLE	CAT.	d (A12)	H (h11)	B	S	Dt	I	TYPE	PESO IN Kg. WEIGHT Kg.
SR 10508	1	22.1	35	60	15	68	90	B	0.98
SR 10585	2	28.4	45	70	21	83	110	B	1.84
SR 10636	2	28.4	45	94	30	94	91	B	2.58
SR 10637	-	38	45	94	30	94	91	B	2.38

TERMINALE A SNODO SFERICO PER BRACCI INFERIORI - FIANCHI INCLINATI  
ACCOPPIAMENTO ACCIAIO SU ACCIAIO CORPO IN ACCIAIO C 40 UNI EN 10083-1

WELD ON BALL ENDS  
COUPLING STEEL ON STEEL - ROD END OF STEEL C 40 UNI EN 10083-1

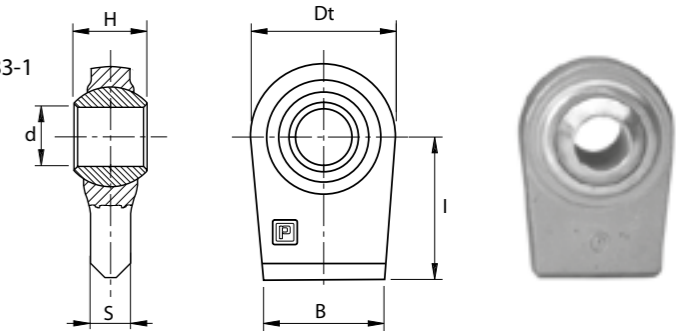

SIGLA ARTICLE	CAT.	d (A12)	H (h11)	B	S	Dt	I	PESO IN Kg. WEIGHT Kg.
SR 10499	-	19	35	60	18	67	50	0.74
SR 10500	1	22.1	35	60	18	67	50	0.72
SR 10505	1	22.1	35	58	18	67	75	0.94
SR 10576	2	28.4	45	70	18	85	80	1.44
SR 10577	1/2	22.1/28.4	45	70	18	85	80	1.34
SR 10578	2	28.4	35	70	18	85	80	1.40

TERMINALE A SNODO SFERICO CON FONDELLO  
PER CILINDRI IDRAULICI A SALDARE  
ACCOPPIAMENTO ACCIAIO SU ACCIAIO  
CORPO IN ACCIAIO C40 UNI EN 10083-1

BALL JOINT TERMINAL WITH BULKHEAD TO BE WELDED  
COUPLING STEEL ON STEEL ROD END OF STEEL C 40 UNI EN 10083-1

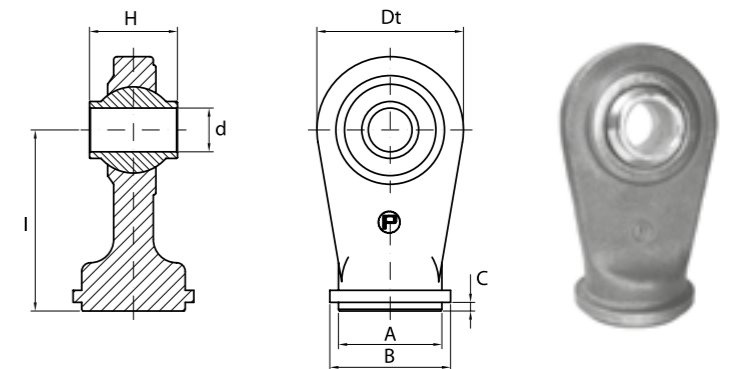

SIGLA ARTICLE	d (A12)	H (h11)	A (Ø)	B (Ø)	C	Dt	I	NOTE NOTE	PESO IN Kg. WEIGHT Kg.
SR 106025	25,4	51	60	70	5	85	105	BASE SPIANATA-FLAT BASE	2,25
SR 106325	25,4	51	63	73	5	85	105	BASE SPIANATA-FLAT BASE	2,28
SR 107025	25,4	51	70	80	5	85	105	BASE SPIANATA-FLAT BASE	2,36

TERMINALE A SNODO SFERICO AD ESTREMITA' ROTONDA  
PER CILINDRI IDRAULICI DA SALDARE  
ACCOPIAMENTO ACCIAIO SU ACCIAIO CORPO IN ACCIAIO C 40 UNI EN 10083-1

BALL JOINT TERMINAL WITH ROUND END TO BE WELDED  
COUPLING STEEL ON STEEL  
ROD END OF STEEL C 40 UNI EN 10083-1

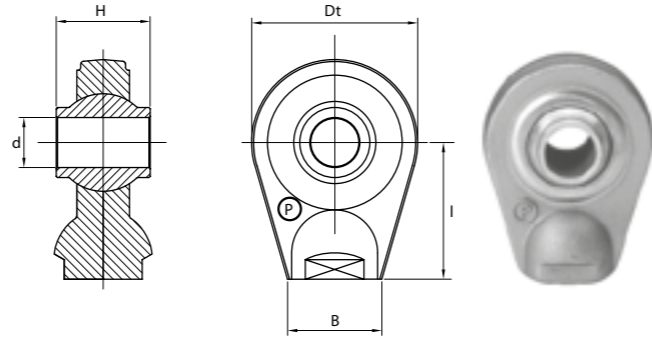

SIGLA ARTICLE	CAT.	d (A12)	H (h11)	B (Ø)	Dt	l	Df	Pf	NOTE NOTE	PESO IN Kg. WEIGHT Kg.
SR 10705	1	19	44	30	62	50	-	-	BASE SPIANATA-FLAT BASE	0.54
SR 10707	-	22.1	44	34	62	58	-	-	BASE SPIANATA-FLAT BASE	0.58
SR 10708	1	19	44	34	62	58	-	-	BASE SPIANATA-FLAT BASE	0.60
SR 10709	-	20	44	34	62	58	-	-	BASE SPIANATA-FLAT BASE	0.59
SR 10710	1	19	44	34	62	60	-	-	BASE SPIANATA-FLAT BASE	0.62
SR 10712	-	22.1	44	34	62	60	-	-	BASE SPIANATA-FLAT BASE	0.60
SR 10720	-	20	44	34	62	60	-	-	BASE SPIANATA-FLAT BASE	0.61
SR 10724	1	19	35	26	62	50	-	-	BASE SPIANATA-FLAT BASE	0.54
SR 10725	-	22.1	35	26	62	50	-	-	BASE SPIANATA-FLAT BASE	0.52
SR 10727	1	19	35	30	70	46	-	-	BASE SPIANATA-FLAT BASE	0.64
SR 10730	-	22.1	51	38	75	65	-	-	BASE SPIANATA-FLAT BASE	0.98
SR 10735	2	25.4	40	38	75	65	-	-	BASE SPIANATA-FLAT BASE	0.90
SR 10737	1	19	51	38	75	65	-	-	BASE SPIANATA-FLAT BASE	1.02
SR 10739	-	30	51	38	75	65	-	-	BASE SPIANATA-FLAT BASE	0.88
SR 10740	2	25.4	51	38	75	65	-	-	BASE SPIANATA-FLAT BASE	0.94
SR 10741	2	25.4	51	31	75	70	-	-	BASE SPIANATA-FLAT BASE	0.90
SR 10742	2	25.4	51	45	72	70	-	-	BASE SPIANATA-FLAT BASE	1.14
SR 10744	1	19	51	45	72	70	-	-	BASE SPIANATA-FLAT BASE	1.22
SR 10746	-	22.1	51	45	72	70	-	-	BASE SPIANATA-FLAT BASE	1.18
SR 10748	-	30	51	45	72	70	-	-	BASE SPIANATA-FLAT BASE	1.08
SR 10756	-	22.1	51	50	85	70	-	-	BASE SPIANATA-FLAT BASE	1.64
SR 10759	1	19	51	50	85	70	-	-	BASE SPIANATA-FLAT BASE	1.68
SR 10760	2	25.4	51	50	85	70	-	-	BASE SPIANATA-FLAT BASE	1.62
SR 10780	-	30	51	50	85	70	-	-	BASE SPIANATA-FLAT BASE	1.56
SR 10791	2	25.4	51	40	90	85	-	-	BASE SPIANATA-FLAT BASE	1.68
SR 10792	-	30	51	40	90	85	-	-	BASE SPIANATA-FLAT BASE	1.64
SR 10793	3	32	51	40	90	85	-	-	BASE SPIANATA-FLAT BASE	1.58
SR 10795	-	35	55	40	90	85	-	-	BASE SPIANATA-FLAT BASE	1.52
SR 10796	1/2	19/25.4	45X45	40	90	85	-	-	BASE SPIANATA-FLAT BASE	1.56
SR 10750	2	25.4	51	50	83	65	-	-	BASE SPIANATA-FLAT BASE	1.38
SR 10800	-	29	55	50	83	65	-	-	BASE SPIANATA-FLAT BASE	1.38
SR 10805	-	30	42	50	83	65	-	-	BASE SPIANATA-FLAT BASE	1.30
SR 10807	3	32	51	50	83	65	-	-	BASE SPIANATA-FLAT BASE	1.30
SR 10810	-	30	55	50	83	65	-	-	BASE SPIANATA-FLAT BASE	1.36
SR 10812	-	35	35	50	83	65	-	-	BASE SPIANATA-FLAT BASE	1.20
SR 10815	-	35	55	50	83	65	-	-	BASE SPIANATA-FLAT BASE	1.24
SR 10816	-	29	55	50	92	65	-	-	BASE SPIANATA-FLAT BASE	1.60
SR 10817	-	30	55	50	92	65	-	-	BASE SPIANATA-FLAT BASE	1.58
SR 10818	-	30	42	50	92	65	-	-	BASE SPIANATA-FLAT BASE	1.52
SR 10825	3	32	51	50	92	65	-	-	BASE SPIANATA-FLAT BASE	1.54
SR 10819	-	35	35	50	92	65	-	-	BASE SPIANATA-FLAT BASE	1.42
SR10821	-	40	75	58	108	60	-	-	BASE SPIANATA-FLAT BASE	2.76
SR 10841	-	45	75	58	108	60	-	-	BASE SPIANATA-FLAT BASE	2.56
SR 10861	-	50	75	58	108	60	-	-	BASE SPIANATA-FLAT BASE	2.36
SR 10820	-	40	75	60	108	85	-	-	BASE SPIANATA-FLAT BASE	3.42
SR 10840	-	45	75	60	108	85	-	-	BASE SPIANATA-FLAT BASE	3.22
SR 10860	-	50	75	60	108	85	-	-	BASE SPIANATA-FLAT BASE	3.02

A RICHIESTA FORO (d) RETTIFICATO  
RECTIFIED HOLE (d) REQUEST

TERMINALE A SNODO SFERICO AD ESTREMITA' ROTONDA  
PER CILINDRI IDRAULICI DA SALDARE  
ACCOPIAMENTO ACCIAIO SU ACCIAIO CORPO IN ACCIAIO C 40 UNI EN 10083-1  
BALL JOINT TERMINAL WITH ROUND END TO BE WELDED  
COUPLING STEEL ON STEEL  
ROD END OF STEEL C 40 UNI EN 10083-1

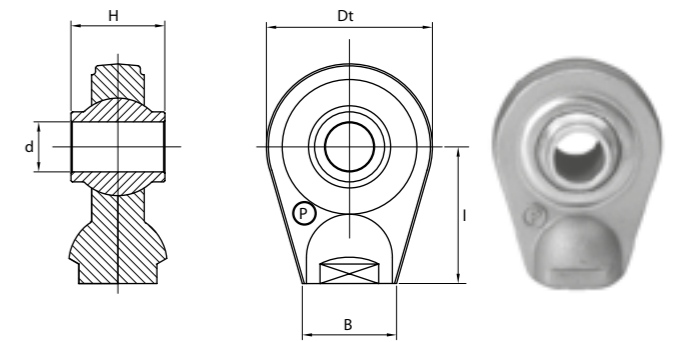

SIGLA ARTICLE	CAT.	d (A12)	H (h11)	B (Ø)	Dt	l	Df	Pf	NOTE NOTE	PESO IN Kg. WEIGHT Kg.
SR 10693	-	14	44	25	55	50	-	-	BASE GREZZA-ROUGH BASE	0.46
SR 10694	1	19	30	25	55	50	-	-	BASE GREZZA-ROUGH BASE	0.40
SR 10695	1	19	44	25	55	50	-	-	BASE GREZZA-ROUGH BASE	0.42
SR 10696	-	20	44	25	55	50	-	-	BASE GREZZA-ROUGH BASE	0.41
SR 10697	1	19	44	26	55	65	-	-	BASE GREZZA-ROUGH BASE	0.50

A RICHIESTA FORO (d) RETTIFICATO  
RECTIFIED HOLE (d) REQUEST

TERMINALE A SNODO SFERICO AD ESTREMITA' ROTONDA  
PER CILINDRI IDRAULICI CON FILETTATURA INTERNA  
ACCOPIAMENTO ACCIAIO SU ACCIAIO CORPO IN ACCIAIO C 40 UNI EN 10083-1  
BALL JOINT TERMINAL WITH ROUND END  
WITH INNER THREAD COUPLING STEEL ON STEEL  
ROD END OF STEEL C 40 UNI EN 10083-1

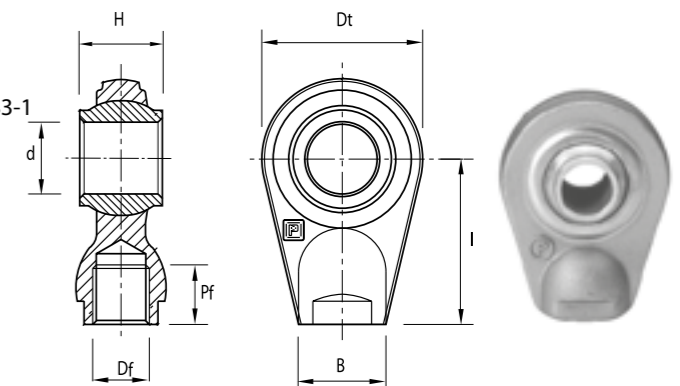

SIGLA ARTICLE	CAT.	d (A12)	H (h11)	B (Ø)	Dt	l	Df	Pf	NOTE NOTE	PESO IN Kg. WEIGHT Kg.
SR 10768	-	22.1	51	50	85	70	M27X2	27	BASE SPIANATA-FLAT BASE	1.50
SR 10769	1	19	51	50	85	70	M27X2	27	BASE SPIANATA-FLAT BASE	1.54
SR 10770	2	25.4	51	50	85	70	M27X2	27	BASE SPIANATA-FLAT BASE	1.46
SR 10790	-	30	51	50	85	70	M27X2	27	BASE SPIANATA-FLAT BASE	1.40
SR 10794	3	32	51	40	90	85	M27X2	27	BASE SPIANATA-FLAT BASE	1.44
SR 10830	-	40	75	60	108	85	M38X2	28	BASE SPIANATA-FLAT BASE	3.10
SR 10850	-	45	75	60	108	85	M38X2	28	BASE SPIANATA-FLAT BASE	2.90
SR 10870	-	50	75	60	108	85	M38X2	28	BASE SPIANATA-FLAT BASE	2.70

A RICHIESTA FORO (d) RETTIFICATO  
RECTIFIED HOLE (d) REQUEST

TERMINALE A SNODO SFERICO A BASE RETTANGOLARE  
PER CILINDRI IDRAULICI DA SALDARE  
ACCOPIAMENTO ACCIAIO SU ACCIAIO CORPO IN ACCIAIO C 40 UNI EN 10083-1  
BALL JOINT TERMINAL WITH RECTANGULAR END TO BE WELDED  
COUPLING STEEL ON STEEL  
ROD END OF STEEL C 40 UNI EN 10083-1

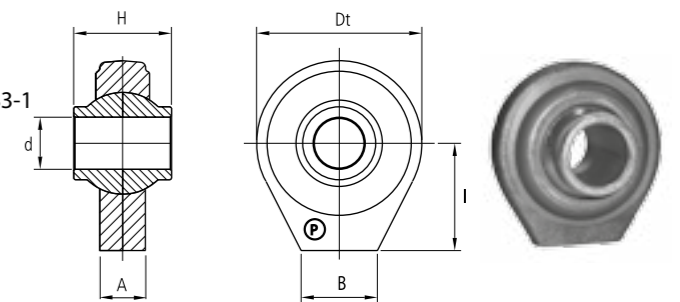

SIGLA ARTICLE	CAT.	d (A12)	H (h11)	BxA	Dt	l	Df	Pf	NOTE NOTE	PESO IN Kg. WEIGHT Kg.
SR 10700	1	19	44	30X13	62	34	-	-	BASE GREZZA-ROUGH BASE	0.44
SR 10702	-	20	44	30X13	62	34	-	-	BASE GREZZA-ROUGH BASE	0.43
SR 10704	-	22.1	44	30X13	62	34	-	-	BASE GREZZA-ROUGH BASE	0.42

A RICHIESTA FORO (d) RETTIFICATO  
RECTIFIED HOLE (d) REQUEST

TERMINALE A SNODO SFERICO AD ESTREMITA' ROTONDA  
PER CILINDRI IDRAULICI DA SALDARE  
ACCOPIAMENTO ACCIAIO SU ACCIAIO  
CORPO IN ACCIAIO C 40 UNI EN 10083-1  
BALL JOINT TERMINAL WITH ROUND END TO BE WELDED  
COUPLING STEEL ON STEEL  
ROD END OF STEEL C 40 UNI EN 10083-1

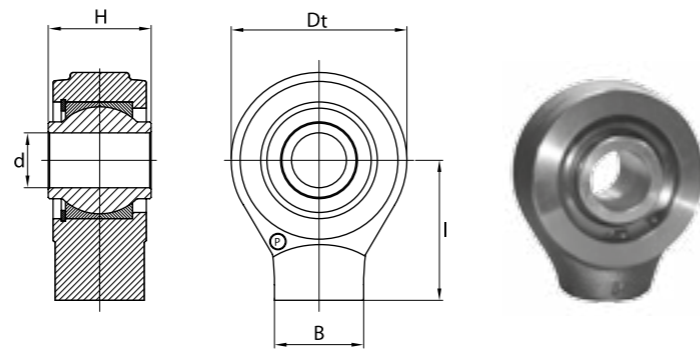

(\*) CON DUE SEDI RIPORTATE REGISTRABILI  
(\*) WITH TWO SEATINGS TRANSFERRED ADJUSTABLE

SIGLA ARTICLE	CAT.	d (A12)	H (h11)	B (Ø)	Dt	I	Df	Pf	NOTE NOTE	PESO IN Kg. WEIGHT Kg.
SR 10871 (*)	-	40	75	65	128	85	-	-	BASE SPIANATA-FLAT BASE	6.38
SR 10872 (*)	-	45	75	65	128	85	-	-	BASE SPIANATA-FLAT BASE	6.18
SR 10873 (*)	-	50	75	65	128	85	-	-	BASE SPIANATA-FLAT BASE	5.98

A RICHIESTA FORO (d) RETTIFICATO  
RECTIFIED HOLE (d) REQUEST

TERMINALE A SNODO SFERICO AD ESTREMITA' ROTONDA  
PER CILINDRI IDRAULICI CON FILETTATURA INTERNA  
ACCOPIAMENTO ACCIAIO SU ACCIAIO  
CORPO IN ACCIAIO C 40 UNI EN 10083-1

BALL JOINT TERMINAL WITH ROUND END  
WITH INNER THREAD COUPLING STEEL ON STEEL  
ROD END OF STEEL C 40 UNI EN 10083-1

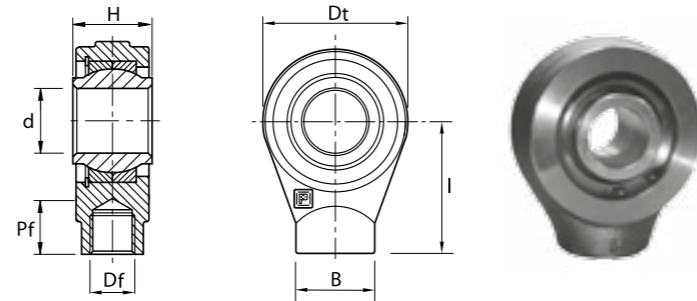

(\*) CON DUE SEDI RIPORTATE REGISTRABILI  
(\*) WITH TWO SEATINGS TRANSFERRED ADJUSTABLE

SIGLA ARTICLE	CAT.	d (A12)	H (h11)	B (Ø)	Dt	I	Df	Pf	NOTE NOTE	PESO IN Kg. WEIGHT Kg.
SR 10874 (*)	-	40	75	65	128	85	M38X2	28	BASE SPIANATA-FLAT BASE	6.16
SR 10875 (*)	-	45	75	65	128	85	M38X2	28	BASE SPIANATA-FLAT BASE	5.96
SR 10876 (*)	-	50	75	65	128	85	M38X2	28	BASE SPIANATA-FLAT BASE	5.76

A RICHIESTA FORO (d) RETTIFICATO  
RECTIFIED HOLE (d) REQUEST

TERMINALE A SNODO SFERICO AD ESTREMITA' ROTONDA  
PER CILINDRI IDRAULICI DA SALDARE  
ACCOPIAMENTO ACCIAIO SU ACCIAIO  
CORPO IN ACCIAIO C 40 UNI EN 10083-1  
BALL JOINT TERMINAL WITH ROUND END TO BE WELDED  
COUPLING STEEL ON STEEL  
ROD END OF STEEL C 40 UNI EN 10083-1

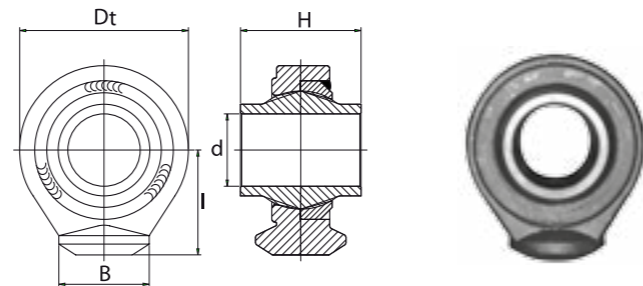

SIGLA ARTICLE	CAT.	d (A12)	H (h11)	B (Ø)	Dt	I	Df	Pf	NOTE NOTE	PESO IN Kg. WEIGHT Kg.
SR 10880	-	60 (H7)	100	75	140	87	-	-	BASE SPIANATA-FLAT BASE	5.66

TERMINALE A SNODO SFERICO AD ESTREMITA' ROTONDA  
PER CILINDRI IDRAULICI DA SALDARE  
ACCOPIAMENTO ACCIAIO SU ACCIAIO  
CORPO IN ACCIAIO C 40 UNI EN 10083-1

BALL JOINT TERMINAL WITH ROUND END TO BE WELDED.  
COUPLING STEEL ON STEEL - ROD END OF STEEL C 40 UNI EN 10083-1

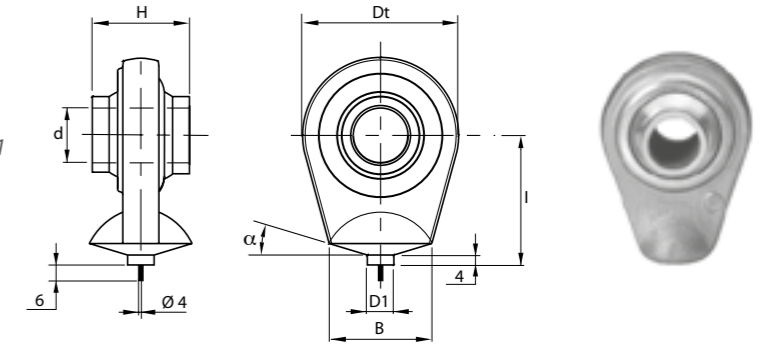

SIGLA ARTICLE	CAT.	d (A12)	H (h11)	B (Ø)	Dt	I	D1	GRADI DEGREE α	PESO IN Kg. WEIGHT Kg.
SR 10731	1	19	51	35	75	55	12	15	0.88
SR 10732	-	22.1	51	35	75	55	12	15	0.87
SR 10736	2	25.4	51	35	75	55	12	15	0.84
SR 10733	-	28.4	51	35	75	55	12	15	0.82
SR 10738	-	30	51	35	75	55	12	15	0.78
SR 10808	-	30	55	45	83	65	20	20	1.50
SR 10811	3	32	51	45	83	65	20	20	1.40
SR 10814	-	35	55	45	83	65	20	20	1.42

TERMINALE CON SNODO SFERICO SMONTABILE  
ACCOPIAMENTO ACCIAIO SU ACCIAIO CORPO IN ACCIAIO C 40 UNI EN 10083-1  
HOUSING WITH DISMOUNTABLE BALL JOINT  
COUPLING STEEL ON STEEL - ROD END OF STEEL C 40 UNI EN 10083-1

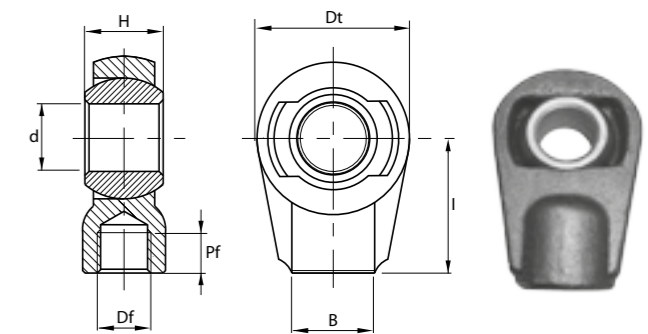

A RICHIESTA SI ESEGUONO FILETTATURE SPECIALI  
ON YOUR REQUEST WE MAKE CUSTOMISED THREADING

SIGLA ARTICLE	d (H10)	H (h11)	B (Ø)	Dt	I	Df	Pf	NOTE NOTE	PESO IN Kg. WEIGHT Kg.
SR 10900	16	20	27	44	45	M16X1.5	20	BASE SPIANATA-FLAT BASE	0.28
SR 10910	20	20	27	44	45	M18X1.5	20	BASE SPIANATA-FLAT BASE	0.25
SR 10920	25	30	35	61	60	M20X1.5	25	BASE SPIANATA-FLAT BASE	0.80
SR 10930	30	30	35	61	60	M22X1.5	25	BASE SPIANATA-FLAT BASE	0.72
SR 10940	35	40	45	80	80	M27X2	35	BASE SPIANATA-FLAT BASE	1.70
SR 10950	40	40	45	80	80	M30X2	35	BASE SPIANATA-FLAT BASE	1.60

**BASI OSCILLANTI**  
**SWINGING ENDS**

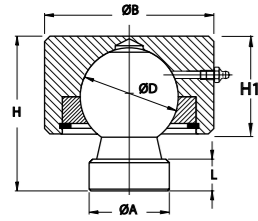

**BO...**

BASE OSCILLANTE  
SWINGING END



SIGLA ARTICLE	ØD	ØA	ØB	H	H1	L	CARICO LIMITE LOAD FACTORS	α	PESO IN Kg. WEIGHT Kg.
BO 1803	50	40	85	82	45	20	9.60	38	2.20
BO 1804	60	50	98	100	50	25	15.70	40	3.40
BO 1805	70	60	105	115	60	30	18.90	38	4.82

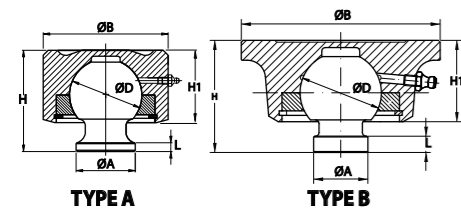

**BO...**

BASE OSCILLANTE  
SWINGING END

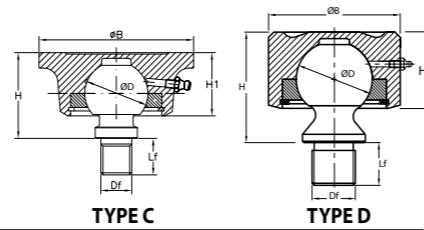

SIGLA ARTICLE	ØD	ØA	ØB	H	H1	L	Df	Lf	CARICO LIMITE LOAD FACTORS	TYPE	α	PESO IN Kg. WEIGHT Kg.
BO 1980	45	30	110	62	45	9	-	-	11.0	B	35	2.20
BO 1982	55	45	95	78	55	8	-	-	15.0	A	30	2.88
BO 1984	65	64	107	88	58	9	-	-	23.0	A	30	3.96
BO 1986	45	30	110	61	45	-	M22X1.5	26	11.0	C	32	2.28
BO 1988	55	45	95	78	55	-	M32X2	35	15.0	D	30	3.10

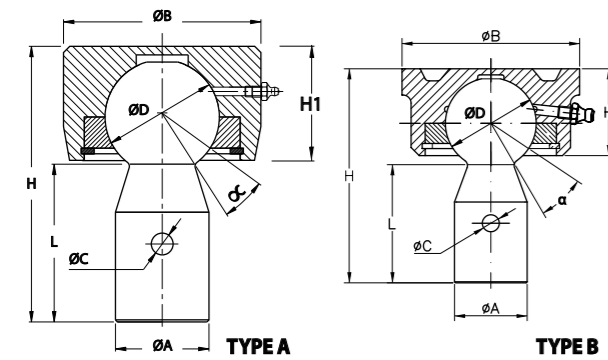

**BO...**

BASE OSCILLANTE  
SWINGING END



SIGLA ARTICLE	ØD	ØA	ØB	ØC	H	H1	L	CARICO LIMITE LOAD FACTORS	TYPE	α	PESO IN Kg. WEIGHT Kg.
BO 1700 (1)	45	36	88	-	106	43	64	8.0	B	22	2.18
BO 1701 (1)	45	36	88	8.4	106	43	58.5	8.0	B	36	2.40
BO 1702 (1)	55	36	92	8.4	118.5	53.5	62	14.0	A	33	3.10

(1) L'INGRASSATORE È INCLINATO DI CIRCA 6° PER FAVORIRE L'INGRASSAGGIO.  
(1) THE GREASE NIPPLES IS TILTED ABOUT 6° TO HELP THE LUBRICATION.

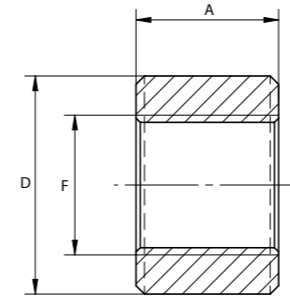

**BS...**

BORCHIA A SALDARE  
MATERIALE: S235 JR EN 10025  
FEMALE WELD BOSS  
MATERIALE: S235 JR EN 10025



SIGLA ARTICLE	F FILETTATURA THREAD	A	D
	Inch	mm	
BS14	1/4	16	22
BS38	3/8	17	26
BS12	1/2	18	30
BS34	3/4	20,4	36

ALTRI DIAMETRI FORNIBILI SU RICHIESTA  
OTHER SIZES AVAILABLE ON REQUEST

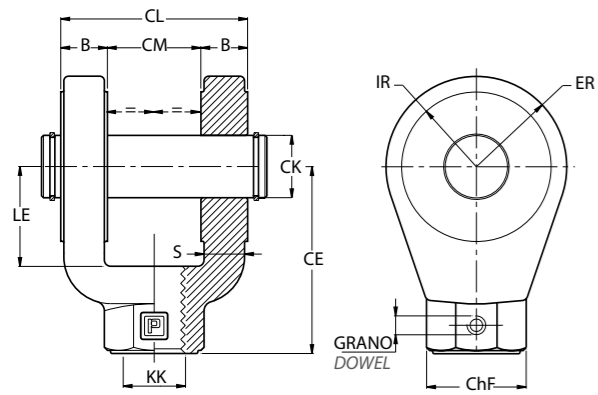

### KLP..

CERNIERA FEMMINA A FORCELLA

NORME: ISO 8133

MATERIALE: ACCIAIO S355JR UNI EN 10025

FORK JOINT HINGE

STANDARD: ISO 8133

MATERIAL: STEEL S355JR UNI EN 10025

SIGLA ARTICLE	CM	CK (H9) Ø FORCELLA Ø FORK	CE	CL	ChF	KK	LE	ER	B	IR	S	CARICO LIMITE LOAD FACTORS KN	GRANO DOWEL	PESO IN Kg. WEIGHT Kg.
KLP 10	12	10	32	24	19	M10X1.25	13	12	6	10	4	8	M 5X5	0.10
KLP 12	16	12	36	32	21	M12X1.25	19	17	8	14	5.5	12.5	M 5X5	0.18
KLP 14	20	14	38	40	21	M14X1.5	19	17	10	14	7.5	20	M 5X5	0.23
KLP 16	30	20	54	60	32	M16X1.5	32	29	15	24	11	32	M 6X6	0.90
KLP 20	30	20	60	60	32	M20X1.5	32	29	15	24	11	50	M 6X6	0.91
KLP 27	40	28	75	80	40	M27X2	39	34	20	29	17	80	M 6X6	1.92
KLP 33	50	36	99	100	55	M33X2	54	50	25	44	22	125	M 8X8	4.92
KLP 42	60	45	113	120	56	M42X2	57	53	30	49	27	200	M 8X8	6.53
KLP 48	70	56	126	140	75	M48X2	63	59	35	38	31	320	M 8X8	10.11
KLP 64	80	70	168	160	95	M64X3	83	78	40	45	37	500	M12X12	19.20
KLP 80	80	70	168	160	95	M80X3	83	78	40	45	37	500	M12X12	18.42

### PERNO KP.. PIN KP..

PER CERNIERA FEMMINA A FORCELLA

NORME: ISO 8133

MATERIALE: PR 80 (35SMnPb10) / C40

FOR FORK JOINT HINGE

STANDARD: ISO 8133

MATERIAL: PR 80 (35SMnPb10) / C40

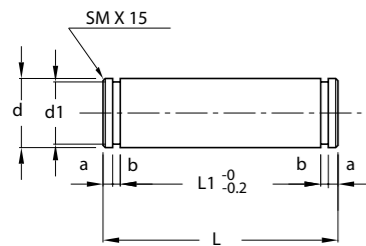

SIGLA ARTICLE	d (f8)	L	d1	L1	a	b	PESO IN Kg. WEIGHT Kg.	USATO PER CERNIERA A FORCELLA USED FOR FORK JOINT HINGE
KP 10	10	34	9.6	29	1.40	1.10	0.02	KLP 10
KP 12	12	43	11.5	37	1.90	1.10	0.04	KLP 12
KP 14	14	51	13.4	45	1.90	1.10	0.06	KLP 14
KP 16 ÷ 20	20	73	19	66	2.20	1.30	0.18	KLP 16 / KLP 20
KP 27	28	95	26.6	87	2.40	1.60	0.46	KLP 27
KP 33	36	117	34	107	3.15	1.85	0.93	KLP 33
KP 42	45	139	42.5	129	3.15	1.85	1.74	KLP 42
KP 48	56	161	53	149	3.80	2.17	3.11	KLP 48
KP 64 ÷ 80	70	181	67	169	3.35	2.65	5.47	KLP 64 / KLP 80

(\*) SU RICHIESTA DISPONIBILI CON TRATTAMENTO DI FOSFATAZIONE

(\*) AVAILABLE WITH PHOSPHATING TREATMENT

### FORCELLE FILETTATE THREADED FORKS

MARERIALE: C40

MATERIAL: C40

ART.	F	A	B	d	L	L1	N	C	PESO IN Kg. WEIGHT Kg.
FF 1700	M 16X1.5	16	35	16.20	55	39	24	16	0.29
FF 1702	M 20X1.5	20	40	20.25	65	45	30	20	0.41
FF 1704	M 24X2	25	50	25.25	70	50	30	20	0.63
FF 1706	M 30X2	30	60	30.25	90	65	35	25	1.35
FF 1708	M 33X2	35	70	35.25	105	75	40	30	2.16

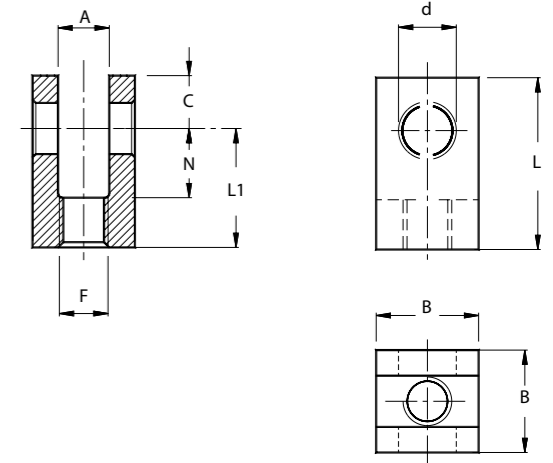

### FORCELLE A SALDARE WELDABLE FORKS

MARERIALE: C40

MATERIAL: C40

ART.	A	B	d	L	L1	N	C	PESO IN Kg. WEIGHT Kg.
FS 1710	16	35	16.20	50	34	24	16	0.27
FS 1712	20	40	20.25	60	40	30	20	0.38
FS 1714	25	50	25.25	65	45	30	20	0.68
FS 1716	30	60	30.25	75	50	35	25	1.07
FS 1720	35	70	35.25	85	55	40	30	1.63

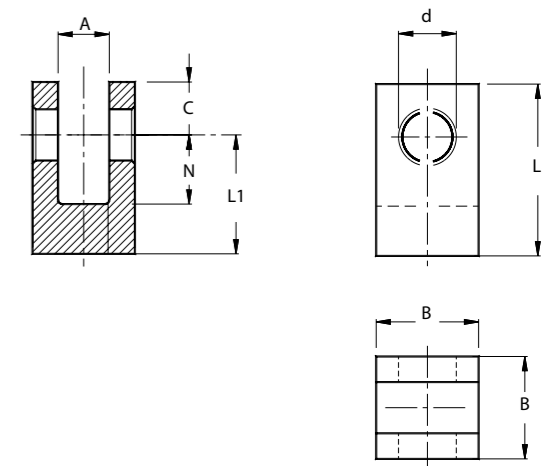

**I...SB** ANELLI INTERNI DI SPALLAMENTO PER FORI  
INSIDE RINGS FOR HOLE SHOULDERS

ART.	FORO HOLE d	SNODO BEARING Ø	CAVA GROVE d1	ANELLO RING	
				d2	s
I 22 SB	22	12	22.6	23.0	1.2
I 26 SB	26	15	26.8	27.2	1.2
I 28 SB	28	16	28.8	29.2	1.2
I 30 SB	30	17	31.0	31.4	1.5
I 35 SB	35	20	36.0	36.4	1.5
I 42 SB	42	25	43.2	43.8	1.5
I 47 SB	47	30	48.2	48.8	1.5
I 52 SB	52	32	53.5	54.3	1.5
I 55 SB	55	35	56.5	57.3	1.5

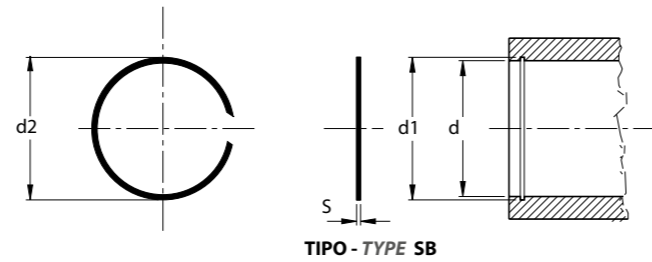

TIPO - TYPE SB

**I...DIN** ANELLI INTERNI RINFORZATI DI SPALLAMENTO PER FORI  
REINFORCED INSIDE RINGS FOR HOLE SHOULDERS

ART.	FORO HOLE d	SNODO BEARING Ø	CAVA GROVE d1	ANELLO RING	
				d2	s
I 62 DIN	62	40	65	66.2	2.0
I 68 DIN	68	45	71	72.5	2.5
I 75 DIN	75	50	78	79.5	2.5
I 90 DIN	90	60	83.5	95.5	3.0
I 95 DIN	95	63	90.5	100.5	3.0
I 105 DIN	105	70	109	112.0	4.0
I 120 DIN	120	80	124	127.0	4.0
I 130 DIN	130	90	134	137.0	4.0
I 150 DIN	150	100	155	158.0	4.0
I 160 DIN	160	110	165	169.0	4.0
I 180 DIN	180	120	185	189.5	4.0
I 180 DIN	180	125	185	189.5	4.0
I 230 DIN	230	160	236	242.0	5.0
I 290 DIN	290	200	298	305.0	5.0

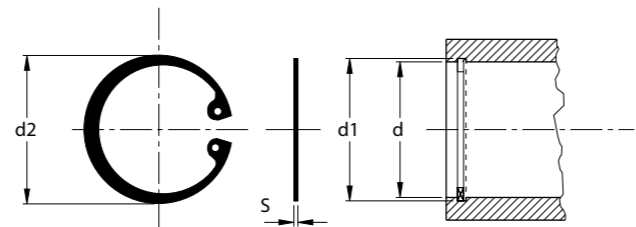

TIPO - TYPE DIN 472  
UNI 3654-7437

**E...DIN** ANELLI ESTERNI D'ARRESTO PER ALBERI  
CUT OFF OUTSIDE RINGS FOR SHAFTS

ART.	ALBERO HOLE d	CAVA GROVE d1	ANELLO RING	
			d2	s
E 2510	10	9.6	9.3	1.0
E 2512	12	11.5	11.0	1.0
E 2514	14	13.4	12.9	1.0
E 2516	16	15.2	14.7	1.0
E 2520	20	19.0	18.5	1.2
E 2525	25	23.9	23.2	1.2
E 2527	27	25.6	24.9	1.2
E 2528	28	26.6	25.9	1.5
E 2532	32	30.3	29.6	1.5
E 2534	34	32.3	31.5	1.5
E 2535	35	33.0	32.2	1.5
E 2536	36	34.0	33.2	1.75
E 2540	40	37.5	36.5	1.75
E 2545	45	42.5	41.5	1.75
E 2550	50	47.0	45.8	2.0
E 2556	56	53.0	51.8	2.0
E 2563	63	60.0	58.8	2.0
E 2570	70	67.0	65.5	2.5
E 2580	80	76.5	74.5	2.5
E 25100	100	96.5	94.5	3.0

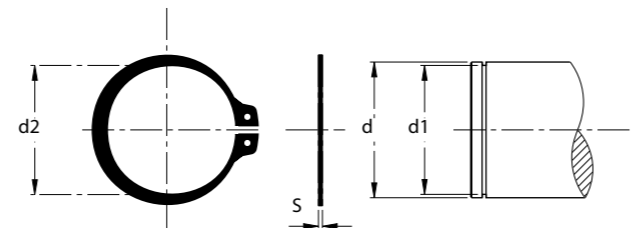

TIPO - TYPE A DIN 471  
UNI 3653 - 7435

**SUPPORTI PER CILINDRI IDRAULICI**  
**BRACKETS FOR HYDRAULIC CYLIDERS**

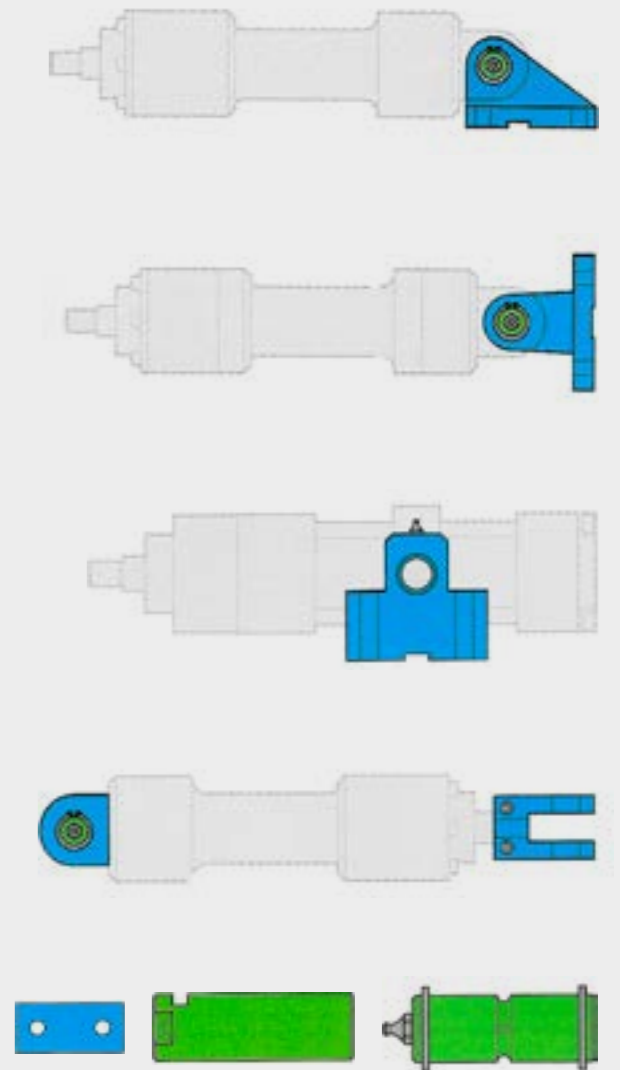
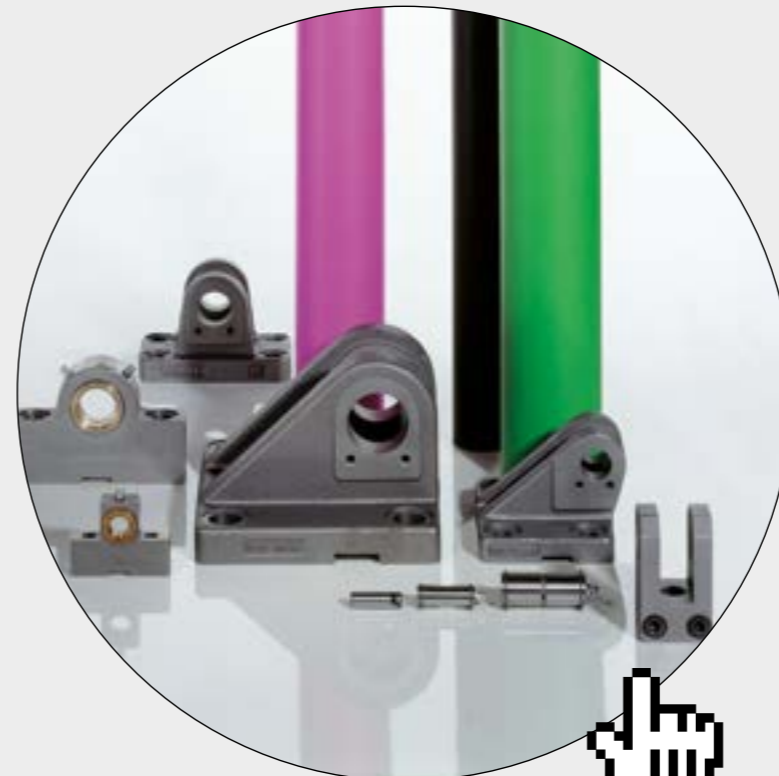

ISO 8132  
ISO 8133  
DIN 24556

**A richiesta - accoppiamento IKB e IKA con TAPR...CE**  
**On request - assembling IKB and IKA with TAPR...CE**

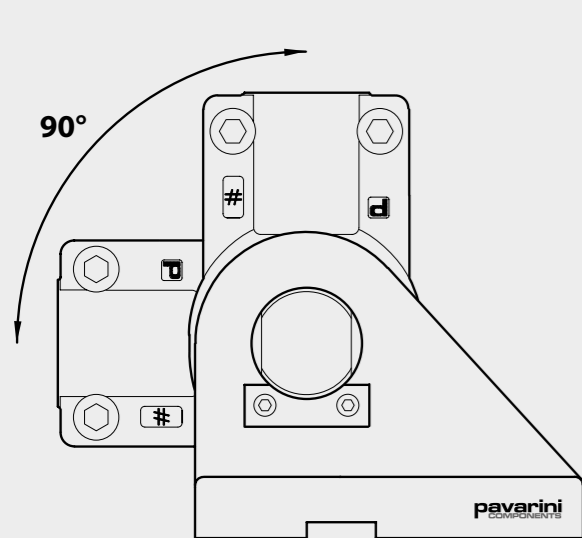
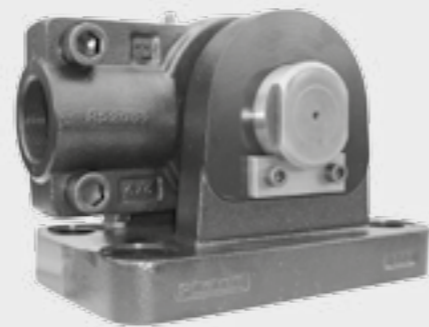

**ACCOPIAMENTO IKB CON TAPR...CE**  
*ASSEMBLING IKB WITH TAPR...CE*

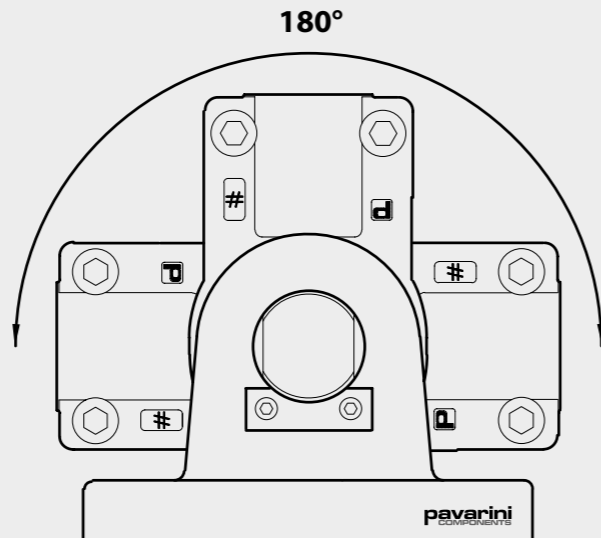

**ACCOPIAMENTO IKA CON TAPR...CE**  
*ASSEMBLING IKA WITH TAPR...CE*

SUPPORTI PER CILINDRI IDRAULICI SECONDO NORMATIVE ISO 8132-8133 E DIN 24556  
*BRACKETS FOR HYDRAULIC CYLINDERS STANDARD ISO 8132-8133 AND DIN 24556*

PAG.

47-48

PERNI PER SUPPORTI, PIASTRINI DI FISSAGGIO, ANELLI ESTERNI D'ARRESTO  
*BRACKET PINS, FIXING PLATES, "SEEGER" RINGS*

49-51

FORCELLE D'ESTREMITÀ, PERNI, SUPPORTI BASCULANTI A DUE PERNI  
*FORKS END, PINS, TRUNNIONS*

52

SUPPORTI  
*BRACKETS*

53

**TABELLA COMPARATIVA SUPPORTI PAVARINI COMPONENTS**  
*CROSS REFERENCE BRACKETS PAVARINI COMPONENTS*

<b>pavarini</b> COMPONENTS	<b>International Reference</b>
IKA...	CBA...
IKB...	CBB...
DK...	LD...N
KPA...	BS...
KPB...	BA...
KPE...	PPA...
PPP...	A...
KPC...; KPD...	PP...
IF...	RC...
IS...	TB...
ISS...	SD...

## Suggerimenti per l'inserimento dei perni negli occhielli dei supporti

I supporti per cilindri oleodinamici che presentiamo in questo catalogo trovano impiego nei più svariati settori della meccanica.

Diamo perciò qui di seguito alcuni consigli sul metodo di montaggio, suggerito anche dalle norme DIN 24556 e ISO 8132.

I perni con piccoli diametri possono essere piantati con un mandrino di ottone o rame.

Il mandrino deve avere lo stesso diametro del perno. Sono da evitare colpi diretti con un martello che potrebbe provocare il danneggiamento del perno.

In caso di diametri maggiori, i perni con accoppiamento m6 o h6 non si possono più montare con semplici utensili battenti. In questo caso il montaggio può essere facilitato tramite un sostegno termico, perciò il supporto può essere riscaldato con compressore ad aria calda e il perno raffreddato in un congelatore.

In caso di una grossa maggiorazione dei perni rispetto all'alesaggio, si deve portare la differenza della temperatura tra il supporto e i perni ad almeno 40°C. I supporti non vanno comunque mai riscaldati oltre i 60°C, al fine di evitare la distruzione del lubrificante, o eventuali guarnizioni presenti.

Sconsigliamo l'utilizzo di fiamme dirette, come per esempio il cannello da saldatura o la lampada per scaldare, poiché porterebbero ad un surriscaldamento del particolare. I perni non devono essere raffreddati al di sotto dei -50°C, poiché possono subentrare cambiamenti di struttura con variazione notevole del volume.

## Suggestion for the fitting of the pins into the eyelet of the brackets

The brackets for hydraulic cylinders presented in this catalogue find a wide application in the different fields of the mechanics.

Therefore we want to give some suggestions on the assembling system in accordance with the standards DIN 24556 and ISO 8132.

The pins with small diameters can be fitted using a brass or copper spindle. The spindle must be of the same diameter of the pin. Avoid any direct stroke of a hammer on the pin which could be damaged.

With bigger diameters, the pins with M6 or H6 coupling cannot be assembling using normal stroking tools. In this specific case the assembly can be easier using a thermic source. You can warm up the bracket using an air compressor and freeze the pin.

In the case you have a very big increase of the pins towards the bore, you need to arrive at a difference of the temperature between pins and brackets of at least 40 C. However, the brackets have not to be warmed up over 60°C, in order to avoid to destroy the lubrication or possible gaskets.

We suggest to avoid any usage of direct flame as for example welding torch or lamps to warm, as they could bring to an overheating of the piece. The pins have not be cooled under - 50° C, because you could obtain changes in the structure with an important difference of the volume.

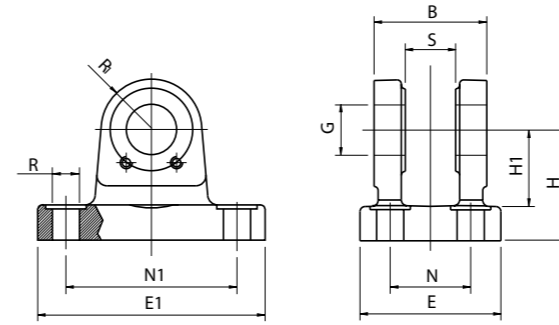

### IKA... (CBA...)

SUPPORTO 180°  
ISO 8132  
100-250 bar  
MATERIALE: EN-GJS 500/7

BRACKET 180°  
ISO 8132  
100-250 BAR  
MATERIAL: EN-GJS 500/7

SIGLA ARTICLE	B (h16)	E	E1	G (H9)	H (J512)	H1 min	N (J514)	N1 (J514)	R1	R (H13)	S (A13)	FORZA NOMINALE RATED VALUE	PESO IN Kg. WEIGHT Kg.
IKA 10	24	33	60	10	32	22	17	42	10	6.6	10	5	0.1
IKA 12	28	40	70	12	34	22	20	50	12	9	12	8	0.31
IKA 16	36	50	90	16	40	27	26	65	16	11	16	12.5	0.59
IKA 20	45	58	98	20	45	30	32	75	20	11	20	20	0.9
IKA 25	56	70	113	25	55	37	40	85	25	13.5	25	32	1.6
IKA 32	70	85	143	32	65	43	50	110	32	17.5	32	50	2.8
IKA 40	90	108	170	40	76	52	65	130	40	22	40	80	5.0
IKA 50	110	130	220	50	95	65	80	170	50	26	50	125	10.1
IKA 63	140	160	270	63	112	75	100	210	63	33	63	200	15.4
IKA 80	170	210	320	80	140	95	125	250	80	39	80	320	30.0
IKA 100	210	260	400	100	180	120	160	315	100	45	100	500	60.2

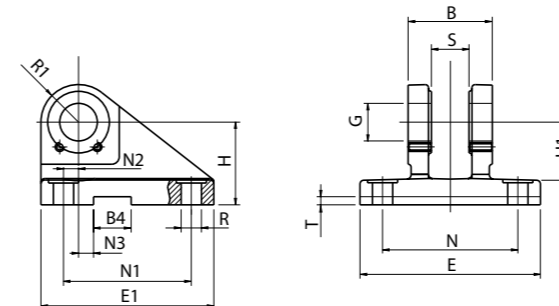

### IKB... (CBB...)

SUPPORTO 90°  
ISO 8132  
100-250 bar  
MATERIALE: EN-GJS 500/7

BRACKET 90°  
ISO 8132  
100-250 BAR  
MATERIAL: EN-GJS 500/7

SIGLA ARTICLE	B (h16)	B4 (N9)	E	E1	G (H9)	H (js13)	H1 min	N (js13)	N1 (js13)	N2 (J514)	N3 (J514)	R1	R (H13)	S (A13)	T +0.3 0	FORZA NOMINALE RATED VALUE	PESO IN Kg. WEIGHT Kg.
IKB 10	24	8	56	60	10	32	22	39	44	2	10	10	6.6	10	3.3	5	0.31
IKB 12	28	10	72	65	12	34	22	52	45	2	10	12	9	12	3.3	8	0.55
IKB 16	36	16	90	80	16	40	27	65	55	3.5	10	16	11	16	4.3	12.5	0.9
IKB 20	45	16	100	95	20	45	30	75	70	7.5	10	20	11	20	4.3	20	1.5
IKB 25	56	25	120	115	25	55	37	90	85	10	10	25	13.5	25	5.4	32	2.7
IKB 32	70	25	145	145	32	65	43	110	110	14.5	6	32	17.5	32	5.4	50	4.5
IKB 40	90	36	185	170	40	76	52	140	125	17.5	6	40	22	40	8.4	80	8.5
IKB 50	110	36	215	200	50	95	65	165	150	25	-	50	26	50	8.4	125	13.5
IKB 63	140	50	270	230	63	112	75	210	170	33	-	63	33	63	11.4	200	23.4
IKB 80	170	50	320	280	80	140	95	250	210	45	-	80	39	80	11.4	320	38.5
IKB 100	210	63	405	345	100	180	120	315	250	52.5	-	100	52	100	12.4	500	90.3



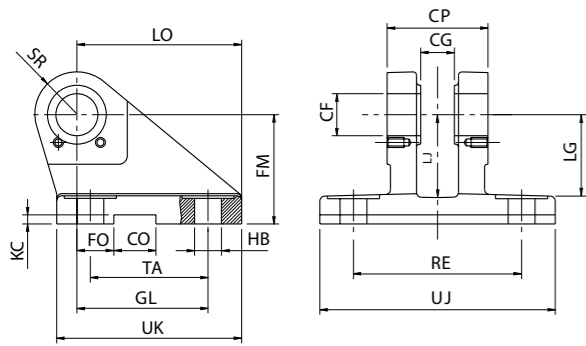

### DK... (LD...N)

SUPPORTO  
DIN 24556  
MATERIALE: EN-GJS 500/7

BRACKET  
DIN 24556  
MATERIAL: EN-GJS 500/7

SIGLA ARTICLE	CP (h14)	CG +0.3 +0.1	FM (js11)	CF (K7)	LJ	LG	LO	SR	UJ	UK	GL	TA (js13)	RE (js13)	FO (js14)	CO (N9)	KC +0.3 0	HB	FORZA NOMINALE RATED VALUE	PESO IN Kg. WEIGHT Kg.
																		KN.	
mm.																			
DK 12	30	10	40	12	29	28	56	12	75	60	46	40	55	16	10	3.3	9	8	0.52
DK 16	40	14	50	16	38	37	74	16	95	80	61	55	70	18	16	4.3	11	12.5	1.05
DK 20	50	16	55	20	40	39	80	20	120	90	64	58	85	20	16	4.3	13.5	20	1.72
DK 25	60	20	65	25	49	48	98	25	140	110	78	70	100	22	25	5.4	15.5	32	2.72
DK 30	70	22	85	30	63	62	120	30	160	135	97	90	115	24	25	5.4	17.5	50	5.15
DK 40	80	28	100	40	73	72	148	40	190	170	123	120	135	24	36	8.4	22	80	9.3
DK 50	100	35	125	50	92	90	190	50	240	215	155	145	170	35	36	8.4	30	125	18.3
DK 60	120	44	150	60	110	108	225	60	270	260	187	185	200	35	50	11.4	39	200	35
DK 80	160	55	190	80	142	140	295	80	320	340	255	260	240	35	50	11.4	45	320	63
DK 100	200	70	210	100	152	150	335	100	400	400	285	300	300	35	63	12.4	48	500	109

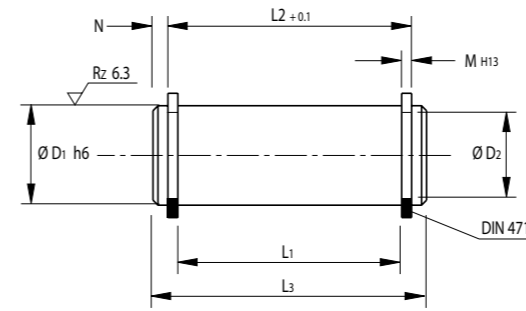

### KPA... (BS...)

PERNO PER SUPPORTO DK...  
MATERIALE: 20 Mn Cr5

PIN FOR BRACKET DK...  
MATERIAL: 20 Mn Cr5

SIGLA ARTICLE	D1 (h6)	D2	L1	L2	L3	N	M	ANELLO DI BLOCCAGGIO BLOCK RING	PESO IN Kg. WEIGHT Kg.
KPA 12	12	11.5	30	33	35	1	1.1	12 X 1	0.03
KPA 16	16	15.2	40	43	46	1.5	1.1	16 X 1	0.08
KPA 20	20	19	50	53.4	57	1.8	1.3	20 X 1.2	0.14
KPA 25	25	23.9	60	63.4	67	1.8	1.3	25 X 1.2	0.26
KPA 30	30	28.6	70	74	79	2.5	1.6	30 X 1.5	0.44
KPA 40	40	37.5	80	84.5	93	4.2	1.85	40 X 1.75	0.90
KPA 50	50	47	100	105	115	5	2.15	50 X 2	1.70
KPA 60	60	57	120	125	135	5	2.15	60 X 2	3.10
KPA 80	80	76.5	160	166	178	6	2.65	80 X 2.5	7.10
KPA 100	100	96.5	200	207	221	7	3.15	100 X 3	14.40

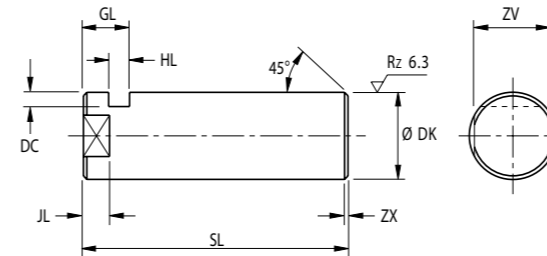

### KPB... (BA...)

PERNO PER SUPPORTO DK...  
ISO 8133  
MATERIALE: 20 Mn Cr5

PIN FOR BRACKET DK...  
ISO 8133  
MATERIAL: 20 Mn Cr5

SIGLA ARTICLE	DK (h6)	SL	GL	HL	JL	ZV	DC	ZX	PESO IN Kg. WEIGHT Kg.
KPB 12	12	40	8	3.3	4.5	10	4	1	0.04
KPB 16	16	50	8	3.3	5.5	13	4	1	0.08
KPB 20	20	62	10	4.5	5.5	17	5	1.5	0.15
KPB 25	25	72	10	4.5	5.5	22	5	1.5	0.27
KPB 30	30	85	13	5.5	7.5	24	6	2	0.41
KPB 40	40	100	16	6.5	9.5	32	7	2	0.91
KPB 50	50	122	19	9	10	41	8	2	1.71
KPB 60	60	145	20	9	11	50	9	2	3.13
KPB 80	80	190	26	11	15	70	11	3	7.14
KPB 100	100	235	30	13	15	90	14	3	14.4

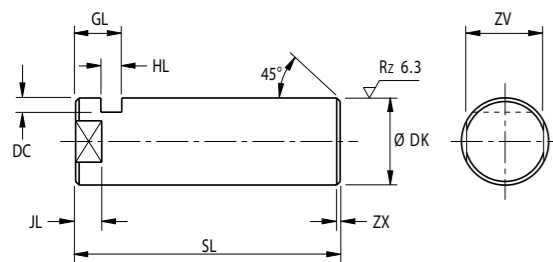

**KPE...  
(PPA...)**

PERNO PER SUPPORTI IKA.../ IKB...  
MATERIALE: 20 Mn Cr5

PIN FOR BRACKETS IKA.../ IKB...  
MATERIAL: 20 Mn Cr5

SIGLA ARTICLE	DK (m6)	SL	GL	HL	JL	ZV	DC	ZX	PESO IN Kg. WEIGHT Kg.
mm.									
KPE 10	10	34	8	3.3	4.5	8	3	1	0.021
KPE 12	12	38	8	3.3	4.5	10	4	1	0.033
KPE 16	16	46	8	3.3	5.5	13	4	1	0.07
KPE 20	20	58	10	4.5	5.5	17	5	1.5	0.14
KPE 25	25	69	10	4.5	6.5	21	5	1.5	0.27
KPE 32	32	87	13	5.5	8.5	27	6	2	0.45
KPE 40	40	110	16	6.5	8.5	32	7	2	0.91
KPE 50	50	133	19	9	8.5	41	8	2	1.71
KPE 63	63	164	20	9	8.5	55	9	2	3.13
KPE 80	80	202	26	11	11.5	65	11	3	7.14
KPE 100	100	246	28	13	15.0	90	14	3	15.0

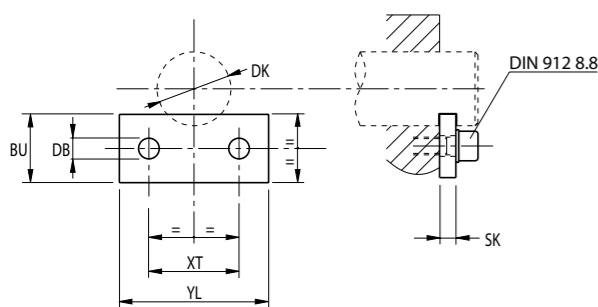

**PPP..  
(A...)**

PIASTRINO DI FISSAGGIO PER PERNI KPB.../ KPE...  
ISO 8133  
MATERIALE: S355JR - ST 52.3

FIXING PLATES FOR PINS KPB.../ KPE...  
ISO 8133  
MATERIAL: S355JR - ST 52.3

SIGLA ARTICLE	DB	DK	BU	SK	YL	XT	FILETTO FORI THREAD HOLES	ANELLO DI SICUREZZA SAFETY RING	PESO IN Kg. WEIGHT Kg.
mm.									
PPP 10 (A)	5.4	10/12	15	3	20	11	M 5X12	5	0.02
PPP 12	6.4	12	15	3	27	16	M 6X12	6	0.02
PPP 16 (A)	6.4	16	15	3	30	16	M 6X12	6	0.02
PPM 16	6.4	16	15	3	40	25	M 6X12	6	0.03
PPP 20	6.4	20	18	4	40	25	M 6X16	6	0.04
PPP 25	6.4	25	18	4	40	25	M 6X16	6	0.04
PPP 30	6.4	30	20	5	45	30	M 6X16	6	0.04
PPP 32 (A)	6.4	32	20	5	45	30	M 6X16	6	0.04
PPP 40	8.4	40	20	6	62	42	M 8X20	8	0.08
PPP 50	8.4	50	25	8	65	45	M 8X20	8	0.09
PPP 60	10.5	60	25	8	80	55	M10X25	10	0.17
PPP 63 (A)	10.5	63	25	8	80	55	M10X25	10	0.17
PPP 80	10.5	80	30	10	90	60	M10X25	10	0.25
PPP 100	10.5	100	40	12	120	90	M10X25	10	0.49

(A) FUORI NORMATIVA - WITHOUT STANDARD

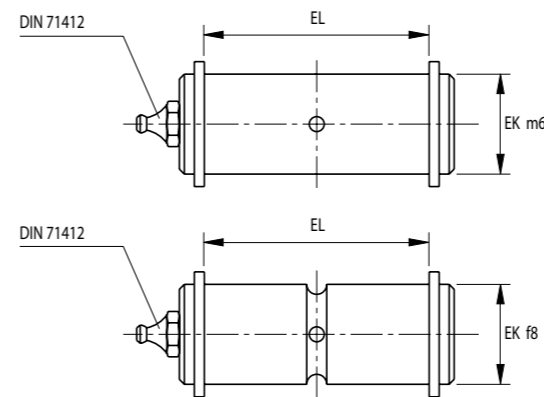

**KPC...**

**KPD...  
(PP...)**

PERNO KPC PER SUPPORTI IKA.../ IKB.../ IF... TOLLERANZA Ø m6  
ISO 8132 - MATERIALE: 20 Mn Cr 5

PERNO KPD CON GOLA IN MEZZERIA PER SUPPORTI IKA.../ IKB.../ IF...  
TOLLERANZA Ø f8 ISO 8132 - MATERIALE: 20 Mn Cr 5

PIN KPC FOR BRACKETS IKA.../ IKB.../ IF... - TOLERANCE Ø m6  
ISO 8132 - MATERIAL: 20 Mn Cr 5

PIN KPD WITH MID GROVE FOR BRACKETS IKA.../ IKB.../ IF... - TOLERANCE Ø f8  
ISO 8132 - MATERIAL: 20 Mn Cr 5

SIGLA ARTICLE	SIGLA ARTICLE	EK (f8/m6)	EL (H16)	FORZA NOMINALE RATED FORCE	PESO IN Kg. WEIGHT Kg.
			mm.	KN	
KPC 10	KPD 10	10	25	5	0.01
KPC 12	KPD 12	12	29	8	0.03
KPC 16	KPD 16	16	37	12.5	0.60
KPC 20	KPD 20	20	46	20	0.13
KPC 25	KPD 25	25	57	32	0.25
KPC 32	KPD 32	32	72	50	0.50
KPC 40	KPD 40	40	92	80	1.00
KPC 50	KPD 50	50	112	125	1.90
KPC 63	KPD 63	63	142	200	3.80
KPC 80	KPD 80	80	172	320	7.60

**E...DIN ANELLI ESTERNI D'ARRESTO PER ALBERI DIN 471 - UNI 3653 - 7435  
CUT OFF OUTSIDE RINGS FOR SHAFTS DIN 471 - UNI 3653 - 7435**

ART.	ALBERO SHAFT d	CAVA GROVE d1	ANELLO SAFETY	
			d2	S
E 2510	10	9.6	9.3	1.0
E 2512	12	11.5	11.0	1.0
E 2514	14	13.4	12.9	1.0
E 2516	16	15.2	14.7	1.0
E 2520	20	19.0	18.5	1.2
E 2525	25	23.9	23.2	1.2
E 2527	27	25.6	24.9	1.2
E 2528	28	26.6	25.9	1.5
E 2532	32	30.3	29.6	1.5
E 2534	34	32.3	31.5	1.5
E 2535	35	33.0	32.2	1.5
E 2536	36	34.0	33.2	1.75
E 2540	40	37.5	36.5	1.75
E 2545	45	42.5	41.5	1.75
E 2550	50	47.0	45.8	2.0
E 2556	56	53.0	51.8	2.0
E 2563	63	60.0	58.8	2.0
E 2570	70	67.0	65.5	2.5
E 2580	80	76.5	74.5	2.5
E 25100	100	96.5	94.5	3

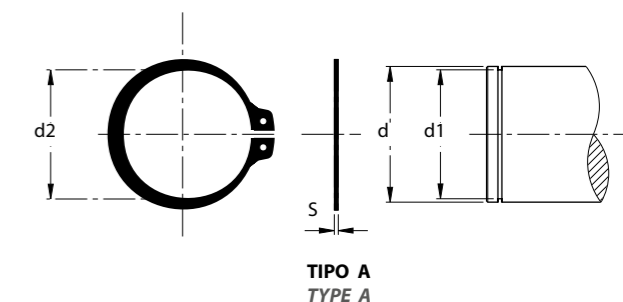

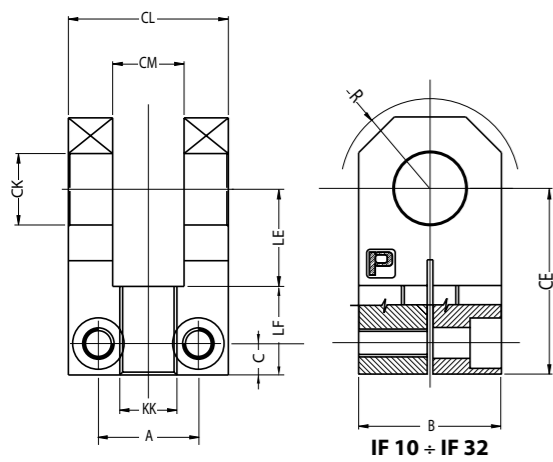

**IF...  
(RC...)**

FORCELLA D'ESTREMITA'  
NORME: ISO 8132  
MATERIALE: S355JR - ST 52.3

FORK END  
STANDARD: ISO 8132  
MATERIAL: S355JR - ST 52.3

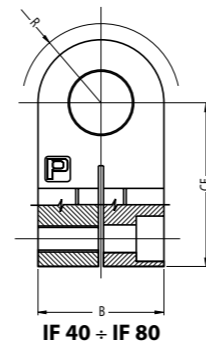

**IF 40 + IF 80**

SIGLA ARTICLE	CK (H9)	CL (h16)	CM (A13)	CE (js13)	LE min.	KK (6H)	LF	A	B	C	R max.	FORZA NOMINALE RATED FORCE	VITE UNI 5931 SCREW UNI 5931	PESO IN Kg. WEIGHT Kg.
<b>IF 10 (1)</b>	10	24	10	37	18	M10X1.25	19	16	20	7	11	5	M3X12	0.10
<b>IF 12</b>	12	28	12	38	18	M12X1.25	20	18	25	7	16	8	M14X16	0.16
<b>IF 16</b>	16	36	16	44	22	M14X1.5	22	24	30	8	20	12.5	M6X20	0.27
<b>IF 20</b>	20	45	20	52	27	M16X1.5	25	28	40	9	25	20	M8X30	0.53
<b>IF 25</b>	25	56	25	65	34	M20X1.5	31	35	50	11	32	32	M10X35	1.12
<b>IF 32</b>	32	70	32	80	41	M27X2	38	45	60	12	40	50	M12X45	2.18
<b>IF 40</b>	40	90	40	97	52	M33X2	45	60	80	16	50	80	M16X60	4.40
<b>IF 50</b>	50	110	50	120	64	M42X2	56	73	100	19	63	125	M20X70	7.60
<b>IF 63</b>	63	140	63	140	75	M48X2	65	93	120	25	71	200	M24X90	17.70
<b>IF 80</b>	80	170	80	180	94	M64X3	86	118	150	30	90	320	M30X100	30.60

(1) DISPONIBILITÀ E PREZZO A RICHIESTA  
AVAILABILITY AND PRICE UPON REQUEST

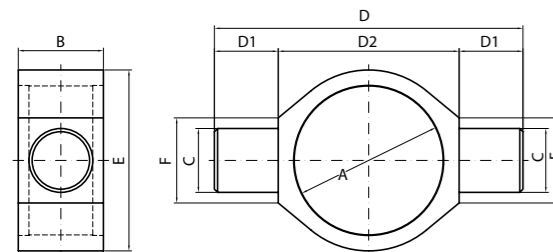

**PB...**

SUPPORTO BASCULANTE A DUE PERNI  
MATERIALE: S355JR - ST 52.3

TRUNNION  
MATERIAL: S355JR - ST 52.3

SIGLA ARTICLE	A (Ø)	B	C (Ø)	D	D1	D2	E (Ø)	F	PESO IN Kg. WEIGHT Kg.
<b>PB 050</b>	50	30	20	110	20	70	65	30	0,52
<b>PB 060</b>	60	35	25	130	25	80	75	35	0,79
<b>PB 070</b>	70	45	30	160	30	100	90	45	1,57
<b>PB 080</b>	80	50	35	180	35	110	100	50	2,03
<b>PB 092</b>	92	55	40	195	40	115	115	55	2,60
<b>PB 095</b>	95	55	40	195	40	115	115	55	2,40
<b>PB 105</b>	105	60	45	215	45	125	125	60	3,00
<b>PB 115</b>	115	70	50	245	50	145	145	70	5,30
<b>PB 140</b>	140	80	60	290	60	170	170	80	7,70

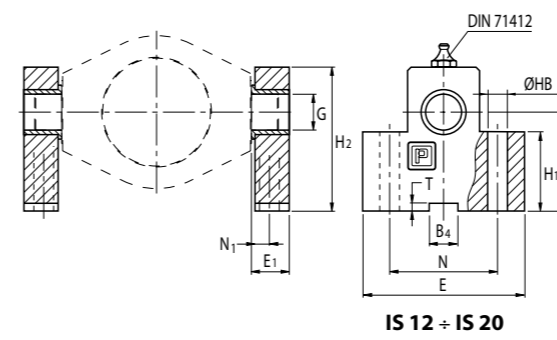

**IS 12 + IS 20**

**IS...  
(TB...)**

SUPPORTO  
ISO 8132  
MATERIALE: S355JR - ST 52.3

BRACKET  
ISO 8132  
MATERIAL: S355JR - ST 52.3

SIGLA ARTICLE	H (J512)	H1	H2	G (H7)	E	E1	N (js13)	N1 (js13)	B4 (N9)	T +0.3 0	ØHB (H13)	FORZA NOMINALE RATED VALUE	PESO IN Kg. WEIGHT Kg.
<b>IS 12</b>	34	25	49	12	63	17	40	8	10	3.3	9	8	0.43
<b>IS 16</b>	40	30	59	16	80	21	50	10	16	4.3	11	12.5	0.93
<b>IS 20</b>	45	38	69	20	90	21	60	10	16	4.3	11	20	1.21
<b>IS 25</b>	55	45	80	25	110	26	80	12	25	5.4	13.5	32	2.10
<b>IS 32</b>	65	52	100	32	150	33	110	15	25	5.4	17.5	50	4.12
<b>IS 40</b>	76	60	120	40	170	41	125	16	36	8.4	22	80	7.45
<b>IS 50</b>	95	75	140	50	210	51	160	20	36	8.4	26	125	13.66
<b>IS 63</b>	112	85	177	63	265	61	200	25	50	11.4	33	200	25.0
<b>IS 80</b>	140	112	220	80	325	81	250	31	50	11.4	39	320	54.0
<b>IS 100</b>	180	152	280	100	385	102	295	45	63	12.4	52	500	100

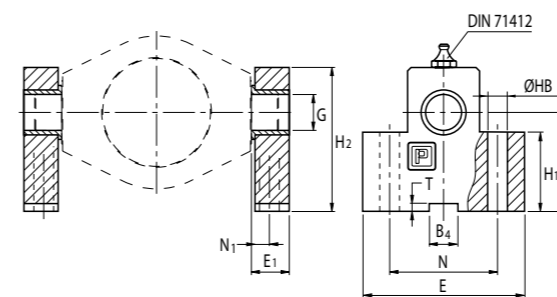

**ISS 12 + ISS 20**

**ISS...  
(SD...)**

SUPPORTO  
SENZA NORMATIVA CON INTERASSI MAGGIORATI  
MATERIALE: S355JR - ST 52.3

BRACKET  
NO STANDARD, WITH BIGGER DISTANCE BETWEEN CENTERS  
MATERIAL: S355JR - ST 52.3

SIGLA ARTICLE	H (J512)	H1	H2	G (H7)	E	E1	N (js13)	N1 (js13)	B4 (N9)	T +0.3 0	ØHB (H13)	FORZA NOMINALE RATED VALUE	PESO IN Kg. WEIGHT Kg.
<b>ISS 12</b>	38	25	55	12	63	17	40	8	10	3.3	9	8	0.45
<b>ISS 16</b>	45	30	65	16	80	21	50	10	16	4.3	11	12.5	0.90
<b>ISS 20</b>	55	38	80	20	90	21	60	10	16	4.3	11	20	1.34
<b>ISS 25</b>	65	45	90	25	110	26	80	12	25	5.4	14	32	2.32
<b>ISS 32</b>	75	52	110	32	150	33	110	15	25	5.4	18	50	4.47
<b>ISS 40</b>	95	60	140	40	170	41	125	16	36	8.4	22	80	8.0
<b>ISS 50</b>	105	72	150	50	210	51	160	20	36	8.4	26	125	13.50
<b>ISS 63</b>	125	87	195	63	265	61	200	25	50	11.4	33	200	27.43
<b>ISS 80</b>	150	112	230	80	325	81	250	31	50	11.4	39	320	54.0
<b>ISS 100</b>	200	150	300	100	410	101	320	42	63	12.4	52	500	112

**LSP - SNODI SFERICI**  
**LSP - SPHERICAL PLAIN BEARING**



TABELLA COMPARATIVA  
*CROSS REFERENCE*

56

ISTRUZIONI D'USO MONTAGGIO E MANUTENZIONE  
*OPERATING, MOUNTING AND MAINTENANCE INSTRUCTIONS*

58-61 ITA  
64-67 ENG

INDICE DEI PRODOTTI  
*PRODUCT RANGE*

62-63 ITA  
68-69 ENG

SNODI SFERICI RADIALI E ASSIALI LSP RICHIEDENTI MANUTENZIONE  
*SPHERICAL PLAIN BEARINGS REQUIRED MAINTENANCE*

SR..., SR...-2RS

70-71

SRC...

72-73

SRC...-2RS

74-75

SRL..., SRL...-2RS

76-77

SR...ZO, SR...ZO-2RS

78-79

SR...SX

80-81

SR...AX

82-83

SNODI SFERICI RADIALI E ASSIALI LSP NON RICHIEDENTI MANUTENZIONE  
*SPHERICAL PLAIN BEARINGS MAINTENANCE FREE*

SRB..., SRT...-2RS

84-85

SRLB..., SRLT...-2RS

86-87

SR...TGR, SR...TG3A-2RS

88-89

SR...SW  
*(INOX - STAINLESS STEEL)*

90-91

SR...AW

92-93

**TABELLA COMPARATIVA SNODI SFERICI**  
**CROSS REFERENCE SPHERICAL PLAIN BEARINGS**

<b>pavarini -LSP</b> <small>COMPONENTS</small>	<b>SKF</b>	<b>INA</b>	<b>International Reference</b>
SR	GE...E / ES	GE...DO	GE...E/ES
SR...-2RS	GE...ES-2RS	GE...DO-2RS	GE...ES-2RS
SRC...	GEG...ES	GE...LO	GEEW...ES
SRC...-2RS	GEM...ES-2RS	GE...HO-2RS	GEEM...ES-2RS
SRCT...	-	-	GEEW...ET
SRB...	GE...C	GE...UK	GE...C
SRT...-2RS	GE...TXE-2LS / TXA-2LS	GE...UK-2RS	GE...ET-2RS
SRL...	GEH...ES	GE...FO	GEG...ES
SRL...-2RS	GEH...ES-2RS	GE...FO-2RS	GEG...ES-2RS
SRLB...	GEH...C	GE...FW	GEG...C
SRLT...-2RS	GEH...TXE-2LS/TXA-2LS	GE...FW-2RS	GEG...ET/XT...-2RS
SR...TGR	GE...TXGR	-	GE...ET-X
SR...TG3A-2RS	GE...TXG3E-2LS / TXG3A-2LS	-	GE...XT...-2RS X
SR...ZO	GEZ...ES	GE...ZO	GEZ...ES
SR...ZO-2RS	GEZ...ES-2RS	GE-ZO-2RS	GEZ...ES-2RS
SR...SX	-	GE...SX	GAC...S
SR...SW	GAC...F	GE...SW	GAC...T
SR...AX	-	GE...AX	GX...S
SR...AW	GX...F	GE...AW	GX...T

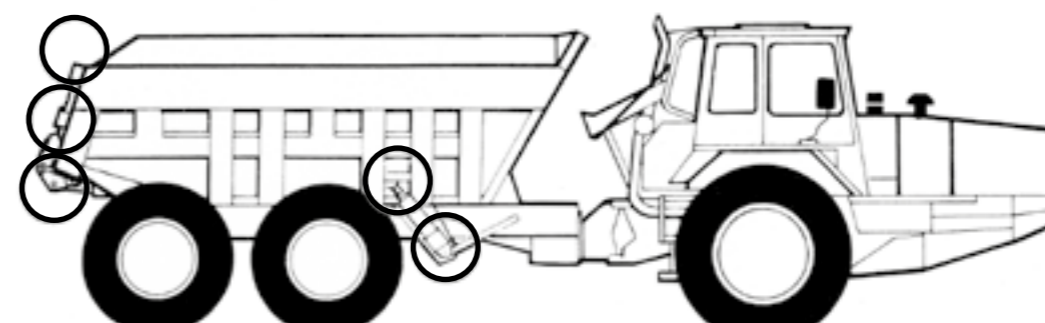
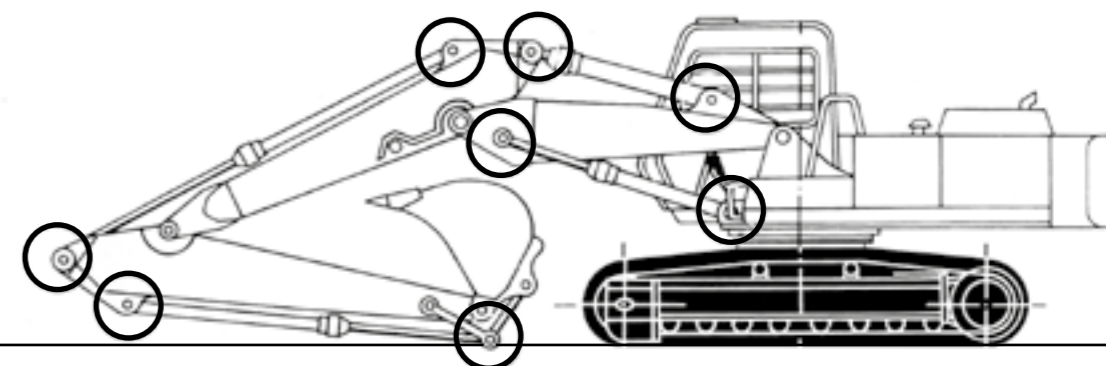

# Snodi sferici LSP- Pavarini Components

## ISTRUZIONI D'USO, MONTAGGIO E MANUTENZIONE

### MONTAGGIO

Il montaggio degli snodi sferici deve essere eseguito attenendosi alle indicazioni riportate di seguito.

La pulizia, il rispetto delle indicazioni di montaggio ed i corretti accoppiamenti sono il presupposto per assicurare un buon funzionamento e un'adeguata durata dello snodo.

Per evitare che gli snodi si sporchino dovranno essere tolti dal loro imballo originale solo al momento del montaggio; si dovrà avere cura che gli stessi non vengano a contatto con agenti ( oli, solventi, detergenti, ecc.) che possano compromettere le superfici di lavoro dello snodo.

Nel caso i particolari si dovessero incautamente sporcare si potranno pulire esclusivamente con un panno asciutto.

Gli elementi che accolgono lo snodo siano essi alberi o alloggiamenti dovranno essere, privi di bave e puliti, e verificati dimensionalmente.

Si consiglia di montare gli snodi sferici prevedendo interferenza nei relativi alloggiamenti e comunque rispettando le tolleranze di accoppiamento raccomandate (TAB.1).

Gli snodi che presentano l'anello esterno spaccato o diviso in due parti dovranno essere montati con la giunzione posta a 90° rispetto alla direzione di carico, ciò per evitare una riduzione della durata dello snodo (Fig.1).

Per eseguire un corretto montaggio degli snodi è consigliabile utilizzare una pressa assicurandosi un perfetto allineamento tra l'asse dello snodo e l'asse dell'alloggiamento.

Gli snodi non devono mai essere colpiti direttamente sugli anelli mediante martelli o giraviti, in quanto si possono danneggiare a discapito della durata (Fig.2).

### TOLLERANZE DI ACCOPPIAMENTO RACCOMANDATE

Per non pregiudicare il buon funzionamento dello snodo sferico si consigliano le seguenti tolleranze di accoppiamento:

TAB.1

<b>Snodi sferici radiali</b> accoppiamento Acciaio su Acciaio:	M7/m6 per alloggiamento in acciaio N7/m6 per alloggiamento in lega leggera
<b>Snodi sferici radiali</b> accoppiamento Acciaio su PTFE	K7/m6 per alloggiamento in acciaio M7/k6 per alloggiamento in lega leggera
<b>Snodi a contatto obliquo</b> accoppiamento Acciaio su Acciaio: accoppiamento Acciaio su PTFE:	M7/m6
<b>Snodi assiali</b> accoppiamento Acciaio su Acciaio accoppiamento Acciaio su PTFE:	J7/m6

Per agevolare il montaggio e lo smontaggio degli snodi sferici, si consiglia di prevedere sulle estremità dell'alloggiamento e del perno, degli smussi di invito di 10°-20°.



FIG. 1

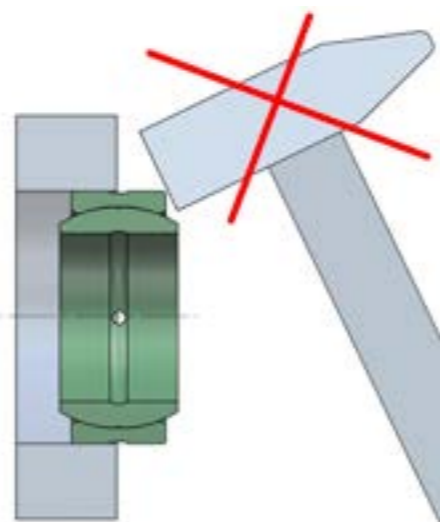

FIG. 2

Come attrezzatura per il montaggio si consiglia una calotta, la quale dovrà fare in modo di spingere solamente sull'anello che viene forzato come nel caso del montaggio su di un perno (Fig.3) o in un alloggiamento (Fig.4).

Nel caso di montaggio combinato (alloggiamento + perno) si dovrà utilizzare una calotta che presenti due superfici d'appoggio (Fig.5).

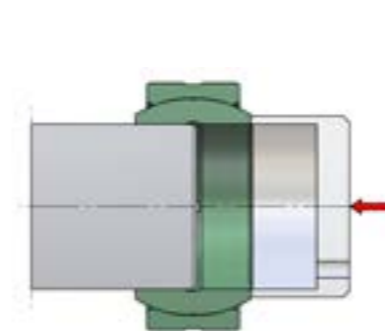

FIG. 3

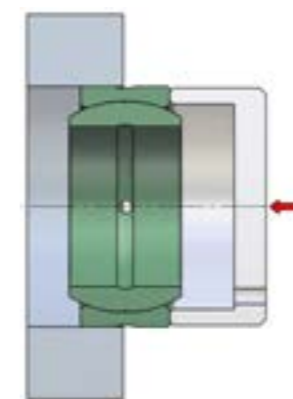

FIG. 4

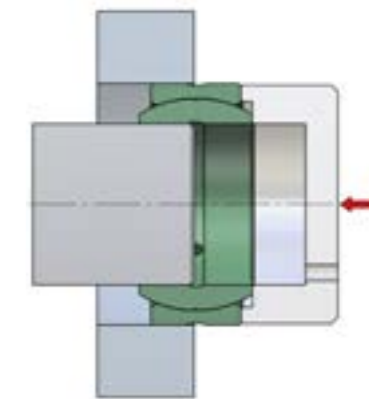

FIG. 5

Lo sforzo di montaggio **non deve mai essere fatto passare attraverso le superfici di lavoro dello snodo** (superficie di contatto tra anello esterno ed anello interno). (Fig.6 e Fig.7)

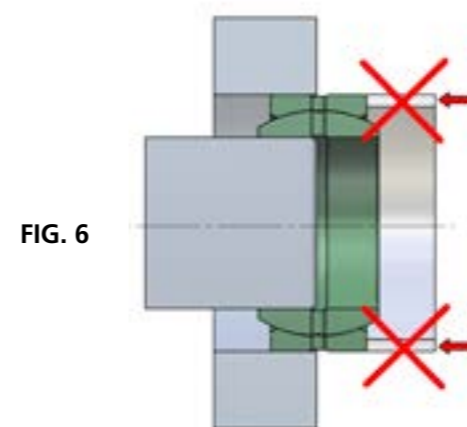

FIG. 6

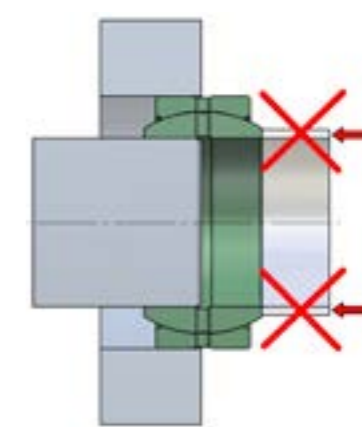

FIG. 7

Nel caso in cui si renda necessario preriscaldare lo snodo per agevolare l'inserimento su un perno, è assolutamente importante che lo snodo non venga mai riscaldato oltre i **110°C**, mentre per quanto riguarda gli snodi con tenuta **2RS**, non bisogna mai riscaldare oltre i **90°C**.

**Al fine di garantire le caratteristiche funzionali, si consiglia di proteggere le superfici degli snodi (anello esterno, anello interno e guarnizioni) da verniciatura. L'inosservanza a questa prescrizione potrebbe influire sulla durata degli snodi.**

Un montaggio non corretto può ridurre la durata di vita dello snodo e rappresenta essere una percentuale considerevole dei problemi di funzionamento, come ad esempio un accoppiamento troppo forzato tra snodo e alloggiamento, utensili di montaggio ed attrezzature non adatti, eccessiva forza applicata al montaggio.

Dopo il montaggio, deve verificarsi lo scorrimento tra l'anello interno e l'anello esterno dello snodo sferico. A tal fine l'anello interno deve essere solidale all'asse, mentre l'anello esterno deve essere solidale all'alloggiamento in cui viene montato.

## GIOCO INTERNO

### Gioco radiale

Per gioco radiale si definisce lo spostamento massimo possibile in senso radiale dell'anello interno verso la sede dell'anello esterno per mezzo di un determinato carico.

### Gioco assiale

Per gioco assiale si definisce lo spostamento massimo possibile dell'anello interno in senso assiale, da un estremo all'altro, tenendo ferma la posizione dell'anello esterno, per mezzo di un determinato carico

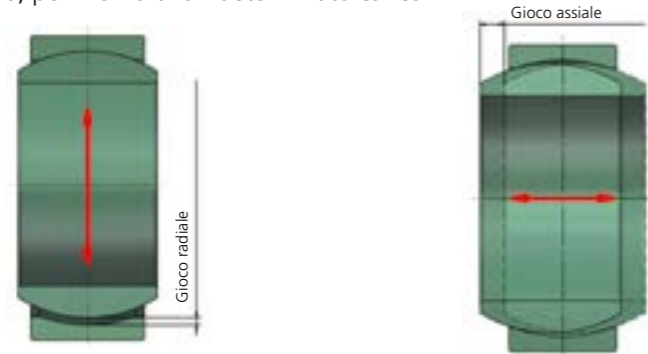

## LUBRIFICAZIONE

### Snodi sferici richiedenti manutenzione:

Gli snodi sferici acciaio su acciaio necessitano di un'adeguata manutenzione e lubrificazione. Il lubrificante, ha il compito di ridurre l'attrito, proteggere dalla corrosione e separare efficacemente le superfici metalliche di strisciamento.

Sulle superfici di lavoro degli snodi richiedenti manutenzione viene eseguito un trattamento di fosfatazione lubrificante al fine di favorire la fase iniziale di rodaggio.

E' buona norma una lubrificazione iniziale seguita da diverse fasi di rilubrificazione al fine di rimuovere i residui del lubrificante usato permettendo così la fuoriuscita di eventuali impurità. La scelta esatta del tipo di lubrificante è fatta tenendo in considerazione il tipo di sollecitazione a cui è sottoposto lo snodo. Per un campo generale di applicazioni, raccomandiamo grassi comunemente in commercio, anticorrosione resistenti alla pressione, a base di sapone di litio con additivi EP e sostanze solide lubrificanti.

Per fare arrivare il lubrificante all'interno dello snodo, sono state previste delle scanalature circolari e dei fori di lubrificazione su entrambi gli anelli. Bisogna prevedere inoltre un adeguato passaggio del grasso dall'alloggiamento mediante raccordo ingrassatore (FIG.8), oppure dal perno (FIG.9).

Al fine di migliorare la protezione alla corrosione in fase di stoccaggio questi snodi sono rivestiti di grasso. **E' importante evitare che questo tipo di grasso entri in contatto con la pelle affinché non subentrino eventuali reazioni allergiche o irritazioni.**

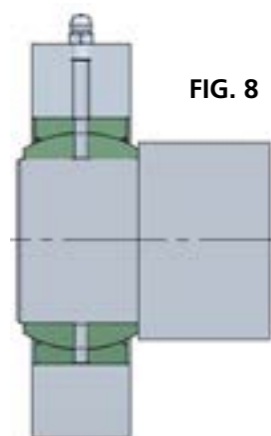

FIG. 8

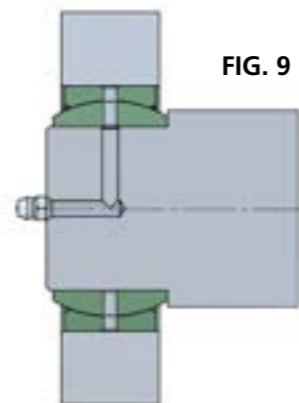

FIG. 9

### Snodi sferici esenti da manutenzione:

Gli snodi sferici esenti da manutenzione sono provvisti di speciali strati di strisciamento composti da materiali avente come base il PTFE (politetrafluoroetilene). Si tratta di materiali che grazie alle loro caratteristiche, come il bassissimo coefficiente d'attrito, consentono un regolare funzionamento senza lubrificazione.

Il loro campo di impiego è in tutte quelle applicazioni dove si riscontrano notevoli esigenze di utilizzo duraturo senza manutenzione oppure dove l'impiego di snodi con accoppiamento acciaio su acciaio non è consigliato a causa della parziale o totale impossibilità di lubrificazione.

Gli snodi sferici esenti da manutenzione sono disponibili in due combinazioni di superfici di lavoro in base alle dimensioni e al tipo materiale dell'anello esterno. L'anello interno in entrambe le configurazioni è composto da acciaio al cromo, temprato, e con superficie di lavoro sottoposta a cromatura dura.

L'anello esterno negli snodi con suffisso B è composto da acciaio con boccia di strisciamento in bronzo sinterizzato contenente PTFE pressata sulla parte interna dell'anello (Fig.10).

L'anello esterno negli snodi con suffisso T è composto da acciaio al cromo temprato, dove nella parte interna viene incollata una striscia di tessuto di PTFE di estrema qualità che garantisce carichi elevati (Fig.11).

Questi snodi non devono essere lubrificati poiché si andrebbe ad impedire il trasferimento di particelle di PTFE dall'anello esterno alla superficie dell'anello interno. Non è perciò previsto nessun sistema di rilubrificazione. Al fine di migliorare la protezione alla corrosione in fase di stoccaggio questi snodi sono rivestiti con un olio protettivo. **E' importante evitare che questo tipo di olio entri in contatto con la pelle affinché non subentrino eventuali reazioni allergiche o irritazioni.**

Bronzo sinterizzato-PTFE

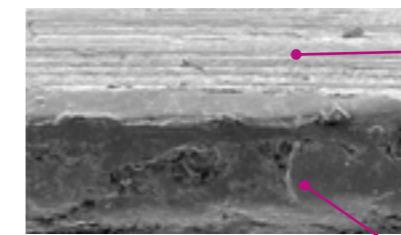
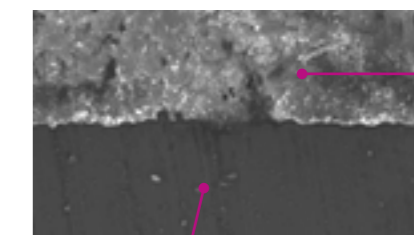

FIG. 10

Bronzo sinterizzato

Acciaio-Tessuto PTFE



Acciaio

Tessuto di PTFE

FIG. 11

## PROTEZIONI

Dove è richiesta una maggior protezione verso l'ambiente di lavoro, gli snodi vengono provvisti di guarnizioni striscianti montate su entrambi i lati dell'anello esterno **2RS**. Si tratta di tenute a labbro in materiale termoplastico con un campo di impiego che va da **-30°C a +110°C**. **Le guarnizioni LSP si distinguono dal colore Pantone 297 (FIG.12).**



FIG. 12

## SMONTAGGIO

Come nel caso del montaggio, lo sforzo di estrazione dello snodo deve essere sempre applicato sull'anello che si trova forzato, pertanto si privilegia come attrezzatura una calotta che andrà a spingere come rappresentato in (Fig. 13).

Gli snodi di piccole dimensioni si possono smontare dall'albero mediante un estrattore meccanico, applicando le griffe sull'anello interno o su un componente situato dietro lo snodo (Fig.14).

Nel caso in cui gli snodi debbano essere reimpiegati dopo lo smontaggio, vanno trattati con la stessa cura e le stesse raccomandazioni prestate durante la fase di montaggio.

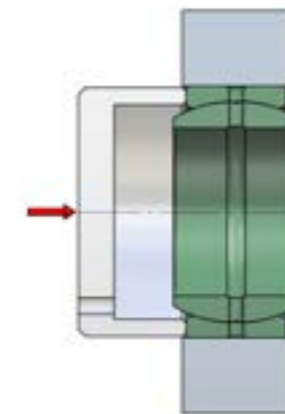

FIG. 13

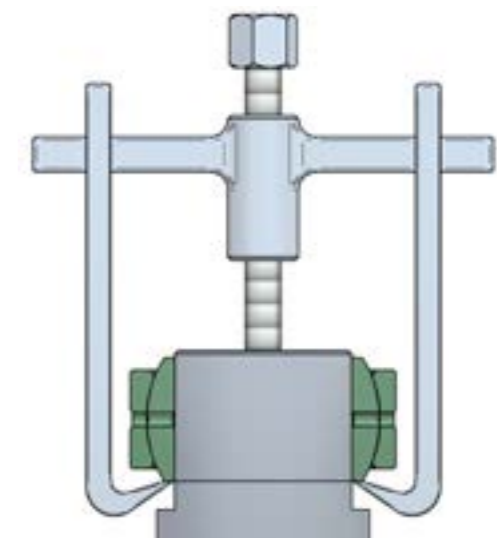

FIG. 14

# SNODI SFERICI RADIALI E ASSIALI - LSP

Si dividono innanzitutto in due categorie:

**a) Snodi sferici richiedenti manutenzione**

**b) Snodi sferici esenti da manutenzione**

**• I FATTORI DI CARICO DICHIARATI SI RIFERISCONO UNICAMENTE A SNODI SFERICI "PAVARINI" MARCHIATI "LSP"**

a) Appartengono alla prima categoria agli snodi sferici con l'accoppiamento di strisciamento acciaio su acciaio. Si tratta di snodi particolarmente indicati per l'utilizzo con carichi che agiscono in senso alternato, per carichi dinamici e d'urto, ed anche per forti carichi di tipo statico. All'interno di questa categoria troviamo gli snodi sferici radiali: il loro campo di applicazione è il cilindro idraulico, dove assistiamo regolarmente a situazioni di forti carichi radiali. Gli snodi sferici con accoppiamento acciaio su acciaio devono venire regolarmente rilubrificati a garanzia di un corretto funzionamento e per una sufficiente durata. A questo scopo vengono costruiti di serie, ad eccezione di alcuni tipi di piccole dimensioni, con scanalature sulla circonferenza e fori di lubrificazione sugli anelli interno ed esterno.

b) Gli snodi sferici esenti da manutenzione sono provvisti di speciali strati di strisciamento composti da materiali avente come base il PTFE (politetrafluoroetilene). Si tratta di materiali di realizzazione molto recente che, grazie alle loro caratteristiche, come il bassissimo coefficiente di attrito, consentono un regolare funzionamento senza lubrificazione.

Il loro campo di impiego è in tutte quelle applicazioni dove si riscontrano notevoli esigenze di utilizzo duraturo senza manutenzione oppure dove l'impiego di snodi con accoppiamento acciaio su acciaio non è consigliato a causa della parziale o totale impossibilità di lubrificazione.

Gli snodi sferici esenti da manutenzione sono indicati soprattutto per impieghi con carichi agenti in un solo senso con movimenti lenti.

## GAMMA DEI PRODOTTI

SNODO SFERICO	TIPO	DIAMETRO FORO (mm.)	ACCOPPIAMENTO SUPERFICI DI LAVORO	NECESSITÀ DI LUBRIFICAZIONE	CARATTERISTICHE COSTRUTTIVE	CAMPO DI APPLICAZIONE
	SR...	5 ÷ 300	ACCIAIO SU ACCIAIO	SI	Snodo sferico radiale. Gli anelli interno ed esterno sono temprati. L'anello esterno presenta una spaccatura assiale per il montaggio dell'anello interno.	Sono particolarmente indicati per condizioni di funzionamento con elevati carichi alternati, carichi d'urto.
	SR...- 2RS	15 ÷ 300	ACCIAIO SU ACCIAIO	SI	Snodo sferico radiale. Stesse caratteristiche della serie SR... dalla quale si differenzia per le guarnizioni striscianti a doppio labbro su entrambi i lati.	Dove non è possibile prevedere adeguata protezione con guarnizioni separate.
	SRC...	12 ÷ 320	ACCIAIO SU ACCIAIO	SI	Snodo sferico radiale. Gli anelli interno ed esterno sono temprati. L'anello esterno presenta una spaccatura assiale per il montaggio dell'anello interno. Si differenziano dalla serie SR per particolari prolungamenti cilindrici su ogni lato dell'anello interno in modo tale che il diametro del foro corrisponde sempre alla larghezza dell'anello interno. Sono stati realizzati soprattutto per soddisfare le norme DIN 24 338.	Per tutti i cilindri idraulici normalizzati secondo CETOP e norme DIN 24 333 e DIN 24 336, ISO 6020/1 e ISO 6022.
	SRC...- 2RS	20 ÷ 80	ACCIAIO SU ACCIAIO	SI	Snodo sferico radiale. Stesse caratteristiche della serie SR... (2RS) dalla quale si differenzia per particolari prolungamenti cilindrici su ogni lato dell'anello interno.	Come la serie SR... ma in particolar modo dove esiste la necessità di anelli distanziatori sui due lati dell'anello interno.
	SRB...	6 ÷ 30	CROMO DURO SU BRONZO SINTERIZZATO CON PTFE	NO	Snodo sferico radiale esente da manutenzione. Anello esterno in bronzo sinterizzato contenente PTFE. Anello interno temprato, con superficie di lavoro sottoposta a cromatura dura.	Particolarmente indicati per funzionamento con carichi unilaterali, costanti e senza sollecitazioni d'urto (es: apparecchi di sollevamento, snodi per stantuffi di cilindri idraulici, etc.).
	SRT...- 2RS	17 ÷ 300	CROMO DURO SU TESSUTO PTFE	NO	Snodo sferico radiale esente da manutenzione; anello esterno temprato e con superficie di lavoro di tessuto di PTFE. Anello interno temprato e con superficie di lavoro sottoposta a cromatura dura e con guarnizioni striscianti a doppio labbro su entrambi i lati.	Stesse applicazioni del tipo SRB... ma con prestazioni decisamente superiori, sono indicati per fortissimi carichi agenti in un solo senso (ad esempio nei bracci per gru).
	SRCT...	16 ÷ 320	CROMO DURO SU TESSUTO PTFE	NO	Snodo sferico radiale esente da manutenzione; anello esterno temprato e con superficie di lavoro di tessuto di PTFE. Anello interno temprato e con superficie di lavoro sottoposta a cromatura dura.	Stesse applicazioni del tipo SRT e con caratteristiche dimensionali uguali agli snodi SRC ma esente da manutenzione. Particolarmente indicati per forti carichi agenti in un solo senso (ad esempio bracci per gru).

	SRL...	6 ÷ 180	ACCIAIO SU ACCIAIO	SI	Snodo sferico radiale. Avente stesse caratteristiche del tipo SR... ma con l'anello interno più largo e il diametro esterno più grande: ciò consente un maggior angolo di ribaltamento.	Per applicazioni di snodi dove è richiesto un grande angolo di ribaltamento.
	SRL...- 2RS	17 ÷ 280	ACCIAIO SU ACCIAIO	SI	Snodo sferico radiale. Avente stesse caratteristiche del tipo SR...2RS con l'eccezione che l'anello interno è più largo e il diametro esterno più grande: ciò consente un maggior angolo di ribaltamento.	Come per la serie SR... ma in particolar modo dove esiste necessità di maggior angolo di ribaltamento.
	SRLB...	6 ÷ 30	CROMO DURO SU TESSUTO PTFE	NO	Snodo sferico radiale. Avente stesse caratteristiche del tipo SRB... ma con l'anello interno più largo e il diametro esterno più grande: ciò consente un maggior angolo di ribaltamento.	Come per la serie SRB... ma in particolar modo dove esiste necessità di maggior angolo di ribaltamento.
	SRLT...- 2RS	30 ÷ 280	CROMO DURO SU TESSUTO PTFE	NO	Snodo sferico radiale in acciaio per cuscinetti, spaccato, temprato e rettificato, con anello esterno avente superficie in tessuto PTFE e anello interno con superficie sottoposta a cromatura dura. Guarnizioni striscianti a doppio labbro su entrambi i lati.	Indicati per fortissimi carichi agenti in un solo senso in condizioni di funzionamento esente da manutenzione con necessità di un basso sforzo di attrito.
	SR...TGR	12 ÷ 90	ACCIAIO SU TESSUTO PTFE ACCIAIO INOX	NO	Snodo sferico radiale. Come la serie SRLT... ma senza guarnizioni. Ambedue gli anelli dello snodo sono in acciaio inossidabile temprato, e la superficie di lavoro dell'anello interno è lucidata.	Per applicazioni di snodi in ambiente corrosivo.
	SR...TG3A-2RS	25 ÷ 300	ACCIAIO SU TESSUTO PTFE ACCIAIO INOX	NO	Snodo sferico radiale come la serie TGR, ma con anello esterno in due parti tenute assieme da apposito dispositivo di bloccaggio. Dotati di guarnizioni striscianti a doppio labbro su entrambi i lati.	Particolarmente indicati per applicazioni di snodi dove non si può prevedere una adeguata protezione con guarnizioni separate.
	SR...ZO	12 ÷ 152	ACCIAIO SU ACCIAIO	SI	Snodi sferici radiali. Stesse caratteristiche degli snodi SR... ma con dimensioni in pollici.	Sono particolarmente indicati per condizioni di funzionamento con elevati carichi alternati, carichi d'urto.
	SR...ZO-2RS	19 ÷ 88	ACCIAIO SU ACCIAIO	SI	Snodi sferici radiali. Stesse caratteristiche degli snodi SR...- 2RS ma con dimensioni in pollici.	Dove non è possibile prevedere adeguata protezione con guarnizioni separate.
	SR...SX	25 ÷ 240	ACCIAIO SU ACCIAIO	SI	Snodo sferico a contatto obliquo. Gli anelli esterno ed interno che lo compongono sono in acciaio temprato.	Adatti per carichi dinamici mutevoli. Vengono utilizzati quando i carichi in relazione a piccoli angoli di oscillazione portano ad una perdita nel cuscinetto.
	SR...SW	25 ÷ 300	CROMO DURO SU PTFE	NO	Snodo sferico a contatto obliquo senza manutenzione. Anello esterno temprato e con superficie di lavoro in PTFE. Anello interno temprato con superficie di lavoro sottoposta a cromatura dura.	Adatti per carichi combinati radiali e assiali agenti in un solo senso in condizioni di funzionamento esente da manutenzione con necessità di un basso sforzo di attrito; due snodi a contatto obliquo montati in coppia contrapposti, possono sopportare carichi assiali in entrambi i sensi.
	SR...AX	10 ÷ 200	ACCIAIO SU ACCIAIO	SI	Snodo sferico assiale. Gli anelli esterno ed interno che lo compongono sono in acciaio temprato.	Adatti per sopportare forze assiali e radiali, carichi verticali nella costruzione di congiunzione. Come cuscinetto radiale è alternativo per cuscinetti a rulli conici della serie 320 per DIN 720. Trasmettono movimenti e potenza in modo istantaneo e tengono distanziati gli elementi di costruzione attraverso sollecitazione di flessione.
	SR...AW	10 ÷ 360	CROMO DURO SU PTFE	NO	Snodo sferico assiale senza manutenzione. Anello esterno temprato e con superficie di lavoro in PTFE. Anello interno temprato con superficie di lavoro sottoposta a cromatura dura.	Adatti per carichi assiali agenti in un solo senso o carichi combinati radiali e assiali in condizioni di funzionamento esente da manutenzione con necessità di un basso sforzo di attrito. Possono essere accoppiati con snodi radiali per reggere carichi combinati radiali e assiali.



# LSP - Pavarini Components spherical plain bearings

## OPERATING, MOUNTING AND MAINTENANCE INSTRUCTIONS

### MOUNTING

Mounting operations of spherical plain bearings must be made according to the next instructions.

Cleanliness, skill by strictly following the instructions and the correct matchings when mounting are necessary to ensure good performance and suitable lifetime of spherical plain bearings.

In order to prevent spherical plain bearings getting dirty, you need to take them from their original packages immediately before the mounting.

Be aware that these spherical plain bearings should not come into contact with chemicals ( oil, solvents, detergents etc...) which may damage the operating surfaces of the bearing.

Any components which have possibly become dirty should be wiped using a clean and dry cloth.

The components associated with the bearings (shafts, housings etc...), must be cleaned, burr free and checked with regard to accuracy of dimensions.

While mounting, we suggest to keep interference in the relevant housings and to keep the recommended matching tolerances (TAB.1).

When mounting spherical plain bearings with a fractured or two-part outer ring, it is essential that the joint should be positioned at 90° (right angles) to the main direction of the load as otherwise the service lifetime will be shortened (PIC.1).

In order to mount spherical plain bearings correctly the use of a press is needed to ensure a perfect alignment between the axis of the spherical plain bearing and the axis of the housing.

Spherical plain bearings should not be hit by a hammer or drift, since the rings can easily be damaged and the service life of the spherical plain bearing drastically shortened.

(PIC.2).

### RECOMMENDED MATCHING TOLERANCES

To perform correctly spherical plain bearings need the following matching tolerances.

TAB.1

<b>Radial spherical plain bearings</b> matching steel on steel	M7/m6 for steel housing N7/m6 for alloy housing
<b>Radial spherical plain bearings</b> matching steel on PTFE	K7/m6 for steel housing M7/k6 for alloy housing
<b>Angular Contact spherical plain bearings</b> matching steel on steel matching steel on PTFE	M7/m6
<b>Axial spherical plain bearings</b> matching steel on steel matching steel on PTFE	J7/m6
In order to facilitate spherical plain bearings mounting and the dismantling step, we suggest to plan chamfers of 10°- 20° on housing and pin edges.	

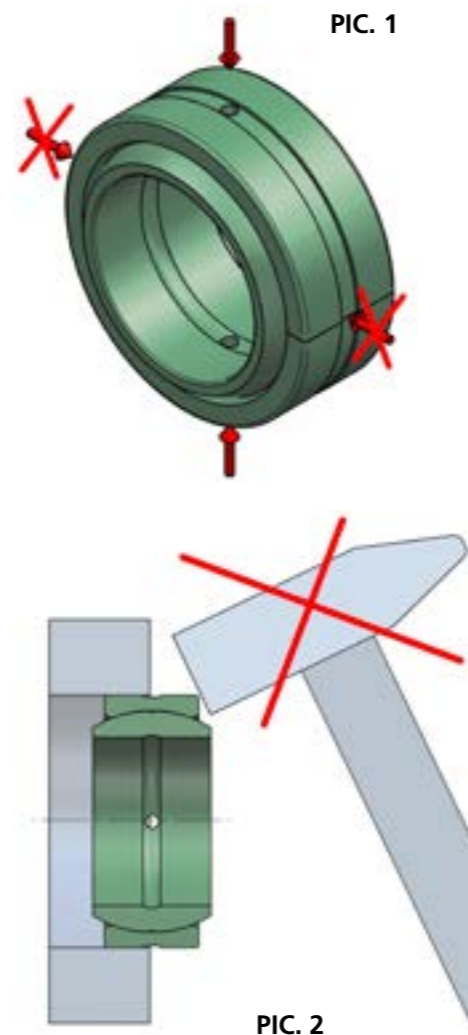

To mount spherical plain bearings it is recommended a mounting dolly, which should push only the ring that is forced whether onto a shaft (PIC.3) or into a housing (PIC.4).

When mounting simultaneously on the shaft and in the housing a dolly having two abutment surfaces should be used (PIC.5). The mounting force must never be directed through the operating sliding surfaces of the spherical plain bearing (contact surface between outer ring and inner ring). (PIC.6 e PIC.7)

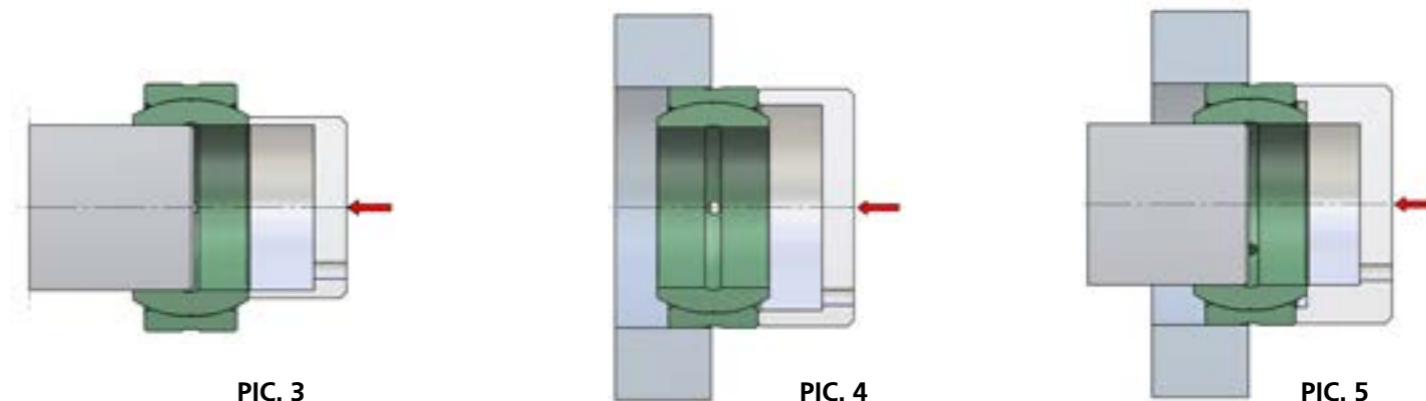

In case of a pre-heating of the spherical plain bearings is needed to facilitate the mounting onto a shaft, it is very important that the bearings should never be heated to temperatures above 110°C. As far as spherical plain bearings with -2RS seal is concerned, they should never be heated to temperatures above 90°C.

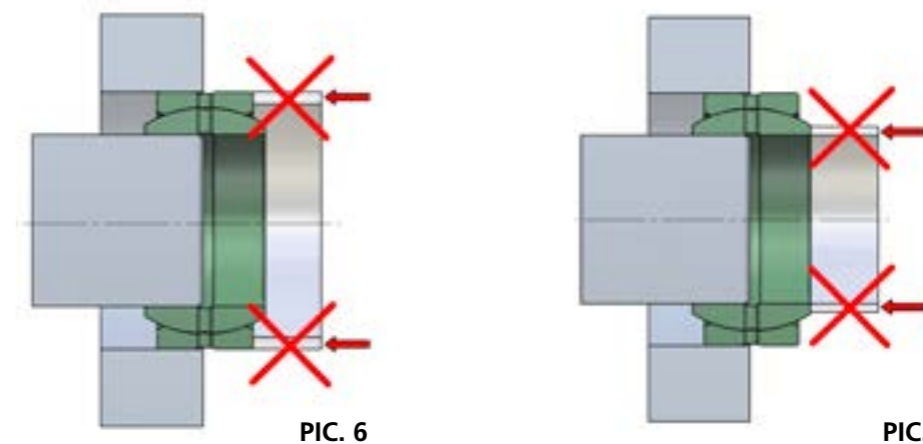

**To ensure the operating characteristics, we highly recommend to protect the bearings surfaces (outer ring, inner ring, seals) from painting.**

The service lifetime of spherical plain bearings could be shortened in case of not following this suggestion. Improper mountings do shorten the service life of spherical plain bearings and are the major part of the operating problems. (for instance: too much forced matching between spherical plain bearing and housing; unsuitable mounting tools, excessive applied force for mounting).

Regular sliding between inner ring and outer ring should occur after mounting. For such purpose the inner ring must be integral with the axis, while the outer ring must be integral with the housing where is mounted.

## INNER CLEARANCE

### Radial clearance

Radial clearance is the max. possible radial displacement of the inner ring by means of a certain load towards the housing of the outer ring

### Axial clearance

Axial clearance is the max. possible axial displacement of the inner ring by means of a certain load from one side to the opposite one, by keeping steady the position of the outer ring.

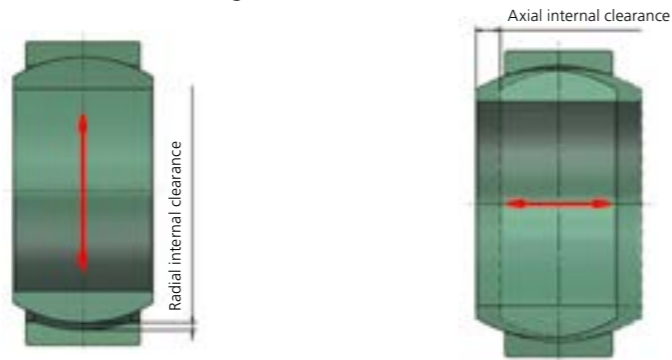

## LUBRICATION

### Spherical plain bearings requiring maintenance:

Spherical plain bearings which are steel-on-steel type require a suitable maintenance and lubrication.

The lubricant has the purpose to reduce wear, reduce friction and prevent scuffing. In addition to that the lubricant gives protection to the bearings against corrosion.

LSP steel-on-steel spherical plain bearings have sliding contact surfaces which are phosphated and treated with a 'running-in' lubricant.

It is highly recommended that the steel-on-steel bearings must be lubricated initially and then regularly relubricated, so that the old lubricant residuals will be removed and any possible impurities may spill out.

The choice about the lubricant type is made by taking into account the operating conditions of spherical plain bearings. As general application fields, we recommend greases based on lithium soap with additives EP and solid lubricant substances.

All steel-on-steel bearings have lubrication holes and an annular groove in the outer as well as in the inner ring so that the lubricant can be distributed thoroughly in the spherical plain bearing. An adequate supply of grease directly to the bearing is necessary. This can be done by providing ducts in the housing and a grease nipple (PIC. 8) or in the shaft or pin (PIC. 9).

In order to implement the corrosion protection while keeping in stock, spherical plain bearings are coated by grease.

**Warning: do not touch this type of grease with bare hands; allergenic or other type of skin soreness may occur.**

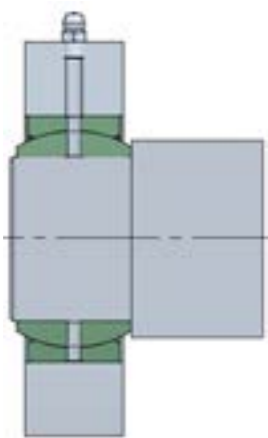

PIC. 8

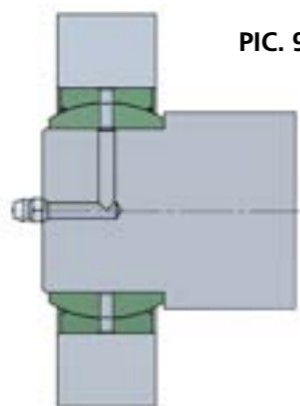

PIC. 9

### Maintenance-free Spherical plain bearings:

Maintenance-free spherical plain bearings are provided with special sliding layers composed of materials based on PTFE (polytetrafluoroethylene). Thanks to their peculiarity, as very low friction rate, these materials allow regular performances without any lubrication.

These bearings are used in those applications where long-lasting performances without any maintenance are needed or where the usage of steel-on-steel bearings is not recommended due to partial or completely impossible maintenance operation.

Maintenance-free bearings are available in two combinations of operation surfaces based on dimensions and type of material of the outer ring. The inner ring of both configurations is composed of chromium steel, tempered and with hard chromium plated sliding surface.

The outer ring of the bearings (with suffix= B) is composed of steel with a sinter bronze bushing having PTFE composite. Such a bushing is then pressed on the internal part of the ring (PIC 10).

The outer ring of the bearings (with suffix = T) is composed of chromium tempered steel. In the inner side of the outer ring high quality PTFE fabric (which guarantees high load performance) is glued on (PIC 11).

Any lubrication of the sliding contact surfaces is not advisable for these bearings, since it would disturb the transfer of PTFE particles from the outer ring to the opposing steel surface of the inner ring.

Therefore no lubrication is necessary.

In order to implement the corrosion protection while keeping in stock, spherical plain bearings are coated with a preservative oil.

**Warning: do not touch this type of oil with bare hands; allergenic or other type of skin soreness may occur.**

Sinter Bronze-PTFE

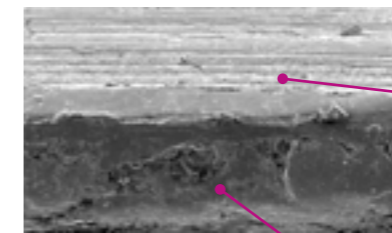

PIC. 10

Sinter Bronze

Steel-PTFE Fabric

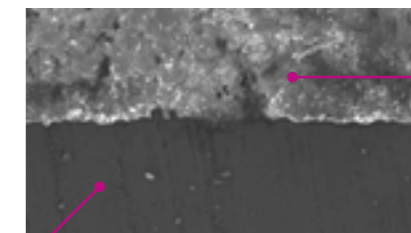

PIC. 11

Steel

PTFE Fabric

## PROTECTIONS

In case of heavy working conditions (dust, particles, etc...) these bearings are also provided with seals on both sides of the outer ring 2RS. These are lip-seals made of thermoplastic material. They can be used from -30°C up to +110°C. The seals of LSP spherical plain bearings can be recognized by the colour Pantone 297 (PIC.12).



## DISMOUNTING

Like for the mounting step, the requisite withdrawal force should always be applied to the forced ring. Then it is recommended to use a dolly as a tool that will push as pictured in (PIC.13)

A mechanical puller can be used for removing small bearings from shafts. The claws are applied directly to the bearing inner ring or to a component immediately behind the bearing (PIC.14)

If the bearings are to be re-used after dismantling the same care and attention are required as when mounting.

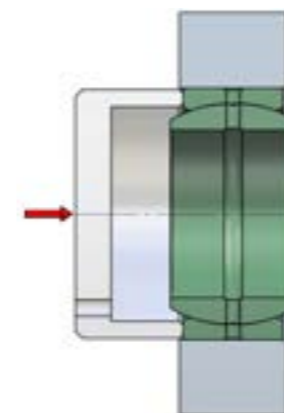

PIC. 13

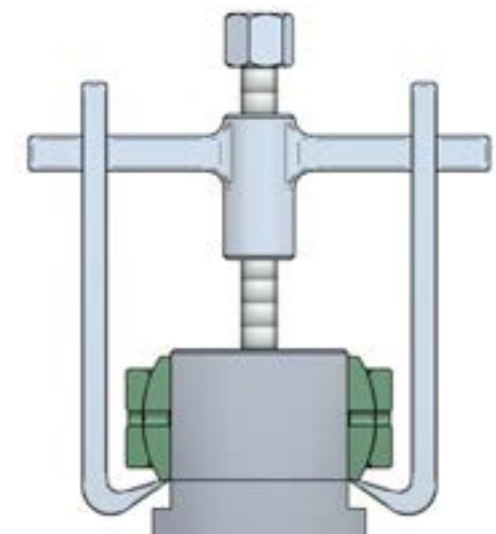

PIC. 14

# RADIAL AND AXIAL SPHERICAL PLAIN BEARING - LSP

Divided into two categories.







**a) Bearings requiring maintenance**











**b) Bearings not needing maintenance**

• THE GIVEN LOAD FACTOR REFERS ONLY TO "PAVARINI" SPHERICAL PLAIN BEARING "LSP" BRAND

- a) Belonging to the first category with steel grooves on steel. They are particularly recommended for use with loads which move in alternate directions, for dynamic and impact loads, and also strong static loads. Spherical bearings are included in this category: their field of application is hydraulic cylinders, useful in situations of heavy radial loads. Bearings with a surface of steel on steel must be regularly relubricated to guarantee correct functioning and a sufficient lifespan. To this end they are produced in series, with the exception of a few types of small dimensions, with grooves on the circumference and lubrication bore holes on the internal and external rings.
- b) The bearings not needing maintenance are produced with special layers of grooves composed of materials having a base of PTFE (polytetrafluoroethylene). These materials have been produced very recently and, thanks to their properties, such as a very low friction factor, permit regular functioning without lubrication. Their field of use is in all applications where longlasting use is required without maintenance or where the use of joints with steel on steel surfaces is not recommended above all for loads moving in a single direction or with slow movements.

**PRODUCT RANGE**

SPHERICAL BEARING	TYPE	HOLE DIAMETER (mm)	SLIDING CONTACT SURFACES	LUBRICATION REQUIRING ELEMENTS	DESIGN FEATURES	FIELD OF APPLICATION
	SR...	5 ÷ 300	STEEL/STEEL	YES	Spherical Bearings. The component internal and external rings are tempered. The external ring presents an axial split for assembly of the internal ring.	They are particularly recommended for operating conditions with alternating High-Loads, Impact Loads.
	SR...-2RS	15 ÷ 300	STEEL/STEEL	YES	Spherical Bearings. The same characteristics as the SR series, except for the grooved seals with a double lip on both sides.	It is not possible to make provision for adequate protection with separate gaskets.
	SRC...	12 ÷ 320	STEEL/STEEL	YES	Spherical Bearings. The internal and external rings are tempered. The external rings present an axial split for assembly of the internal ring. They differ from the SR series in the cylindrical extensions on every side of the internal ring in such a way the diameter of the bore always corresponds to the width of the internal ring. They were designed above all to adhere to regulation DIN24388.	For all hydraulic cylinders manufactured according to CETOP and regulation DIN 24333, DIN 24336, ISO 6020/1 and ISO6022.
	SRC...-2RS	20 ÷ 80	STEEL/STEEL	YES	Spherical Bearings. Having the same characteristics as the SR...-2RS type with the exception of the cylindrical extensions on every side of the internal ring.	Like the SR... series, particularly recommended where spacer sleeves on both sides of the internal ring are required.
	SRB...	6 ÷ 30	HARD CHROMIUM/ BRONZE WITH PTFE	NO	Spherical Bearings. Maintenance free. External ring in bronze containing PTFE. Internal ring tempered, with working surface hard chrome plated.	Particularly recommended for operation with Uniform Loads, constant and without shock stress (especially lifting apparatus, piston rods for hydraulics cylinders, etc.)
	SRT...-2RS	17 ÷ 300	HARD CHROMIUM/ PTFE	NO	Radial Bearings. Maintenance free. The external ring is tempered with working surfaces in PTFE material. The internal ring is tempered with working surfaces subjected to hard chrome and with grooved seals with a double lip on each side.	Same applications as the SRB type, but with a decidedly superior performance, they are therefore recommended for very heavy loads moving in a single direction (eg. The arms of a crane).
	SRCT...	16 ÷ 320	HARD CHROMIUM/ PTFE	NO	Radial spherical Bearings. Maintenance free. The external ring is tempered with working surfaces in PTFE material. The internal ring is tempered with working surfaces subjected to hard chrome.	Same applications as the SRT type, and with dimensional characteristics as SRC series but maintenance free. Particularly recommended for very heavy loads moving in a single direction (eg. The arms of a crane).

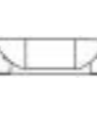
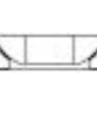
	SRL...	6 ÷ 180	STEEL/STEEL	YES	Spherical Bearings having the same characteristics as the SR... type but with the internal ring is larger and the external diameter is bigger; to have a greater turning angle.	Particularly recommended for applications where a greater turning angle is required.
	SRL...-2RS	17 ÷ 280	STEEL/STEEL	YES	Spherical Bearings. having the same characteristics as the SR...-2RS type with the exception of the internal ring which is wider and the external diameter is greater; allows a greater turning angle.	Like the SR series but with a need for a greater turning angle
	SRLB...	6 ÷ 30	HARD CHROMIUM/ PTFE	NO	Spherical Bearings having the same characteristics as the SRB... type with the exception of the internal ring which is wider and the external diameter is greater allowing a greater turning angle.	Like the SRB series but with a need for a greater turning angle.
	SRLT...-2RS	30 ÷ 280	HARD CHROMIUM/ PTFE	NO	Spherical Bearings in steel, split, tempered and ground all over. The external ring having working surfaces in PTFE material and internal ring is hard chrome. Grooved seals with a double lip on each side.	They are recommended for very heavy loads moving in a single direction in operating conditions where maintenance free is necessary.
	SR...TGR	12 ÷ 90	STEEL/PTFE STAINLESS STEEL	NO	Spherical Bearings like the SRLT... series but without grooved seal. The rings are made in stainless steel, tempered with working surfaces of the internal ring is buffed.	Particularly recommended in corrosive work environments.
	SR...TG3A-2RS	25 ÷ 300	STEEL/PTFE STAINLESS STEEL	NO	Spherical Bearings like the TGR... with the internal ring divided in two parts, joined by a locking system. Grooved seals with a double lip on each side.	Particularly recommended in corrosive work environments.
	SR...ZO	12 ÷ 152	STEEL/STEEL	YES	Spherical Bearings. The same characteristics as the SR...-2RS series but with dimension in inches.	They are recommended for operating conditions with alternating high impact loads.
	SR...ZO-2RS	19 ÷ 88	STEEL/STEEL	YES	Spherical Bearings. The same characteristics as the SR...-2RS series but with dimension in inches.	It is not possible to make provision for adequate protection with separate seals.
	SR...SX	25 ÷ 240	STEEL/STEEL	YES	Angular contact spherical plain bearings. The component internal and external rings are in tempered steel.	Used, where loads acting in conjunction with small swivee angles would damage rolling element bearings.
	SR...SW	25 ÷ 300	HARD CHROMIUM/ PTFE	NO	Angular contact spherical plain bearings maintenance free. The external ring is tempered with working surfaces in PTFE material. The internal ring is tempered with working surfaces subjected to hard chrome.	Used where high loads acting in conjunction with little movement be supported.
	SR...AX	10 ÷ 200	STEEL/STEEL	YES	Axial spherical plain bearings. The component internal and external rings are in tempered steel.	They can transmit movement-free support load into the adjacent construction.
	SR...AW	10 ÷ 360	HARD CHROMIUM/ PTFE	NO	Axial spherical plain bearings maintenance free. The external ring is tempered with working surface in PTFE material. The internal ring is tempered with working surfaces subjected to hard chrome.	They are a plain bearing alternative to taper roller bearings

**SR...**  
**SR... - 2RS**  
 (GE...E; GE...ES; GE...ES-2RS; GE...DO; GE...DO-2RS)

SNODI SFERICI RADIALI  
 ISO 12240-1 SERIE E  
 RICHIEDENTI MANUTENZIONE  
 ACCOPPIAMENTO : ACCIAIO SU ACCIAIO

SPHERICAL PLAIN BEARING  
 ISO 12240-1 SERIES E  
 REQUIRING MAINTENANCE  
 COUPLING:STEEL/STEEL

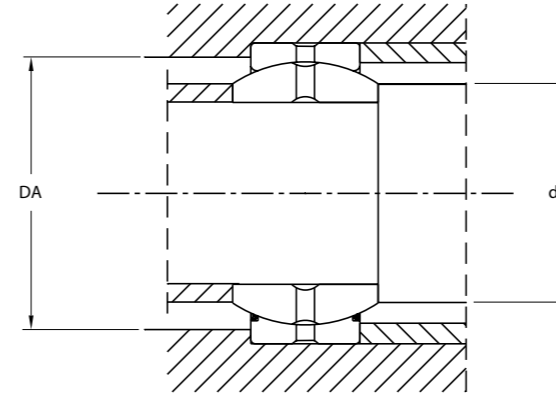
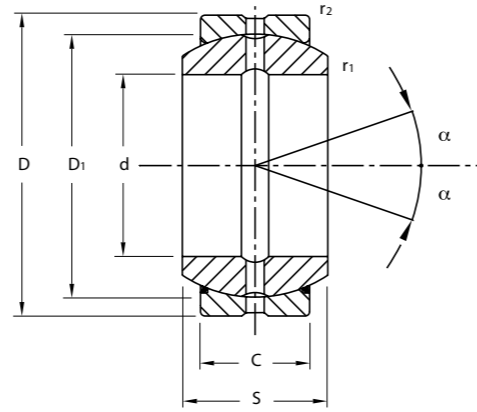

SIGLA CUSCINETTO SENZA TENUTA BEARING WITHOUT PROTECTION RINGS	SIGLA CUSCINETTO CON TENUTA BEARING WITH PROTECTION RINGS	d	D	S	C	TOLLERANZA TOLERANCE				r1	r2
						d	D	S	C		
mm.											
SR 5 (1)		5	14	6	4	0 + -0.008	0 + -0.008	0 + -0.12	0 + -0.24	0.3	0.3
SR 6 (1)		6	14	6	4	0 + -0.008	0 + -0.008	0 + -0.12	0 + -0.24	0.3	0.3
SR 8 (1)		8	16	8	5	0 + -0.008	0 + -0.008	0 + -0.12	0 + -0.24	0.3	0.3
SR 10 (1)		10	19	9	6	0 + -0.008	0 + -0.009	0 + -0.12	0 + -0.24	0.3	0.3
SR 12 (1)		12	22	10	7	0 + -0.008	0 + -0.009	0 + -0.12	0 + -0.24	0.3	0.3
SR 15	SR 15-2RS	15	26	12	9	0 + -0.008	0 + -0.009	0 + -0.12	0 + -0.24	0.3	0.3
SR 16 (A)		16	30	14	10	0 + -0.008	0 + -0.009	0 + -0.12	0 + -0.24	0.3	0.3
SR 17	SR 17-2RS	17	30	14	10	0 + -0.008	0 + -0.009	0 + -0.12	0 + -0.24	0.3	0.3
SR 20	SR 20-2RS	20	35	16	12	0 + -0.010	0 + -0.011	0 + -0.12	0 + -0.24	0.6	0.3
SR 25	SR 25-2RS	25	42	20	16	0 + -0.010	0 + -0.011	0 + -0.12	0 + -0.24	0.6	0.6
SR 30	SR 30-2RS	30	47	22	18	0 + -0.010	0 + -0.011	0 + -0.12	0 + -0.24	0.6	0.6
SR 35	SR 35-2RS	35	55	25	20	0 + -0.012	0 + -0.013	0 + -0.12	0 + -0.30	0.6	1.0
SR 40	SR 40-2RS	40	62	28	22	0 + -0.012	0 + -0.013	0 + -0.12	0 + -0.30	0.6	1.0
SR 45	SR 45-2RS	45	68	32	25	0 + -0.012	0 + -0.013	0 + -0.12	0 + -0.30	0.6	1.0
SR 50	SR 50-2RS	50	75	35	28	0 + -0.012	0 + -0.013	0 + -0.12	0 + -0.30	0.6	1.0
SR 60	SR 60-2RS	60	90	44	36	0 + -0.015	0 + -0.015	0 + -0.15	0 + -0.40	1.0	1.0
SR 70	SR 70-2RS	70	105	49	40	0 + -0.015	0 + -0.015	0 + -0.15	0 + -0.40	1.0	1.0
SR 80	SR 80-2RS	80	120	55	45	0 + -0.015	0 + -0.015	0 + -0.15	0 + -0.40	1.0	1.0
SR 90	SR 90-2RS	90	130	60	50	0 + -0.020	0 + -0.018	0 + -0.20	0 + -0.50	1.0	1.0
SR 100	SR 100-2RS	100	150	70	55	0 + -0.020	0 + -0.018	0 + -0.20	0 + -0.50	1.0	1.0
SR 110	SR 110-2RS	110	160	70	55	0 + -0.020	0 + -0.025	0 + -0.20	0 + -0.50	1.0	1.0
SR 120	SR 120-2RS	120	180	85	70	0 + -0.020	0 + -0.025	0 + -0.20	0 + -0.50	1.0	1.0
SR 140	SR 140-2RS	140	210	90	70	0 + -0.025	0 + -0.030	0 + -0.25	0 + -0.60	1.0	1.0
SR 160	SR 160-2RS	160	230	105	80	0 + -0.025	0 + -0.030	0 + -0.25	0 + -0.60	1.0	1.0
SR 180	SR 180-2RS	180	260	105	80	0 + -0.025	0 + -0.035	0 + -0.25	0 + -0.70	1.1	1.1
SR 200 (2)	SR 200-2RS	200	290	130	100	0 + -0.030	0 + -0.035	0 + -0.30	0 + -0.70	1.1	1.1
SR 220 (2)	SR 220-2RS (2)	220	320	135	100	0 + -0.030	0 + -0.040	0 + -0.30	0 + -0.80	1.1	1.1
SR 240 (2)	SR 240-2RS (2)	240	340	140	100	0 + -0.030	0 + -0.040	0 + -0.30	0 + -0.80	1.1	1.1
SR 260 (2)	SR 260-2RS (2)	260	370	150	110	0 + -0.035	0 + -0.040	0 + -0.35	0 + -0.80	1.1	1.1
SR 280 (2)	SR 280-2RS (2)	280	400	155	120	0 + -0.035	0 + -0.040	0 + -0.35	0 + -0.80	1.1	1.1
SR 300 (2)	SR 300-2RS (2)	300	430	165	120	0 + -0.035	0 + -0.045	0 + -0.35	0 + -0.90	1.1	1.1

(1) NON RILUBRIFICABILE  
 (2) DISPONIBILITA' E PREZZO A RICHIESTA  
**NOTA:** PER EVITARE IL DANNEGGIAMENTO O LA PERDITA DELLE PROTEZIONI (-2RS) E' NECESSARIO IMPEDIRE ALL'ANELLO INTERNO DI RUOTARE AL DI FUORI DELL'ANELLO ESTERNO. TALE AVVERTENZA SI RIFERISCE IN PARTICOLARE MODO AGLI SNODI CON ANELLO ESTERNO DIVISO IN DUE METÀ; TENUTE INSIEME MEDIANTE UN NASTRO DI ACCIAIO.

(1) WITHOUT GREASE NIPPLE  
 (2) AVAILABILITY AND PRICE UPON REQUEST  
**NOTES:** TO AVOID THE DAMAGE OR THE LOSS OF THE PROTECTION RINGS(-2RS) DO NOT ALLOW INNER BALL TO ROTATE OUT OF THE EXTERNAL HOUSING.

(A) FUORI NORMATIVA - OUT OF STANDARD

d	D1	ANGOLO DI OSCILLAZIONE α SWINGING ANGLE α	FATTORI DI CARICO LIMITE LOAD FACTORS		GIUOCO RADIALE RADIAL CLEARANCE	r1	r2	DIMENSIONI DI MONTAGGIO MOUNTING DIMENSIONS		PESO IN Kg. WEIGHT Kg.
			Dinamico Dynamic	Statico Static				da max.	DA min.	
mm.		α°	KN		mm.		Kg.			
5	10	16	3.4	17	0.032 - 0.068	0.3	0.3	8	9.5	0.004
6	10	13	3.4	17	0.032 - 0.068	0.3	0.3	8	9.6	0.006
8	13	15	5.5	27.5	0.032 - 0.068	0.3	0.3	10.2	12.5	0.008
10	16	12	8.15	40.5	0.032 - 0.068	0.3	0.3	13.2	15.5	0.01
12	18	11	10.8	54	0.032 - 0.068	0.3	0.3	14.9	17.5	0.01
15	22	8	17	85	0.040 - 0.082	0.3	0.3	18.4	21	0.02
16	25	10	21.2	106	0.040 - 0.082	0.3	0.3	20.7	24	0.03
17	25	10	21.2	106	0.040 - 0.082	0.3	0.3	20.7	24	0.04
20	29	9	30	146	0.040 - 0.082	0.6	0.3	24.1	27.5	0.06
25	35.5	7	48	240	0.050 - 0.100	0.6	0.6	29.3	33	0.11
30	40.7	6	62	310	0.050 - 0.100	0.6	0.6	34.2	38	0.14
35	47	6	80	400	0.050 - 0.100	0.6	1.0	39.7	44.5	0.22
40	53	7	100	500	0.060 - 0.120	0.6	1.0	45	51	0.30
45	60	7	127	640	0.060 - 0.120	0.6	1.0	50.7	57	0.40
50	66	6	156	780	0.060 - 0.120	0.6	1.0	55.9	63	0.54
60	80	6	245	1220	0.060 - 0.120	1.0	1.0	66.8	75	1.00
70	92	6	315	1560	0.072 - 0.142	1.0	1.0	77.8	87	1.50
80	105	6	400	2000	0.072 - 0.142	1.0	1.0	89.4	99	2.20
90	115	5	490	2450	0.072 - 0.142	1.0	1.0	98.1	108	2.70
100	130	7	610	3050	0.085 - 0.165	1.0	1.0	109.5	123	4.30
110	140	6	655	3250	0.085 - 0.165	1.0	1.0	121.2	134	4.70
120	160	6	950	4750	0.085 - 0.165	1.0	1.0	135.5	150	8.00
140	180	7	1080	5400	0.085 - 0.165	1.0	1.0	155.8	173	11.00
160	200	8	1370	6800	0.100 - 0.192	1.0	1.0	170.2	191	13.50
180	225	6	1530	7650	0.100 - 0.192	1.1	1.1	198.9	219	18.50
200	250	7	2120	10600	0.100 - 0.192	1.1	1.1	213.5	239	28.00
220	275	8	2320	11600	0.100 - 0.192	1.1	1.1	239.5	267	35.50
240	300	8	2550	12700	0.100 - 0.192	1.1	1.1	265.3	295	40.00
260	325	7	3050	15300	0.110 - 0.214	1.1	1.1	288.3	319	50.00
280	350	6	3550	18000	0.110 - 0.214	1.1	1.1	313.8	342	64.00
300	375	7	3800	19000	0.110 - 0.214	1.1	1.1	336.7	370	75.00

**SRC...**

(GEG...ES; GE...LO; GEEW...ES)

SNODI SFERICI RADIALI  
ISO 12240-1 SERIE W  
RICHIEDENTI MANUTENZIONE  
ACCOPIAMENTO : ACCIAIO SU ACCIAIO

SPHERICAL PLAIN BEARING  
ISO 12240-1 SERIES W  
REQUIRING MAINTENANCE  
COUPLING:STEEL/STEEL

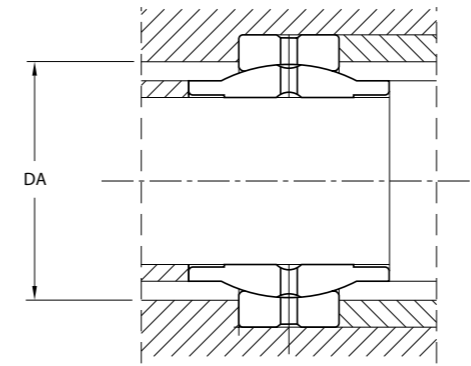
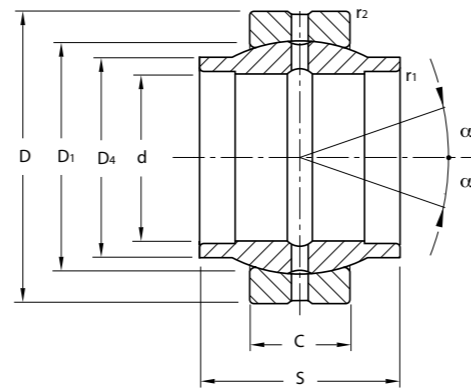

SIGLA ARTICLE	d	D	S	C	TOLLERANZA TOLERANCE				r1	r2
					d	D	S	C		
	mm.									
SRC 12 (1)	12	22	12	7	0 + +0.018	0 + -0.009	0 + -0.18	0 + -0.24	0.3	0.3
SRC 16	16	28	16	9	0 + +0.018	0 + -0.009	0 + -0.18	0 + -0.24	0.3	0.3
SRC 20	20	35	20	12	0 + +0.021	0 + -0.011	0 + -0.21	0 + -0.24	0.3	0.3
SRC 25	25	42	25	16	0 + +0.021	0 + -0.011	0 + -0.21	0 + -0.24	0.6	0.6
SRC 32	32	52	32	18	0 + +0.025	0 + -0.013	0 + -0.25	0 + -0.30	0.6	1.0
SRC 40	40	62	40	22	0 + +0.025	0 + -0.013	0 + -0.25	0 + -0.30	0.6	1.0
SRC 50	50	75	50	28	0 + +0.025	0 + -0.013	0 + -0.25	0 + -0.30	0.6	1.0
SRC 63	63	95	63	36	0 + +0.030	0 + -0.015	0 + -0.30	0 + -0.40	1.0	1.0
SRC 70	70	105	70	40	0 + +0.030	0 + -0.015	0 + -0.30	0 + -0.40	1.0	1.0
SRC 80	80	120	80	45	0 + +0.030	0 + -0.015	0 + -0.30	0 + -0.40	1.0	1.0
SRC 90	90	130	90	50	0 + +0.035	0 + -0.018	0 + -0.35	0 + -0.50	1.0	1.0
SRC 100	100	150	100	55	0 + +0.035	0 + -0.018	0 + -0.35	0 + -0.50	1.0	1.0
SRC 110	110	160	110	55	0 + +0.035	0 + -0.025	0 + -0.35	0 + -0.50	1.0	1.0
SRC 125	125	180	125	70	0 + +0.040	0 + -0.025	0 + -0.40	0 + -0.50	1.0	1.0
SRC 160	160	230	160	80	0 + +0.040	0 + -0.030	0 + -0.40	0 + -0.60	1.0	1.0
SRC 200	200	290	200	100	0 + +0.046	0 + -0.035	0 + -0.46	0 + -0.70	1.1	1.1
SRC 250 (2)	250	400	250	120	0 + +0.046	0 + -0.040	0 + -0.46	0 + -0.80	1.1	1.1
SRC 320 (2)	320	520	320	160	0 + +0.057	0 + -0.050	0 + -0.57	0 + -0.90	1.1	1.1

(1) NON RILUBRIFICABILE  
(2) DISPONIBILITA' E PREZZO A RICHIESTA

(1) WITHOUT GREASE NIPPLE  
(2) AVAILABILITY AND PRICE UPON REQUEST

d	D1	D4	ANGOLO DI OSCILLAZIONE $\alpha$ SWINGING ANGLE $\alpha$	FATTORI DI CARICO LIMITE LOAD FACTORS		GIUOCO RADIALE RADIAL CLEARANCE	DIMENSIONI DI MONTAGGIO MOUNTING DIMENSIONS DA min.	PESO IN Kg WEIGHT Kg.
				Dinamico Dynamic C	Statico Static Co			
	mm.		$\alpha^\circ$	KN		mm.	Kg.	
12	18	15.5	4	10.8	54	0.032 - 0.068	17.5	0.02
16	23	20	4	17.6	88	0.040 - 0.082	23	0.03
20	29	25	4	30	146	0.040 - 0.082	27.5	0.07
25	35.5	30.5	4	48	240	0.050 - 0.100	33	0.12
32	44	38	4	67	335	0.050 - 0.100	42	0.20
40	53	46	4	100	500	0.060 - 0.120	51	0.34
50	66	57	4	156	780	0.060 - 0.120	63	0.56
63	83	71.5	4	255	1270	0.072 - 0.142	78	1.20
70	92	79	4	315	1560	0.072 - 0.142	87	1.70
80	105	91	4	400	2000	0.072 - 0.142	99	2.40
90	115	99	4	490	2450	0.072 - 0.142	108	3.20
100	130	113	4	610	3050	0.085 - 0.165	123	4.80
110	140	124	4	655	3250	0.085 - 0.165	134	5.80
125	160	138	4	950	4750	0.085 - 0.165	150	8.50
160	200	177	4	1370	6800	0.100 - 0.192	191	16.50
200	250	221	4	2120	10600	0.100 - 0.192	239	32.00
250	350	317	4	3750	18000	0.110 - 0.214	342	99.00
320	450	405	4	6200	30500	0.135 - 0.261	438	225.00

**SRC... - 2RS**  
(GEM...ES-2RS; GE...HO-2RS; GEEM...ES-2RS)

SNODI SFERICI RADIALI  
RICHIEDENTI MANUTENZIONE  
ACCOPIAMENTO : ACCIAIO SU ACCIAIO

SPHERICAL PLAIN BEARINGS  
REQUIRING MAINTENANCE  
COUPLING:STEEL/STEEL

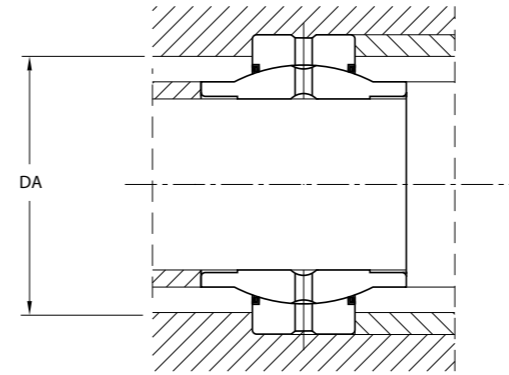
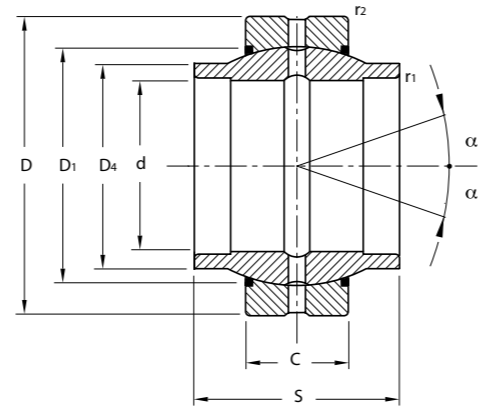

SIGLA ARTICLE	d	D	S	C	TOLLERANZA TOLERANCE				r1	r2
					d	D	S	C		
	mm.									
SRC 20- 2RS	20	35	24	12	0 + -0.010	0 + -0.011	± 0.2	0 + -0.24	0.2	0.3
SRC 25- 2RS	25	42	29	16	0 + -0.010	0 + -0.011	± 0.3	0 + -0.24	0.2	0.6
SRC 30- 2RS	30	47	30	18	0 + -0.010	0 + -0.011	± 0.3	0 + -0.24	0.2	0.6
SRC 35- 2RS	35	55	35	20	0 + -0.012	0 + -0.013	± 0.3	0 + -0.30	0.3	1.0
SRC 40- 2RS	40	62	38	22	0 + -0.012	0 + -0.013	± 0.3	0 + -0.30	0.3	1.0
SRC 45- 2RS	45	68	40	25	0 + -0.012	0 + -0.013	± 0.3	0 + -0.30	0.3	1.0
SRC 50- 2RS	50	75	43	28	0 + -0.012	0 + -0.013	± 0.3	0 + -0.30	0.3	1.0
SRC 60- 2RS	60	90	54	36	0 + -0.015	0 + -0.015	± 0.3	0 + -0.40	0.3	1.0
SRC 70- 2RS	70	105	65	40	0 + -0.015	0 + -0.015	± 0.3	0 + -0.40	0.3	1.0
SRC 80- 2RS	80	120	74	45	0 + -0.015	0 + -0.015	± 0.3	0 + -0.40	0.3	1.0

d	D1	D4	ANGOLO DI OSCILLAZIONE α SWINGING ANGLE α	FATTORI DI CARICO LIMITE LOAD FACTORS		GIUOCO RADIALE RADIAL CLEARANCE	DIMENSIONI DI MONTAGGIO MOUNTING DIMENSIONS DA min.	PESO IN Kg WEIGHT Kg.
				Dinamico Dynamic C	Statico Static Co			
	mm.		α°	KN		mm.	Kg.	
20	29	24	3	30	146	0.040 - 0.082	27.5	0.05
25	35.5	29	3	48	240	0.050 - 0.100	33	0.10
30	40.7	34.2	3	62	310	0.050 - 0.100	38	0.14
35	47	40	3	80	400	0.050 - 0.100	44.5	0.24
40	53	45	3	100	500	0.060 - 0.120	51	0.29
45	60	51.5	3	127	640	0.060 - 0.120	57	0.43
50	66	56.5	3	156	780	0.060 - 0.120	63	0.54
60	80	67.7	3	245	1220	0.060 - 0.120	75	1.10
70	92	78	3	315	1560	0.072 - 0.142	87	1.60
80	105	90	3	400	2000	0.072 - 0.142	99	2.40

**NOTA:** PER EVITARE IL DANNEGGIAMENTO O LA PERDITA DELLE PROTEZIONI (-2RS) E' NECESSARIO IMPEDIRE ALL'ANELLO INTERNO DI RUOTARE AL DI FUORI DELL'ANELLO ESTERNO. TALE AVVERTENZA SI RIFERISCE IN PARTICOLARE MODO AGLI SNODI CON ANELLO ESTERNO DIVISO IN DUE META', TENUTE INSIEME MEDIANTE UN NASTRO DI ACCIAIO.

**NOTES:** TO AVOID THE DAMAGE OR THE LOSS OF THE PROTECTION RINGS(-2RS) DO NOT ALLOW INNER BALL TO ROTATE OUT OF THE EXTERNAL HOUSING.

**SRL...**

**SRL... - 2RS**

(GEH...ES; GEH...ES-2RS; GE...FO; GE...FO-2RS; GEG...ES; GEG...ES-2RS)

SNODI SFERICI RADIALI  
ISO 12240-1 SERIE G  
RICHIEDENTI MANUTENZIONE  
ACCOPIAMENTO : ACCIAIO SU ACCIAIO

SPHERICAL PLAIN BEARINGS  
ISO 12240-1 SERIES G  
REQUIRING MAINTENANCE  
COUPLING:STEEL/STEEL

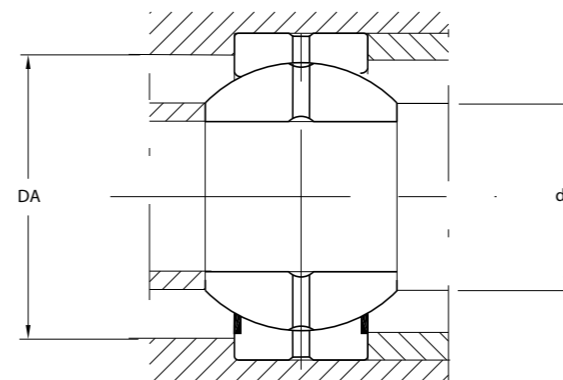
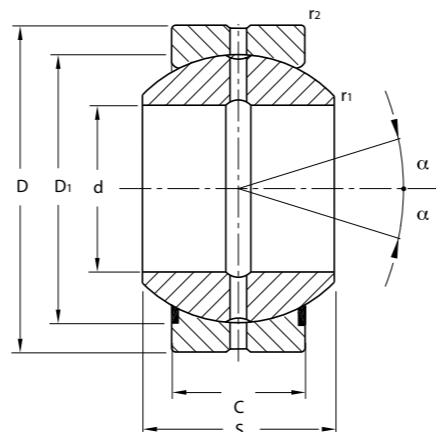

SIGLA CUSCINETTO SENZA TENUTA CODE BEARING WITHOUT PROTECTION RINGS	SIGLA CUSCINETTO CON TENUTA CODE BEARING WITH PROTECTION RINGS	d	D	S	C	TOLLERANZA TOLERANCE				r1	r2
						d	D	S	C		
mm.											
SRL 6 (1)(3)		6	16	9	5	0 +-0.008	0 +-0.008	0 +-0.12	0 +-0.24	0.3	0.3
SRL 8 (1)		8	19	11	6	0 +-0.008	0 +-0.009	0 +-0.12	0 +-0.24	0.3	0.3
SRL 10 (1)		10	22	12	7	0 +-0.008	0 +-0.009	0 +-0.12	0 +-0.24	0.3	0.3
SRL 12 (1)		12	26	15	9	0 +-0.008	0 +-0.009	0 +-0.12	0 +-0.24	0.3	0.3
SRL 15	SRL 15 - 2RS	15	30	16	10	0 +-0.008	0 +-0.009	0 +-0.12	0 +-0.24	0.3	0.3
SRL 17	SRL 17 - 2RS	17	35	20	12	0 +-0.008	0 +-0.011	0 +-0.12	0 +-0.24	0.3	0.3
SRL 20	SRL 20 - 2RS	20	42	25	16	0 +-0.010	0 +-0.011	0 +-0.12	0 +-0.24	0.6	0.6
SRL 25	SRL 25 - 2RS	25	47	28	18	0 +-0.010	0 +-0.011	0 +-0.12	0 +-0.24	0.6	0.6
SRL 30	SRL 30 - 2RS	30	55	32	20	0 +-0.010	0 +-0.013	0 +-0.12	0 +-0.30	0.6	1.0
SRL 35	SRL 35 - 2RS	35	62	35	22	0 +-0.012	0 +-0.013	0 +-0.12	0 +-0.30	0.6	1.0
SRL 40	SRL 40 - 2RS	40	68	40	25	0 +-0.012	0 +-0.013	0 +-0.12	0 +-0.30	0.6	1.0
SRL 45	SRL 45 - 2RS	45	75	43	28	0 +-0.012	0 +-0.013	0 +-0.12	0 +-0.30	0.6	1.0
SRL 50	SRL 50 - 2RS	50	90	56	36	0 +-0.012	0 +-0.015	0 +-0.15	0 +-0.40	0.6	1.0
SRL 60	SRL 60 - 2RS	60	105	63	40	0 +-0.015	0 +-0.015	0 +-0.15	0 +-0.40	1.0	1.0
SRL 70	SRL 70 - 2RS	70	120	70	45	0 +-0.015	0 +-0.015	0 +-0.15	0 +-0.40	1.0	1.0
SRL 80	SRL 80 - 2RS	80	130	75	50	0 +-0.015	0 +-0.018	0 +-0.20	0 +-0.50	1.0	1.0
SRL 90	SRL 90 - 2RS	90	150	85	55	0 +-0.020	0 +-0.018	0 +-0.20	0 +-0.50	1.0	1.0
SRL 100	SRL 100 - 2RS	100	160	85	55	0 +-0.020	0 +-0.025	0 +-0.20	0 +-0.50	1.0	1.0
SRL 110	SRL 110 - 2RS	110	180	100	70	0 +-0.020	0 +-0.025	0 +-0.20	0 +-0.50	1.0	1.0
SRL 120	SRL 120 - 2RS	120	210	115	70	0 +-0.020	0 +-0.030	0 +-0.25	0 +-0.60	1.0	1.0
SRL 140	SRL 140 - 2RS	140	230	130	80	0 +-0.025	0 +-0.030	0 +-0.25	0 +-0.60	1.0	1.0
SRL 160 (3)	SRL 160 - 2RS	160	260	135	80	0 +-0.025	0 +-0.035	0 +-0.25	0 +-0.70	1.0	1.1
SRL 180 (3)	SRL 180 - 2RS	180	290	155	100	0 +-0.025	0 +-0.035	0 +-0.30	0 +-0.70	1.1	1.1
	SRL 200 - 2RS (3)	200	320	165	100	0 +-0.030	0 +-0.040	0 +-0.30	0 +-0.80	1.1	1.1
	SRL 220 - 2RS (3)	220	340	175	100	0 +-0.030	0 +-0.040	0 +-0.30	0 +-0.80	1.1	1.1
	SRL 240 - 2RS (3)	240	370	190	110	0 +-0.030	0 +-0.040	0 +-0.35	0 +-0.80	1.1	1.1
	SRL 260 - 2RS (3)	260	400	205	120	0 +-0.035	0 +-0.040	0 +-0.35	0 +-0.80	1.1	1.1
	SRL 280 - 2RS (3)	280	430	210	120	0 +-0.035	0 +-0.045	0 +-0.35	0 +-0.90	1.1	1.1

d	D1	ANGOLO DI OSCILLAZIONE α SWINGING ANGLE α	FATTORI DI CARICO LIMITE LOAD FACTORS		GIUOCO RADIALE RADIAL CLEARANCE	r1	r2	DIMENSIONI DI MONTAGGIO MOUNTING DIMENSIONS		PESO IN Kg. WEIGHT Kg.
			Dinamico Dynamic	Statico Static				da max.	DA min.	
mm.										
α°										
KN										
mm.										
Kg.										
6	13	21	5.5	7.5	0.032 - 0.068	0.3	0.3	9.3	12.5	0.008
8	16	21	8.15	40.5	0.032 - 0.068	0.3	0.3	11.6	15.5	0.01
10	18	18	10.8	54	0.032 - 0.068	0.3	0.3	13.4	17.5	0.02
12	22	18	17	85	0.040 - 0.082	0.3	0.3	16	21	0.03
15	25	16	21.2	106	0.040 - 0.082	0.3	0.3	19.2	24	0.04
17	29	19	30	146	0.040 - 0.082	0.3	0.3	21	27.5	0.07
20	35.5	17	48	240	0.050 - 0.100	0.6	0.6	25.2	33	0.15
25	40.7	17	62	310	0.050 - 0.100	0.6	0.6	29.5	38	0.19
30	47	17	80	400	0.050 - 0.100	0.6	1.0	34.4	44.5	0.29
35	53	16	100	500	0.060 - 0.120	0.6	1.0	39.7	51	0.39
40	60	17	127	640	0.060 - 0.120	0.6	1.0	44.7	57	0.52
45	66	15	156	780	0.060 - 0.120	0.6	1.0	50	63	0.68
50	80	17	245	1220	0.060 - 0.120	0.6	1.0	57.1	75	1.40
60	92	17	315	1560	0.072 - 0.142	1.0	1.0	67	87	2.00
70	105	16	400	2000	0.072 - 0.142	1.0	1.0	78.2	99	2.90
80	115	14	490	2450	0.072 - 0.142	1.0	1.0	87.1	108	3.50
90	130	15	610	3050	0.085 - 0.165	1.0	1.0	98.3	123	5.40
100	140	14	655	3250	0.085 - 0.165	1.0	1.0	111.2	134	5.90
110	160	12	950	4750	0.085 - 0.165	1.0	1.0	124.8	150	9.70
120	180	16	1080	5400	0.085 - 0.165	1.0	1.0	138.4	173	15.00
140	200	16	1370	6800	0.100 - 0.192	1.0	1.0	151.9	191	18.50
160	225	16	1530	7650	0.100 - 0.192	1.0	1.1	180	219	25.00
180	250	14	2120	10600	0.100 - 0.192	1.1	1.1	196.1	239	35.50
200	275	15	2320	11600	0.100 - 0.192	1.1	1.1	220	267	45.00
220	300	16	2550	12700	0.100 - 0.192	1.1	1.1	243.6	295	51.00
240	325	15	3050	15300	0.110 - 0.214	1.1	1.1	263.6	319	64.00
260	350	15	3550	18000	0.110 - 0.214	1.1	1.1	283.6	342	81.00
280	375	15	3800	19000	0.110 - 0.214	1.1	1.1	310.6	370	94.00

- (1) NON RILUBRIFICABILE
- (2) RILUBRIFICABILE SOLO TRAMITE ANELLO ESTERNO
- (3) DISPONIBILITA' E PREZZO A RICHIESTA

**NOTA:** PER EVITARE IL DANNEGGIAMENTO O LA PERDITA DELLE PROTEZIONI (-2RS) E' NECESSARIO IMPEDIRE ALL'ANELLO INTERNO DI RUOTARE AL DI FUORI DELL'ANELLO ESTERNO. TALE AVVERTENZA SI RIFERISCE IN PARTICOLARE MODO AGLI SNODI CON ANELLO ESTERNO DIVISO IN DUE META', TENUTE INSIEME MEDIANTE UN NASTRO DI ACCIAIO.

- (1) WITHOUT GREASE NIPPLE
- (2) MAINTENANCE THROUGH EXTERNAL RING
- (3) AVAILABILITY AND PRICE UPON REQUEST

**NOTES:** TO AVOID THE DAMAGE OR THE LOSS OF THE PROTECTION RINGS(-2RS) DO NOT ALLOW INNER BALL TO ROTATE OUT OF THE EXTERNAL HOUSING.

richiedenti manutenzione/requiring maintenance

**SR...ZO**  
**SR...ZO - 2RS**  
 (GEZ...ES; GEZ...ES-2RS; GE...ZO; GE...ZO-2RS)

SNODI SFERICI RADIALI  
 CON DIMENSIONI IN POLLICI  
 RICHIEDENTI MANUTENZIONE  
 ACCOPPIAMENTO : ACCIAIO SU ACCIAIO  
 SPHERICAL PLAIN BEARINGS  
 WITH SIZES IN INCHES  
 REQUIRING MAINTENANCE  
 COUPLING: STEEL/STEEL

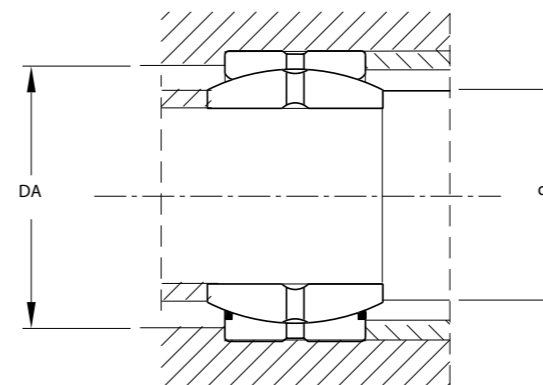
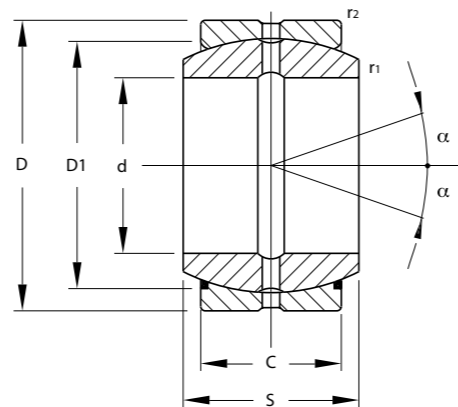

SIGLA CODE	SIGLA CUSCINETTO CON TENUTA CODE BEARING WITH PROTECTION RINGS	d		D		S		C		TOLLERANZA TOLERANCE			
		mm.		mm.		mm.		mm.		D	d	S	C
		POLLICI / INCHES	mm.	POLLICI / INCHES	mm.	POLLICI / INCHES	mm.	POLLICI / INCHES	mm.	mm.	mm.	mm.	mm.
SR 12 ZO		0.500	12.7	0.875	22.225	0.437	11.1	0.375	9.525	0 ± 0.009	0 ± 0.008	0 ± 0.12	0 ± 0.24
SR 15 ZO		0.625	15.87	1.062	26.988	0.547	13.894	0.469	11.91	0 ± 0.009	0 ± 0.008	0 ± 0.12	0 ± 0.24
SR 19 ZO	SR 19 ZO - 2RS	0.750	19.05	1.250	31.75	0.659	16.662	0.562	14.27	0 ± 0.009	0 ± 0.008	0 ± 0.12	0 ± 0.24
SR 22 ZO	SR 22 ZO - 2RS	0.875	22.22	1.437	36.513	0.765	19.431	0.656	16.66	0 ± 0.011	0 ± 0.010	0 ± 0.12	0 ± 0.24
SR 25 ZO	SR 25 ZO - 2RS	1.000	25.4	1.625	41.275	0.875	22.225	0.750	19.05	0 ± 0.011	0 ± 0.010	0 ± 0.12	0 ± 0.24
SR 31 ZO	SR 31 ZO - 2RS	1.250	31.75	2.000	50.8	1.093	27.762	0.937	23.8	0 ± 0.011	0 ± 0.010	0 ± 0.12	0 ± 0.30
SR 34 ZO	SR 34 ZO - 2RS	1.375	34.92	2.187	55.563	1.187	30.15	1.031	26.18	0 ± 0.013	0 ± 0.010	0 ± 0.12	0 ± 0.30
SR 38 ZO	SR 38 ZO - 2RS	1.500	38.1	2.437	61.913	1.321	33.325	1.125	28.57	0 ± 0.013	0 ± 0.012	0 ± 0.12	0 ± 0.30
SR 44 ZO	SR 44 ZO - 2RS	1.750	44.45	2.812	71.438	1.531	38.887	1.312	33.32	0 ± 0.013	0 ± 0.012	0 ± 0.12	0 ± 0.30
SR 47 ZO (1)	SR 47 ZO - 2RS(1)	1.875	47.63	3.562	90.488	1.969	50.013	1.687	42.85	0 ± 0.013	0 ± 0.012	0 ± 0.12	0 ± 0.40
SR 50 ZO	SR 50 ZO - 2RS	2.000	50.8	3.187	80.963	1.750	44.45	1.500	38.1	0 ± 0.013	0 ± 0.012	0 ± 0.12	0 ± 0.40
SR 57 ZO	SR 57 ZO - 2RS	2.250	57.15	3.562	90.488	1.969	50.013	1.687	42.85	0 ± 0.015	0 ± 0.012	0 ± 0.12	0 ± 0.40
SR 63 ZO	SR 63 ZO - 2RS	2.500	63.5	3.937	100.013	2.187	55.55	1.875	47.62	0 ± 0.015	0 ± 0.015	0 ± 0.15	0 ± 0.40
SR 69 ZO	SR 69 ZO - 2RS	2.750	69.85	4.375	111.125	2.406	61.112	2.062	52.37	0 ± 0.015	0 ± 0.015	0 ± 0.15	0 ± 0.40
SR 76 ZO	SR 76 ZO - 2RS	3.000	76.2	4.750	120.65	2.625	66.675	2.250	57.15	0 ± 0.015	0 ± 0.015	0 ± 0.15	0 ± 0.50
SR 82 ZO	SR 82 ZO - 2RS	3.250	82.55	5.125	130.175	2.844	72.238	2.437	61.9	0 ± 0.018	0 ± 0.020	0 ± 0.20	0 ± 0.50
SR 88 ZO	SR 88 ZO - 2RS	3.500	88.9	5.500	139.7	3.062	77.775	2.625	66.67	0 ± 0.018	0 ± 0.020	0 ± 0.20	0 ± 0.50

d	D1	ANGOLO DI OSCILLAZIONE α SWINGING ANGLE α	FATTORI DI CARICO LIMITE LOAD FACTORS		GIUOCO RADIALE RADIAL CLEARANCE	r1	r2	DIMENSIONI DI MONTAGGIO MOUNTING DIMENSIONS		PESO IN Kg. WEIGHT Kg.
			Dinamico Dynamic	Statico Static		min.	min.	da max.	DA min.	
			C	Co		KN	KN	mm.	mm.	
12.7	18	6	13.7	41.5	0.050 - 0.150	0.15	0.6	14.1	16	0.02
15.875	23	6	22	65.5	0.050 - 0.150	0.15	0.6	18.3	20.5	0.04
19.05	27.5	6	31.5	95	0.080 - 0.180	0.3	0.6	21.8	24.5	0.05
22.225	32	6	42.5	127	0.080 - 0.180	0.3	0.6	25.4	28.5	0.08
25.4	35.5	6	54	163	0.080 - 0.180	0.3	0.6	27.6	31.5	0.11
31.75	45.5	6	86.5	260	0.080 - 0.180	0.6	0.6	36	40.5	0.22
34.925	49	6	102	310	0.080 - 0.180	0.6	1.0	38.6	43.5	0.32
38.1	53	6	122	365	0.080 - 0.180	0.6	1.0	41.2	46.5	0.40
44.45	63.9	6	170	510	0.080 - 0.180	0.6	1.0	50.7	57	0.62
47.638	82	6	280	850	0.080 - 0.180	0.6	1.0	64.9	73	1.10
50.8	73	6	224	670	0.080 - 0.180	0.6	1.0	57.9	65	0.90
57.15	82	6	280	850	0.100 - 0.200	0.6	1.0	64.9	73	1.30
63.5	92	6	355	1060	0.100 - 0.200	1.0	1.0	73.3	82	1.80
69.85	100	6	375	1250	0.100 - 0.200	1.0	1.0	79.1	89	2.40
76.2	109.5	6	500	1500	0.100 - 0.200	1.0	1.0	86.8	98	3.00
82.55	119	6	600	1760	0.130 - 0.230	1.0	1.0	94.5	106	3.80
88.9	128	6	680	2040	0.130 - 0.230	1.0	1.0	101.6	114	4.80

**DIS.A**

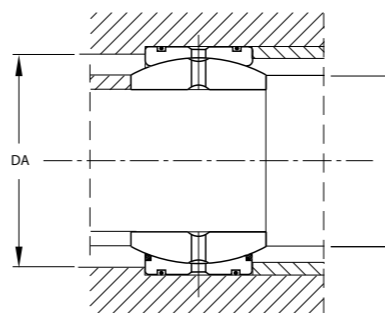
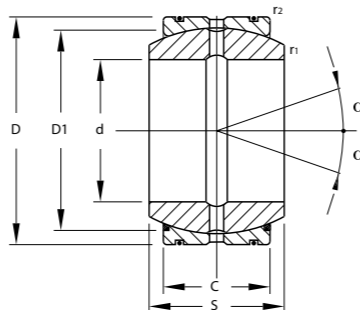

SIGLA CUSCINETTO CON TENUTA CODE BEARING WITH PROTECTION RINGS (*)	DIS.A	d		D		S		C		TOLLERANZA TOLERANCE			
		mm.		mm.		mm.		mm.		d	D	S	C
		POLLICI / INCHES	mm.	POLLICI / INCHES	mm.	POLLICI / INCHES	mm.	POLLICI / INCHES	mm.	mm.	mm.	mm.	mm.
SR 95 ZO	DIS.A	3.750	95.25	5.875	149.225	3.281	3.337	2.812	71.425	0 ± -0.020	0 ± -0.018	0 ± -0.20	0 ± -0.50
SR 101 ZO	DIS.A	4.000	101.60	6.250	158.75	3.500	88.900	3.000	76.20	0 ± -0.020	0 ± -0.018	0 ± -0.20	0 ± -0.50
SR 107 ZO	DIS.A	4.250	107.95	6.625	168.275	3.719	94.463	3.187	80.95	0 ± -0.020	0 ± -0.025	0 ± -0.20	0 ± -0.50
SR 114 ZO (1)	DIS.A	4.500	114.30	7.000	177.8	3.937	100.000	3.375	85.725	0 ± -0.020	0 ± -0.025	0 ± -0.20	0 ± -0.50
SR 120 ZO	DIS.A	4.750	120.65	7.375	187.325	4.156	105.562	3.562	90.475	0 ± -0.025	0 ± -0.025	0 ± -0.25	0 ± -0.60
SR 127 ZO (1)	DIS.A	5.000	127.00	7.750	196.85	4.375	111.125	3.750	95.25	0 ± -0.025	0 ± -0.030	0 ± -0.25	0 ± -0.60
SR 152 ZO	DIS.A	6.000	152.40	8.750	222.25	4.750	120.650	4.125	104.77	0 ± -0.025	0 ± -0.030	0 ± -0.25	0 ± -0.60

d	D1	ANGOLO DI OSCILLAZIONE α SWINGING ANGLE α	FATTORI DI CARICO LIMITE LOAD FACTORS		GIUOCO RADIALE RADIAL CLEARANCE	r1	r2	DIMENSIONI DI MONTAGGIO MOUNTING DIMENSIONS		PESO IN Kg. WEIGHT Kg.
			Dinamico Dynamic	Statico Static		min.	min.	da max.	DA min.	
			C	Co		KN	KN	mm.	mm.	
95.25	137	6	780	2360	0.130 - 0.230	1.0	1.0	108.7	122	5.80
101.6	146	6	900	2650	0.130 - 0.230	1.0	1.0	115.8	130	7.00
107.95	155	6	1000	3000	0.130 - 0.230	1.0	1.0	122.8	138	8.40
114.3	164.5	6	1120	3400	0.130 - 0.230	1.0	1.0	130.6	147	9.80
120.65	173.5	6	1250	3750	0.130 - 0.230	1.0	1.0	137.6	154	11.50
127.0	183	6	1400	4150	0.130 - 0.230	1.0	1.0	145.3	163	13.50
152.4	207	5	1730	5200	0.130 - 0.230	1.0	1.0	168.2	186	17.50

(\*) ANELLO ESTERNO IN DUE META' (TRATTENUTE MEDIANTE DUE ANELLI) - (1) DISPONIBILITA' E PREZZO A RICHIESTA.  
 NOTA: PER EVITARE IL DANNEGGIAMENTO O LA PERDITA DELLE PROTEZIONI (-2RS) E' NECESSARIO IMPEDIRE ALL'ANELLO INTERNO DI RUOTARE AL DI FUORI DELL'ANELLO ESTERNO.  
 TALE AVVERTENZA SI RIFERISCE IN PARTICOLARE MODO AGLI SNODI CON ANELLO ESTERNO DIVISO IN DUE META', TENUTE INSIEME MEDIANTE UN NASTRO DI ACCIAIO.

(\*) EXTERNAL RING DIVIDED IN 2 HALF  
 (1) AVAILABILITY AND PRICE UPON REQUEST

NOTES: TO AVOID THE DAMAGE OR THE LOSS OF THE PROTECTION RINGS (-2RS) DO NOT ALLOW INNER BALL TO ROTATE OUT OF THE EXTERNAL HOUSING.



**SR...SX**  
(GE...SX; GAC...S)

SNODI SFERICI A CONTATTO OBLIQUO  
RICHIEDENTI MANUTENZIONE  
ACCOPIAMENTO: ACCIAIO SU ACCIAIO

ANGULAR CONTACT SPHERICAL PLAIN BEARINGS  
REQUIRING MAINTENANCE  
COUPLING: STEEL/STEEL

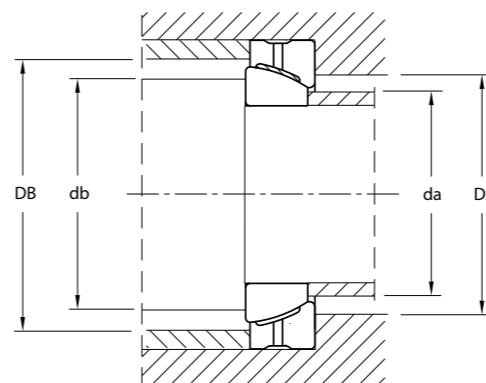
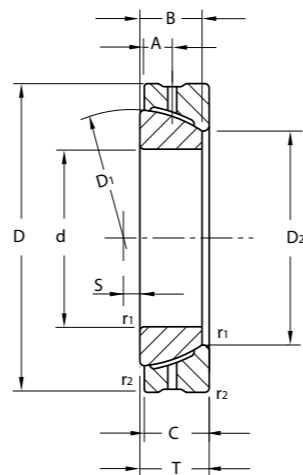

SIGLA CODE	d	D	T	B	C	TOLLERANZA TOLERANCE					D1	D2
						d	D	T	B	C		
	mm.											
SR 25 SX	25	47	15	15	14	0 ± -0.012	0 ± -0.014	±0.25	0 ± -0.20	0 ± -0.20	42.5	31.4
SR 28 SX	28	52	16	15	15	0 ± -0.012	0 ± -0.016	±0.25	0 ± -0.20	0 ± -0.20	47	35.7
SR 30 SX	30	55	17	17	15	0 ± -0.012	0 ± -0.016	±0.25	0 ± -0.20	0 ± -0.20	50	36.1
SR 32 SX	32	58	17	16	16	0 ± -0.012	0 ± -0.016	±0.25	0 ± -0.24	0 ± -0.24	53	39.3
SR 35 SX	35	62	18	18	16	0 ± -0.012	0 ± -0.016	±0.25	0 ± -0.24	0 ± -0.24	56	42.4
SR 40 SX	40	68	19	19	17	0 ± -0.012	0 ± -0.016	±0.25	0 ± -0.24	0 ± -0.24	60	46.8
SR 45 SX	45	75	20	20	18	0 ± -0.012	0 ± -0.016	±0.25	0 ± -0.24	0 ± -0.24	66	52.9
SR 50 SX	50	80	20	20	19	0 ± -0.012	0 ± -0.016	±0.25	0 ± -0.30	0 ± -0.30	74	59.1
SR 55 SX	55	90	23	23	20	0 ± -0.015	0 ± -0.018	±0.25	0 ± -0.30	0 ± -0.30	80	62
SR 60 SX	60	95	23	23	21	0 ± -0.015	0 ± -0.018	±0.25	0 ± -0.30	0 ± -0.30	86	68.1
SR 65 SX	65	100	23	23	22	0 ± -0.015	0 ± -0.018	±0.25	0 ± -0.30	0 ± -0.30	92	75.6
SR 70 SX	70	110	25	25	23	0 ± -0.015	0 ± -0.018	±0.25	0 ± -0.30	0 ± -0.30	102	82.2
SR 75 SX	75	115	25	25	24	0 ± -0.015	0 ± -0.018	±0.25	0 ± -0.30	0 ± -0.30	105	85.9
SR 80 SX	80	125	29	29	25.5	0 ± -0.015	0 ± -0.020	±0.25	0 ± -0.30	0 ± -0.30	115	90.5
SR 85 SX	85	130	29	29	26.5	0 ± -0.020	0 ± -0.020	±0.25	0 ± -0.40	0 ± -0.40	120	96.9
SR 90 SX	90	140	32	32	28	0 ± -0.020	0 ± -0.020	±0.25	0 ± -0.40	0 ± -0.40	130	103.3
SR 95 SX	95	145	32	32	29.5	0 ± -0.020	0 ± -0.020	±0.25	0 ± -0.40	0 ± -0.40	130	107.7
SR 100 SX	100	150	32	32	31	0 ± -0.020	0 ± -0.020	±0.25	0 ± -0.40	0 ± -0.40	140	114.3
SR 105 SX	105	160	35	35	32.5	0 ± -0.020	0 ± -0.025	±0.25	0 ± -0.40	0 ± -0.40	150	119.4
SR 110 SX	110	170	38	38	34	0 ± -0.020	0 ± -0.025	±0.25	0 ± -0.40	0 ± -0.40	160	125.8
SR 120 SX	120	180	38	38	37	0 ± -0.020	0 ± -0.025	±0.35	0 ± -0.40	0 ± -0.40	170	135.4
SR 130 SX	130	200	45	45	43	0 ± -0.025	0 ± -0.030	±0.35	0 ± -0.50	0 ± -0.50	190	148
SR 140 SX	140	210	45	45	43	0 ± -0.025	0 ± -0.030	±0.35	0 ± -0.50	0 ± -0.50	200	160.6
SR 150 SX	150	225	48	48	46	0 ± -0.025	0 ± -0.030	±0.35	0 ± -0.50	0 ± -0.50	213	170.9
SR 160 SX	160	240	51	51	49	0 ± -0.025	0 ± -0.030	±0.35	0 ± -0.50	0 ± -0.50	225	181.4
SR 170 SX	170	260	57	57	55	0 ± -0.025	0 ± -0.035	±0.35	0 ± -0.50	0 ± -0.50	250	194.3
SR 180 SX	180	280	64	64	61	0 ± -0.025	0 ± -0.035	±0.35	0 ± -0.50	0 ± -0.50	260	205.5
SR 190 SX	190	290	64	64	62	0 ± -0.030	0 ± -0.035	±0.35	0 ± -0.50	0 ± -0.50	275	211.8
SR 200 SX	200	310	70	70	66	0 ± -0.030	0 ± -0.035	±0.35	0 ± -0.60	0 ± -0.60	290	229.2

d	S	A	FATTORI DI CARICO RADIALE RADIAL LOAD FACTORS		r1	r2	DIMENSIONI DI MONTAGGIO MOUNTING DIMENSIONS				PESO IN Kg WEIGHT Kg
			Dinamico Dynamic C	Statico Static Co			DA min.	DB min.	da max.	db max.	
	mm.		KN		mm.				Kg.		
25	1	7.5	50	250	0.6	- 0.2	34	43	30.1	39.5	0.13
28	1	8	60	300	1.0	- 0.3	40	47.5	34.4	42	0.17
30	2	8.5	63	315	1.0	- 0.3	40.5	50.5	34.6	45	0.21
32	2.5	8.5	71	354	1.0	- 0.3	44	54	37.9	47.5	0.23
35	2	9	78	390	1.0	- 0.3	47	57	41.1	50	0.27
40	1.5	9.5	92	463	1.0	- 0.3	52	61	45.5	54	0.32
45	1.5	10	108	540	1.0	- 0.3	58	67	51.7	60	0.41
50	4	10	123	618	1.0	- 0.3	65	75	57.9	67	0.45
55	4	11.5	144	721	1.5	- 0.6	70	81	60.7	71	0.67
60	5	11.5	163	817	1.5	- 0.6	76	87	66.9	77	0.72
65	5	11.5	180	905	1.5	- 0.6	84	93	74.4	83	0.76
70	7	12.5	206	1030	1.5	- 0.6	90	104	80.9	92	1.00
75	7	12.5	220	1129	1.5	- 0.6	94	107	84.7	95	1.10
80	10	14.5	258	1290	1.5	- 0.6	99	117	88	104	1.50
85	10	14.5	284	1422	1.5	- 0.6	105	122	94.4	109	1.60
90	11	16	316	1580	2.0	- 0.6	112	132	100.8	118	2.10
95	8	16	350	1750	2.0	- 0.6	117	132	105.4	119	2.20
100	12	16	384	1923	2.0	- 0.6	123	142	112	128	2.30
105	14	17.5	423	2116	2.5	- 0.6	129	152	116.8	137	2.90
110	15	19	463	2318	2.5	- 0.6	135	162	123.2	146	3.60
120	17	19	547	2735	2.5	- 0.6	145	172	132.9	155	3.90
130	20	22.5	710	3550	2.5	- 0.6	158	192	143.9	174	5.90
140	20	22.5	740	3740	2.5	- 0.6	171	202	156.9	184	6.30
150	21	24	850	4270	3.0	- 1.0	184	216	167.1	194	7.70
160	21	25.5	970	4850	3.0	- 1.0	195	228	177.7	206	9.40
170	27	28.5	1190	5950	3.0	- 1.0	208	253	190.4	228	12.00
180	21	32	1395	6970	3.0	- 1.0	220	263	201.7	240	17.00
190	29	32	1500	7500	3.0	- 1.0	226	278	207.9	252	18.00
200	26	35	1680	8420	3.0	- 1.0	244	293	224.1	268	22.50

DISPONIBILITA' E PREZZO A RICHIESTA  
AVAILABILITY AND PRICE UPON REQUEST

richiedenti manutenzione/requiring maintenance

**SR...AX**  
(GE...AX; GX...S)

SNODI SFERICI ASSIALI  
RICHIEDENTI MANUTENZIONE  
ACCOPIAMENTO: ACCIAIO SU ACCIAIO

AXIAL SPHERICAL PLAIN BEARINGS  
REQUIRING MAINTENANCE  
COUPLING: STEEL/STEEL

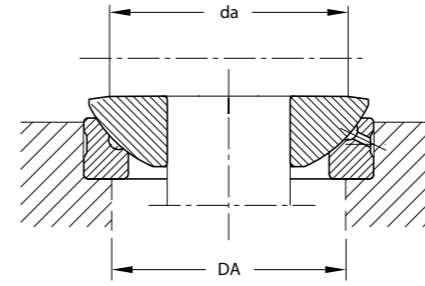
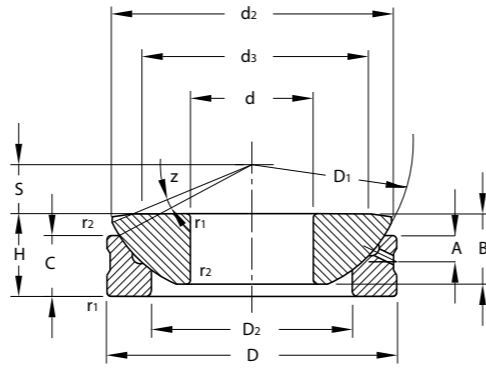

SIGLA CODE	d	D	H	B	C	TOLLERANZA TOLERANCE					D1	D2	d2	d3
						d	D	H	B	C				
mm.														
SR 10AX	10	30	9.5	7.5	7	0 ± -0.008	0 ± -0.009	0 ± -0.40	0 ± -0.24	0 ± -0.24	32	15.5	27.5	21
SR 12AX	12	35	13	9.5	9.3	0 ± -0.008	0 ± -0.011	0 ± -0.40	0 ± -0.24	0 ± -0.24	37	18	32	24
SR 15AX	15	42	15	11	10.8	0 ± -0.008	0 ± -0.011	0 ± -0.40	0 ± -0.24	0 ± -0.24	45	22.5	38.9	29
SR 17AX	17	47	16	11.8	11.2	0 ± -0.008	0 ± -0.011	0 ± -0.40	0 ± -0.24	0 ± -0.24	50	27	43.4	34
SR 20AX	20	55	20	14.5	13.8	0 ± -0.010	0 ± -0.013	0 ± -0.40	0 ± -0.24	0 ± -0.24	60	31	50	40
SR 25AX	25	62	22.5	16.5	16.7	0 ± -0.010	0 ± -0.013	0 ± -0.40	0 ± -0.24	0 ± -0.24	66	34.5	58.5	45
SR 30AX	30	75	26	19	19	0 ± -0.010	0 ± -0.013	0 ± -0.40	0 ± -0.24	0 ± -0.24	80	42	70	56
SR 35AX	35	90	28	22	20.7	0 ± -0.012	0 ± -0.015	0 ± -0.40	0 ± -0.30	0 ± -0.30	98	50.5	84	66
SR 40AX	40	105	32	27	21.5	0 ± -0.012	0 ± -0.015	0 ± -0.40	0 ± -0.30	0 ± -0.30	114	59	97	78
SR 45AX	45	120	36.5	31	25.5	0 ± -0.012	0 ± -0.015	0 ± -0.40	0 ± -0.30	0 ± -0.30	130	67	110	89
SR 50AX	50	130	42.5	33	30.5	0 ± -0.012	0 ± -0.018	0 ± -0.40	0 ± -0.30	0 ± -0.30	140	70	120	98
SR 60AX	60	150	45	37	34	0 ± -0.015	0 ± -0.018	0 ± -0.40	0 ± -0.30	0 ± -0.30	160	84	140	108
SR 70AX	70	160	50	42	36.5	0 ± -0.015	0 ± -0.025	0 ± -0.40	0 ± -0.30	0 ± -0.30	170	94.5	153	121
SR 80AX	80	180	50	43.5	38	0 ± -0.015	0 ± -0.025	0 ± -0.40	0 ± -0.30	0 ± -0.30	194	107.5	172	130
SR 100AX	100	210	59	51	46	0 ± -0.020	0 ± -0.030	0 ± -0.40	0 ± -0.40	0 ± -0.40	220	127	198	155
SR 120AX	120	230	64	53.5	50	0 ± -0.020	0 ± -0.030	0 ± -0.40	0 ± -0.40	0 ± -0.40	245	145	220	170
SR 140AX	140	260	72	61	54	0 ± -0.025	0 ± -0.035	0 ± -0.50	0 ± -0.50	0 ± -0.50	272	177	244	198
SR 160AX	160	290	77	66	58	0 ± -0.025	0 ± -0.035	0 ± -0.50	0 ± -0.50	0 ± -0.50	310	200	272	213
SR 180AX	180	320	86	74	62	0 ± -0.025	0 ± -0.040	0 ± -0.50	0 ± -0.50	0 ± -0.50	335	225	299	240
SR 200AX	200	340	87	80	66	0 ± -0.030	0 ± -0.040	0 ± -0.60	0 ± -0.60	0 ± -0.60	358	247	320	265

d	S	A	ANGOLO DI OSCILLAZIONE Z SWINGING ANGLE Z	FATTORI DI CARICO LIMITE LOAD FACTORS		r1	r2	DIMENSIONI DI MONTAGGIO MOUNTING DIMENSIONS		PESO IN Kg. WEIGHT Kg.
				Dinamico Dynamic C	Statico Static Co			da max.	DA min.	
mm.			Z°	KN		mm.		Kg.		
10	7	3	10	27	136	0.6	- 0.2	21	18.5	0.04
12	8	4	9	37	188	0.6	- 0.2	24	21.5	0.07
15	10	5	7	53	267	0.6	- 0.2	29	26	0.72
17	11	5	6	61	311	0.6	- 0.15	34	30.5	0.16
20	12.5	6	6	84	425	1.0	- 0.3	40	38	0.25
25	14	6	7	134	672	1.0	- 0.3	45	39	0.38
30	17.5	8	6	182	909	1.0	- 0.3	56	49	0.65
35	22	8	6	266	1330	1.0	- 0.3	66	57	1.00
40	24.5	9	6	357	1810	1.0	- 0.3	78	64	1.60
45	27.5	11	6	486	2470	1.0	- 0.3	89	74	2.40
50	30	10	5	554	2810	1.0	- 0.3	98	75	3.30
60	35	12.5	7	748	3820	1.0	- 0.3	108	92	4.50
70	35	13.5	6	902	4610	1.0	- 0.3	121	102	5.50
80	42.5	14.5	6	1110	5700	1.0	- 0.3	130	115	7.00
100	45	15	7	1300	6470	1.0	- 0.3	155	141	10.50
120	52.5	16.5	8	1530	7580	1.0	- 0.3	170	162	13.00
140	52.5	23	6	1820	9040	1.5	- 0.6	198	187	18.00
160	65	23	7	2100	10440	1.5	- 0.6	213	211	23.00
180	67.5	26	8	2430	12070	1.5	- 0.6	240	236	31.00
200	70	27	8	3070	15280	1.5	- 0.6	265	259	34.00

DISPONIBILITA' E PREZZO A RICHIESTA  
AVAILABILITY AND PRICE UPON REQUEST

non richiedenti manutenzione/maintenance free

**SRB...**

**SRT... - 2RS**

(GE...C; GE...UK; GE...UK-2RS; GE...TXE-2LS; GE...TXA-2LS; GE...ET-2RS)

SNODI SFERICI RADIALI

ISO 12240-1 SERIE E

NON RICHIEDENTI MANUTENZIONE

ACCOPIAMENTO CROMO DURO SU PTFE (SRT)

ACCOPIAMENTO ACCIAIO SU BRONZO SINTERIZZATO-PTFE (SRB)

SPHERICAL PLAIN BEARINGS

ISO 12240-1 SERIES E

MAINTENANCE FREE

COUPLING HARD CHROMIUM ON PTFE (SRT)

COUPLING STEEL ON SINTER BRONZE-PTFE (SRB)

**ALTA RESISTENZA  
HIGH RESISTANCE**

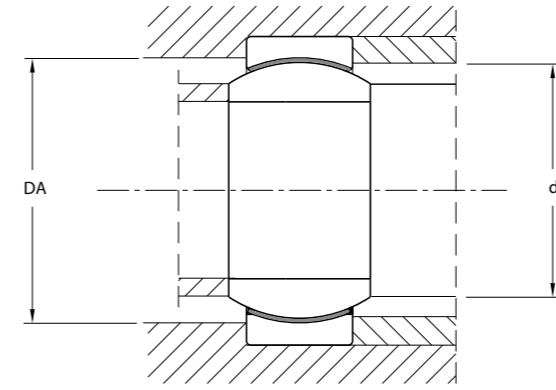
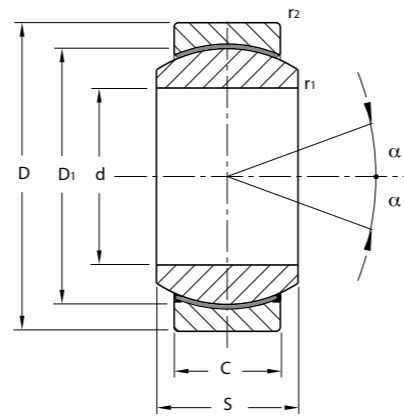

SIGLA CUSCINETTO SENZA TENUTA CODE BEARING WITHOUT PROTECTION RINGS	SIGLA CUSCINETTO CON TENUTA CODE BEARING WITH PROTECTION RINGS	d	D	S	C	TOLLERANZA TOLERANCE				r1	r2
						d	D	S	C		
mm.											
SRB 6		6	14	6	4	0+-0.008	0+-0.008	0+-0.12	0+-0.24	0.3	0.3
SRB 8		8	16	8	5	0+-0.008	0+-0.008	0+-0.12	0+-0.24	0.3	0.3
SRB 10		10	19	9	6	0+-0.008	0+-0.009	0+-0.12	0+-0.24	0.3	0.3
SRB 12		12	22	10	7	0+-0.008	0+-0.009	0+-0.12	0+-0.24	0.3	0.3
SRB 15		15	26	12	9	0+-0.008	0+-0.009	0+-0.12	0+-0.24	0.3	0.3
SRB 17	SRT 17 - 2RS	17	30	14	10	0+-0.008	0+-0.009	0+-0.12	0+-0.24	0.3	0.3
SRB 20	SRT 20 - 2RS	20	35	16	12	0+-0.010	0+-0.011	0+-0.12	0+-0.24	0.3	0.3
SRB 25	SRT 25 - 2RS	25	42	20	16	0+-0.010	0+-0.011	0+-0.12	0+-0.24	0.6	0.3
SRB 30	SRT 30 - 2RS	30	47	22	18	0+-0.010	0+-0.011	0+-0.12	0+-0.24	0.6	0.6
	SRT 35 - 2RS	35	55	25	20	0+-0.012	0+-0.013	0+-0.12	0+-0.30	0.6	0.6
	SRT 40 - 2RS	40	62	28	22	0+-0.012	0+-0.013	0+-0.12	0+-0.30	0.6	1.0
	SRT 45 - 2RS	45	68	32	25	0+-0.012	0+-0.013	0+-0.12	0+-0.30	0.6	1.0
	SRT 50 - 2RS	50	75	35	28	0+-0.012	0+-0.013	0+-0.12	0+-0.30	0.6	1.0
	SRT 60 - 2RS	60	90	44	36	0+-0.015	0+-0.015	0+-0.15	0+-0.40	0.6	1.0
	SRT 70 - 2RS	70	105	49	40	0+-0.015	0+-0.015	0+-0.15	0+-0.40	1.0	1.0
	SRT 80 - 2RS	80	120	55	45	0+-0.015	0+-0.015	0+-0.15	0+-0.40	1.0	1.0
	SRT 90 - 2RS	90	130	60	50	0+-0.020	0+-0.018	0+-0.20	0+-0.50	1.0	1.0
	SRT 100 - 2RS	100	150	70	55	0+-0.020	0+-0.018	0+-0.20	0+-0.50	1.0	1.0
	SRT 110 - 2RS	110	160	70	55	0+-0.020	0+-0.025	0+-0.20	0+-0.50	1.0	1.0
	SRT 120 - 2RS	120	180	85	70	0+-0.020	0+-0.025	0+-0.20	0+-0.50	1.0	1.0
	SRT 140 - 2RS	140	210	90	70	0+-0.025	0+-0.030	0+-0.25	0+-0.60	1.0	1.0
	SRT 160 - 2RS (1)	160	230	105	80	0+-0.025	0+-0.030	0+-0.25	0+-0.60	1.0	1.0
	SRT 180 - 2RS (1)	180	260	105	80	0+-0.025	0+-0.035	0+-0.25	0+-0.70	1.0	1.0
	SRT 200 - 2RS (1)	200	290	130	100	0+-0.030	0+-0.035	0+-0.30	0+-0.70	1.1	1.1
	SRT 220 - 2RS (1)	220	320	135	100	0+-0.030	0+-0.040	0+-0.30	0+-0.80	1.1	1.1
	SRT 240 - 2RS (1)	240	340	140	100	0+-0.030	0+-0.040	0+-0.30	0+-0.80	1.1	1.1
	SRT 260 - 2RS (1)	260	370	150	110	0+-0.035	0+-0.040	0+-0.35	0+-0.80	1.1	1.1
	SRT 280 - 2RS (1)	280	400	155	120	0+-0.035	0+-0.040	0+-0.35	0+-0.80	1.1	1.1
	SRT 300 - 2RS (1)	300	430	165	120	0+-0.035	0+-0.045	0+-0.35	0+-0.90	1.1	1.1

(1)DISPONIBILITA'E PREZZO A RICHIESTA

**NOTA:** PER EVITARE IL DANNEGGIAMENTO O LA PERDITA DELLE PROTEZIONI (-2RS) E' NECESSARIO IMPEDIRE ALL'ANELLO INTERNO DI RUOTARE AL DI FUORI DELL'ANELLO ESTERNO. TALE AVVERTENZA SI RIFERISCE IN PARTICOLARE MODO AGLI SNODI CON ANELLO ESTERNO DIVISO IN DUE META', TENUTE INSIEME MEDIANTE UN NASTRO DI ACCIAIO.

(1) AVAILABILITY AND PRICE UPON REQUEST

**NOTES:** TO AVOID THE DAMAGE OR THE LOSS OF THE PROTECTION RINGS(-2RS) DO NOT ALLOW INNER BALL TO ROTATE OUT OF THE EXTERNAL HOUSING.

d	D1	ANGOLO DI OSCILLAZIONE α SWINGING ANGLE α	FATTORI DI CARICO LIMITE LOAD FACTORS		GIUOCO RADIALE RADIAL CLEARANCE	DIMENSIONI DI MONTAGGIO MOUNTING DIMENSIONS		PESO IN Kg. WEIGHT Kg.
			Dinamico Dynamic C	Statico Static Co		da max.	DA min.	
mm.	mm.	α°	KN	KN	mm.	mm.	Kg.	
6	10	13	3,6	9	0 - 0.032	8	9.6	0.004
8	13	15	5,85	14,6	0 - 0.032	10.2	12.5	0.007
10	16	12	8,65	21,6	0 - 0.032	13.2	15.5	0.01
12	18	11	11,4	28,5	0 - 0.032	14.9	17.5	0.01
15	22	8	17,6	44	0 - 0.040	18.4	21	0.02
17	25	10	22.4 - 48 (1)	56 - 81 (1)	0 - 0.040	20.7	24	0.03
20	29	9	31.5 - 68 (1)	78 - 112 (1)	0 - 0.040	24.1	27.5	0.06
25	35.5	7	51 - 130 (1)	127 - 225 (1)	0 - 0.050	29.3	33	0.11
30	40.7	6	65.5 - 170 (1)	166 - 285 (1)	0 - 0.050	34.2	38	0.14
35	47	6	220 (1)	370 (1)	0 - 0.050	39.7	44.5	0.22
40	53	7	280 (1)	465 (1)	0 - 0.060	45	51	0.30
45	60	7	360 (1)	600 (1)	0 - 0.060	50.7	57	0.40
50	66	6	440 (1)	735 (1)	0 - 0.060	55.9	63	0.54
60	80	6	690 (1)	1155 (1)	0 - 0.060	66.8	75	1.00
70	92	6	880 (1)	1470 (1)	0 - 0.072	77.8	87	1.50
80	105	6	1135 (1)	1900 (1)	0 - 0.072	89.4	99	2.20
90	115	5	1375 (1)	2320 (1)	0 - 0.072	98.1	108	2.70
100	130	7	1725 (1)	2860 (1)	0 - 0.085	109.5	123	4.30
110	140	6	1860 (1)	3100 (1)	0 - 0.085	121.2	134	4.70
120	160	6	2700 (1)	4500 (1)	0 - 0.085	135.5	150	8.00
140	180	7	3010 (1)	5020 (1)	0 - 0.085	155.8	173	11.00
160	200	8	3840 (1)	6400 (1)	0 - 0.100	170.2	191	13.50
180	225	6	4320 (1)	7200 (1)	0 - 0.100	198.9	219	18.50
200	250	7	6000 (1)	10000 (1)	0 - 0.100	213.5	239	28.00
220	275	8	6600 (1)	11000 (1)	0 - 0.100	239.5	267	35.50
240	300	8	7200 (1)	12000 (1)	0 - 0.100	265.3	295	40.00
260	325	7	8650 (1)	14300 (1)	0 - 0.110	288.3	319	50.00
280	350	6	10050 (1)	16750 (1)	0 - 0.110	313.8	342	64.00
300	375	7	10800 (1)	18000 (1)	0 - 0.110	336.7	370	75.00

(1)FATTORE DI CARICO PER ESECUZIONE DI CUSCINETTO SRT...- 2RS

(1) LOAD FACTORS BEARING SRT...-2RS

non richiedenti manutenzione/maintenance free

**SRLB...**

**SRLT... - 2RS**

(GEH...TXE-2LS; GEH...TXA-2LS; GE...FW-2RS; GEG...ET; GEG...XT-2RS)

SNODI SFERICI RADIALI

ISO 12240-1 SERIE G

NON RICHIEDENTI MANUTENZIONE

ACCOPIAMENTO CROMO DURO SU PTFE (SRLT)

ACCOPIAMENTO ACCIAIO SU BRONZO SINTERIZZATO-PTFE (SRLB)

SPHERICAL PLAIN BEARINGS

ISO 12240-1 SERIES G

MAINTENANCE FREE

COUPLING HARD CHROMIUM ON PTFE (SRLT)

COUPLING STEEL ON SINTER BRONZE-PTFE (SRLB)

**ALTA RESISTENZA  
HIGH RESISTANCE**

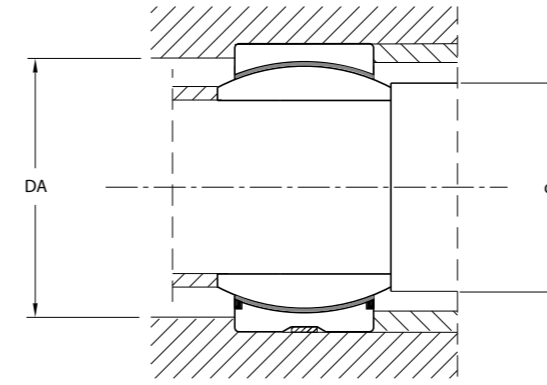
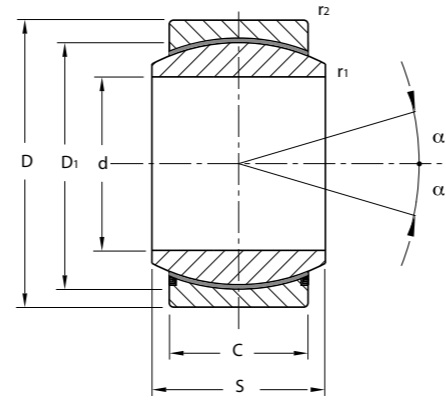

SIGLA CUSCINETTO SENZA TENUTA CODE BEARING WITHOUT PROTECTION RINGS	SIGLA CUSCINETTO CON TENUTA CODE BEARING WITH PROTECTION RINGS	d	D	s	c	TOLLERANZA TOLERANCE				r1	r2
						d	D	s	c		
mm.											
SRLB 6		6	16	9	5	0+-0.008	0+-0.008	0+-0.12	0+-0.24	0.3	0.3
SRLB 8		8	19	11	6	0+-0.008	0+-0.009	0+-0.12	0+-0.24	0.3	0.3
SRLB 10		10	22	12	7	0+-0.008	0+-0.009	0+-0.12	0+-0.24	0.3	0.3
SRLB 12		12	26	15	9	0+-0.008	0+-0.009	0+-0.12	0+-0.24	0.3	0.3
SRLB 15		15	30	16	10	0+-0.008	0+-0.009	0+-0.12	0+-0.24	0.3	0.3
SRLB 17		17	35	20	12	0+-0.008	0+-0.011	0+-0.12	0+-0.24	0.3	0.3
SRLB 20		20	42	25	16	0+-0.010	0+-0.011	0+-0.12	0+-0.24	0.6	0.6
SRLB 25		25	47	28	18	0+-0.010	0+-0.011	0+-0.12	0+-0.24	0.6	0.6
SRLB 30	SRLT 30 - 2RS	30	55	32	20	0+-0.010	0+-0.013	0+-0.12	0+-0.30	0.6	1.0
	SRLT 35 - 2RS	35	62	35	22	0+-0.012	0+-0.013	0+-0.12	0+-0.30	0.6	1.0
	SRLT 40 - 2RS	40	68	40	25	0+-0.012	0+-0.013	0+-0.12	0+-0.30	0.6	1.0
	SRLT 45 - 2RS	45	75	43	28	0+-0.012	0+-0.013	0+-0.12	0+-0.30	0.6	1.0
	SRLT 50 - 2RS	50	90	56	36	0+-0.012	0+-0.015	0+-0.15	0+-0.40	0.6	1.0
	SRLT 60 - 2RS	60	105	63	40	0+-0.015	0+-0.015	0+-0.15	0+-0.40	1.0	1.0
	SRLT 70 - 2RS	70	120	70	45	0+-0.015	0+-0.015	0+-0.15	0+-0.40	1.0	1.0
	SRLT 80 - 2RS	80	130	75	50	0+-0.015	0+-0.018	0+-0.20	0+-0.50	1.0	1.0
	SRLT 90 - 2RS	90	150	85	55	0+-0.020	0+-0.018	0+-0.20	0+-0.50	1.0	1.0
	SRLT 100 - 2RS	100	160	85	55	0+-0.020	0+-0.025	0+-0.20	0+-0.50	1.0	1.0
	SRLT 110 - 2RS	110	180	100	70	0+-0.020	0+-0.025	0+-0.20	0+-0.50	1.0	1.0
	SRLT 120 - 2RS	120	210	115	70	0+-0.020	0+-0.030	0+-0.25	0+-0.60	1.0	1.0
	SRLT 140 - 2RS	140	230	130	80	0+-0.025	0+-0.030	0+-0.25	0+-0.60	1.0	1.0
	SRLT 160 - 2RS	160	260	135	80	0+-0.025	0+-0.035	0+-0.25	0+-0.70	1.0	1.1
	SRLT 180 - 2RS	180	290	155	100	0+-0.025	0+-0.035	0+-0.30	0+-0.70	1.1	1.1
	SRLT 200 - 2RS (1)	200	320	165	100	0+-0.030	0+-0.040	0+-0.30	0+-0.80	1.1	1.1
	SRLT 220 - 2RS (1)	220	340	175	100	0+-0.030	0+-0.040	0+-0.30	0+-0.80	1.1	1.1
	SRLT 240 - 2RS (1)	240	370	190	110	0+-0.030	0+-0.040	0+-0.35	0+-0.80	1.1	1.1
	SRLT 260 - 2RS (1)	260	400	205	120	0+-0.035	0+-0.040	0+-0.35	0+-0.80	1.1	1.1
	SRLT 280 - 2RS (1)	280	430	210	120	0+-0.035	0+-0.045	0+-0.35	0+-0.90	1.1	1.1

d	D1	ANGOLO DI OSCILLAZIONE α SWINGING ANGLE α	FATTORI DI CARICO LIMITE LOAD FACTORS		GIUOCO RADIALE RADIAL CLEARANCE	DIMENSIONI DI MONTAGGIO MOUNTING DIMENSIONS		PESO IN Kg. WEIGHT Kg.
			Dinamico Dynamic C	Statico Static Co		da max.	DA min.	
mm.		α°	KN		mm.		Kg.	
6	13	21	5.85	14.6	0 - 0.032	9.3	12.5	0.008
8	16	21	8.65	21.6	0 - 0.032	11.6	15.5	0.01
10	18	18	11.4	28.5	0 - 0.032	13.4	17.5	0.02
12	22	18	17.6	44	0 - 0.040	16.0	21	0.03
15	25	16	22.4	56	0 - 0.040	19.2	24	0.04
17	29	19	31.5	78	0 - 0.040	21.0	27.5	0.07
20	35.5	17	51	127	0 - 0.050	25.2	33	0.15
25	40.7	17	65.5	166	0 - 0.050	29.5	38	0.19
30	47	17	210	350	0 - 0.050	34.4	44.5	0.29
35	53	16	275	465	0 - 0.060	39.7	51	0.39
40	60	17	360	600	0 - 0.060	44.7	57	0.52
45	66	15	440	740	0 - 0.060	50.0	63	0.68
50	80	17	690	1150	0 - 0.060	57.1	75	1.40
60	92	17	885	1475	0 - 0.072	67.0	87	2.00
70	105	16	1125	1875	0 - 0.072	78.2	99	2.90
80	115	14	1380	2300	0 - 0.072	87.1	108	3.50
90	130	15	1720	2860	0 - 0.085	98.3	123	5.40
100	140	14	1840	3070	0 - 0.085	111.2	134	5.90
110	160	12	2685	4480	0 - 0.085	124.8	150	9.70
120	180	16	3015	5030	0 - 0.085	138.4	173	15.00
140	200	16	3845	6400	0 - 0.100	151.9	191	18.50
160	225	16	4320	7210	0 - 0.100	180.0	219	25.00
180	250	14	6000	10000	0 - 0.100	196.1	239	35.50
200	275	15	6600	11000	0 - 0.100	220.0	267	45.00
220	300	16	7200	12000	0 - 0.100	243.6	295	51.00
240	325	15	8550	14250	0 - 0.100	263.6	319	64.00
260	350	15	10050	16750	0 - 0.110	283.6	342	81.00
280	375	15	10800	18000	0 - 0.110	310.6	370	94.00

(1)DISPONIBILITA'E PREZZO A RICHIESTA

**NOTA:** PER EVITARE IL DANNEGGIAMENTO O LA PERDITA DELLE PROTEZIONI (-2RS) E' NECESSARIO IMPEDIRE ALL'ANELLO INTERNO DI RUOTARE AL DI FUORI DELL'ANELLO ESTERNO. TALE AVVERTENZA SI RIFERISCE IN PARTICOLARE MODO AGLI SNODI CON ANELLO ESTERNO DIVISO IN DUE META', TENUTE INSIEME MEDIANTE UN NASTRO DI ACCIAIO.

(1) AVAILABILITY AND PRICE UPON REQUEST

**NOTES:** TO AVOID THE DAMAGE OR THE LOSS OF THE PROTECTION RINGS(-2RS) DO NOT ALLOW INNER BALL TO ROTATE OUT OF THE EXTERNAL HOUSING.

non richiedenti manutenzione/maintenance free

**SR...TGR** ACCIAIO INOX / STAINLESS STEEL  
**SR...TG3A-2RS** ACCIAIO INOX / STAINLESS STEEL  
**(GE...TXGR; GE...TXG3E-2LS; GE...TXG3A-2LS; GE...ET-X; GE...XT-2RSX)**

SNODI SFERICI RADIALI  
 ISO 12240-1 SERIE G  
 SERIE IN ACCIAIO INOSSIDABILE, NON RICHIEDENTI MANUTENZIONE  
 ACCOPPIAMENTO: ACCIAIO SU PTFE

SPHERICAL PLAIN BEARINGS  
 ISO 12240-1 SERIES G  
 SERIES IN STAINLESS STEEL, MAINTENANCE FREE  
 COUPLING: STEEL ON PTFE

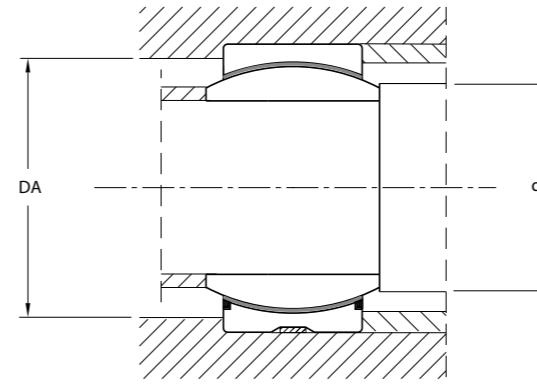
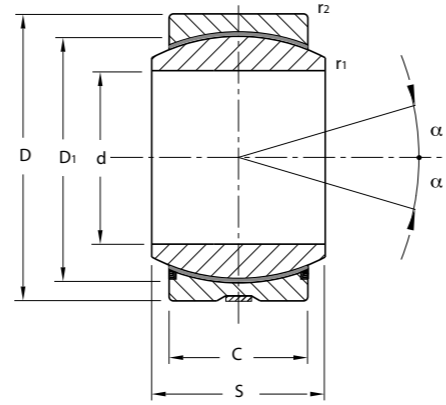

SIGLA CODE	d	D	S	C	TOLLERANZA TOLERANCE				r1	r2
					d	D	S	C		
mm.										
SR 12TGR	12	22	10	7	0 +- 0.008	0 +- 0.009	0 +- 0.12	0 +- 0.24	0.3	0.3
SR 15TGR	15	26	12	9	0 +- 0.008	0 +- 0.009	0 +- 0.12	0 +- 0.24	0.3	0.3
SR 17TGR	17	30	14	10	0 +- 0.008	0 +- 0.009	0 +- 0.12	0 +- 0.24	0.3	0.3
SR 20TGR	20	35	16	12	0 +- 0.010	0 +- 0.011	0 +- 0.12	0 +- 0.24	0.6	0.6
SR 25TGR (2RS)	25	42	20	16	0 +- 0.010	0 +- 0.011	0 +- 0.12	0 +- 0.24	0.6	0.6
SR 30TGR (2RS)	30	47	22	18	0 +- 0.010	0 +- 0.011	0 +- 0.12	0 +- 0.24	0.6	0.6
SR 35TGR (2RS)	35	55	25	20	0 +- 0.012	0 +- 0.013	0 +- 0.12	0 +- 0.30	0.6	1.0
SR 40TGR (2RS)	40	62	28	22	0 +- 0.012	0 +- 0.013	0 +- 0.12	0 +- 0.30	0.6	1.0
SR 45TGR (2RS)	45	68	32	25	0 +- 0.012	0 +- 0.013	0 +- 0.12	0 +- 0.30	0.6	1.0
SR 50TGR (2RS)	50	75	35	28	0 +- 0.012	0 +- 0.013	0 +- 0.12	0 +- 0.30	0.6	1.0
SR 60TGR (2RS)	60	90	44	36	0 +- 0.015	0 +- 0.015	0 +- 0.15	0 +- 0.40	1.0	1.0
SR 70TG3A (2RS)	70	105	49	40	0 +- 0.015	0 +- 0.015	0 +- 0.15	0 +- 0.40	1.0	1.0
SR 80TG3A (2RS)	80	120	55	45	0 +- 0.015	0 +- 0.015	0 +- 0.15	0 +- 0.40	1.0	1.0
SR 90TG3A (2RS)	90	130	60	50	0 +- 0.020	0 +- 0.018	0 +- 0.20	0 +- 0.50	1.0	1.0
SR 100TG3A-2RS	100	150	70	55	0 +- 0.020	0 +- 0.018	0 +- 0.20	0 +- 0.50	1.0	1.0
SR 110TG3A-2RS	110	160	70	55	0 +- 0.020	0 +- 0.025	0 +- 0.20	0 +- 0.50	1.0	1.0
SR 120TG3A-2RS	120	180	85	70	0 +- 0.020	0 +- 0.025	0 +- 0.20	0 +- 0.50	1.0	1.0
SR 140TG3A-2RS	140	210	90	70	0 +- 0.025	0 +- 0.030	0 +- 0.25	0 +- 0.60	1.0	1.0
SR 160TG3A-2RS	160	230	105	80	0 +- 0.025	0 +- 0.030	0 +- 0.25	0 +- 0.60	1.0	1.0
SR 180TG3A-2RS	180	260	105	80	0 +- 0.025	0 +- 0.035	0 +- 0.25	0 +- 0.70	1.1	1.1
SR 200TG3A-2RS	200	290	130	100	0 +- 0.030	0 +- 0.035	0 +- 0.30	0 +- 0.70	1.1	1.1
SR 220TG3A-2RS	220	320	135	100	0 +- 0.030	0 +- 0.040	0 +- 0.30	0 +- 0.80	1.1	1.1
SR 240TG3A-2RS	240	340	140	100	0 +- 0.030	0 +- 0.040	0 +- 0.30	0 +- 0.80	1.1	1.1
SR 260TG3A-2RS	260	370	150	110	0 +- 0.035	0 +- 0.040	0 +- 0.35	0 +- 0.80	1.1	1.1
SR 280TG3A-2RS	280	400	155	120	0 +- 0.035	0 +- 0.040	0 +- 0.35	0 +- 0.80	1.1	1.1
SR 300TG3A-2RS	300	430	165	120	0 +- 0.035	0 +- 0.045	0 +- 0.35	0 +- 0.90	1.1	1.1

d	D1	ANGOLO DI OSCILLAZIONE $\alpha$ SWINGING ANGLE $\alpha$	FATTORI DI CARICO LIMITE LOAD FACTORS		GIUOCO RADIALE RADIAL CLEARANCE	DIMENSIONI DI MONTAGGIO MOUNTING DIMENSIONS		PESO IN Kg. WEIGHT Kg.
			Dinamico Dynamic C	Statico Static Co		da max.	DA min.	
mm.	mm.	$\alpha^\circ$	KN	KN	mm.	mm.	Kg.	
12	18	10	15	30	0 - 0.032	14.9 17.5	0.017	
15	22	8	23.6	47.5	0 - 0.040	18.4 21	0.03	
17	25	10	30	60	0 - 0.040	20.7 24	0.04	
20	29	9	41.5	83	0 - 0.040	24.1 27.5	0.06	
25	35.5	7	68	137	0 - 0.050	29.3 33	0.12	
30	40.7	6	88	176	0 - 0.050	34.2 38	0.16	
35	47	6	112	224	0 - 0.050	39.7 44.5	0.23	
40	53	7	140	280	0 - 0.060	45 51	0.32	
45	60	7	180	360	0 - 0.060	50.7 57	0.46	
50	66	6	220	440	0 - 0.060	55.9 63	0.56	
60	80	6	345	695	0 - 0.060	66.8 75	1.10	
70	92	6	440	880	0 - 0.072	77.8 87	1.55	
80	105	6	570	1140	0 - 0.072	89.4 99	2.30	
90	115	5	695	1370	0 - 0.072	98.1 108	2.75	
100	130	7	865	1730	0 - 0.085	109.5 123	4.40	
110	140	6	930	1860	0 - 0.085	121.2 134	4.80	
120	160	6	1340	2700	0 - 0.085	135.5 150	8.25	
140	180	7	1500	3000	0 - 0.085	155.8 173	11.00	
160	200	8	1930	3800	0 - 0.100	170.2 191	14.00	
180	225	6	2160	4300	0 - 0.100	198.9 219	18.50	
200	250	7	3000	6000	0 - 0.100	213.5 239	28.00	
220	275	8	3350	6550	0 - 0.100	239.5 267	35.50	
240	300	8	3600	7200	0 - 0.100	265.3 295	40.00	
260	325	7	4300	8650	0 - 0.110	288.3 319	51.50	
280	350	6	5000	10000	0 - 0.110	313.8 342	65.00	
300	375	7	5400	10800	0 - 0.110	336.7 370	78.50	

DISPONIBILITA'E PREZZO A RICHIESTA.  
 GLI SNODI TIPO TGR... PRESENTANO L'ANELLO ESTERNO SENZA SPACCATURA  
**NOTA:** PER EVITARE IL DANNEGGIAMENTO O LA PERDITA DELLE PROTEZIONI (-2RS) E' NECESSARIO IMPEDIRE ALL'ANELLO INTERNO DI RUOTARE AL DI FUORI DELL'ANELLO ESTERNO.  
 TALE AVVERTENZA SI RIFERISCE IN PARTICOLARE MODO AGLI SNODI CON ANELLO ESTERNO DIVISO IN DUE META', TENUTE INSIEME MEDIANTE UN NASTRO DI ACCIAIO.

AVAILABILITY AND PRICE UPON REQUEST.  
**NOTES:** TO AVOID THE DAMAGE OR THE LOSS OF THE PROTECTION RINGS(-2RS) DO NOT ALLOW INNER BALL TO ROTATE OUT OF THE EXTERNAL HOUSING.  
 IN THE SPHERICAL PLAIN BEARING TGR... TYPE, THE OUTER RING IS WITHOUT CRACK

non richiedenti manutenzione/maintenance free

**SR...SW**  
(GAC...F; GE...SW; GAC...T)

SNODI SFERICI A CONTATTO OBLIQUO

NON RICHIEDENTI MANUTENZIONE  
ACCOPPIAMENTO : CROMO DURO SU PTFE

ANGULAR CONTACT SPHERICAL PLAIN BEARINGS

MAINTENANCE FREE  
COUPLING:HARD CHROMIUM /PTFE

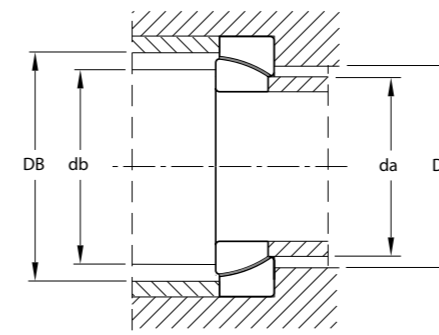
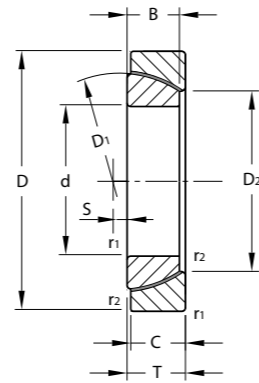

SIGLA CODE	d	D	T	B	C	TOLLERANZA TOLERANCE					D1	D2
						d	D	T	B	C		
	mm.											
SR 25 SW	25	47	15	15	14	0 ± -0.012	0 ± -0.014	±0.20	0 ± -0.20	0 ± -0.20	42.5	31.4
SR 28 SW	28	52	16	15	15	0 ± -0.012	0 ± -0.016	±0.20	0 ± -0.20	0 ± -0.20	47	35.7
SR 30 SW	30	55	17	17	15	0 ± -0.012	0 ± -0.016	±0.20	0 ± -0.20	0 ± -0.20	50	36.1
SR 32 SW	32	58	17	16	16	0 ± -0.012	0 ± -0.016	±0.20	0 ± -0.24	0 ± -0.24	53	39.3
SR 35 SW	35	62	18	18	16	0 ± -0.012	0 ± -0.016	±0.20	0 ± -0.24	0 ± -0.24	56	42.4
SR 40 SW	40	68	19	19	17	0 ± -0.012	0 ± -0.016	±0.20	0 ± -0.24	0 ± -0.24	60	46.8
SR 45 SW	45	75	20	20	18	0 ± -0.012	0 ± -0.016	±0.20	0 ± -0.24	0 ± -0.24	66	52.9
SR 50 SW	50	80	20	20	19	0 ± -0.012	0 ± -0.016	±0.20	0 ± -0.30	0 ± -0.30	74	59.1
SR 55 SW	55	90	23	23	20	0 ± -0.015	0 ± -0.018	±0.20	0 ± -0.30	0 ± -0.30	80	62
SR 60 SW	60	95	23	23	21	0 ± -0.015	0 ± -0.018	±0.20	0 ± -0.30	0 ± -0.30	86	68.1
SR 65 SW	65	100	23	23	22	0 ± -0.015	0 ± -0.018	±0.20	0 ± -0.30	0 ± -0.30	92	75.6
SR 70 SW	70	110	25	25	23	0 ± -0.015	0 ± -0.018	±0.20	0 ± -0.30	0 ± -0.30	102	82.2
SR 75 SW	75	115	25	25	24	0 ± -0.015	0 ± -0.018	±0.20	0 ± -0.30	0 ± -0.30	105	85.9
SR 80 SW	80	125	29	29	25.5	0 ± -0.015	0 ± -0.020	±0.20	0 ± -0.30	0 ± -0.30	115	90.5
SR 85 SW	85	130	29	29	26.5	0 ± -0.020	0 ± -0.020	±0.20	0 ± -0.40	0 ± -0.40	120	96.9
SR 90 SW	90	140	32	32	28	0 ± -0.020	0 ± -0.020	±0.20	0 ± -0.40	0 ± -0.40	130	103.3
SR 95 SW	95	145	32	32	29.5	0 ± -0.020	0 ± -0.020	±0.20	0 ± -0.40	0 ± -0.40	130	107.7
SR 100 SW	100	150	32	32	31	0 ± -0.020	0 ± -0.020	±0.20	0 ± -0.40	0 ± -0.40	140	114.3
SR 105 SW	105	160	35	35	32.5	0 ± -0.020	0 ± -0.025	±0.20	0 ± -0.40	0 ± -0.40	150	119.4
SR 110 SW	110	170	38	38	34	0 ± -0.020	0 ± -0.025	±0.20	0 ± -0.40	0 ± -0.40	160	125.8
SR 120 SW	120	180	38	38	37	0 ± -0.020	0 ± -0.025	±0.20	0 ± -0.40	0 ± -0.40	170	135.4
SR 130 SW	130	200	45	45	43	0 ± -0.025	0 ± -0.030	+0.35 -0.025	0 ± -0.50	0 ± -0.50	190	148
SR 140 SW	140	210	45	45	43	0 ± -0.025	0 ± -0.030	+0.35 -0.025	0 ± -0.50	0 ± -0.50	200	160.6
SR 150 SW	150	225	48	48	46	0 ± -0.025	0 ± -0.030	+0.35 -0.025	0 ± -0.50	0 ± -0.50	213	170.9
SR 160 SW	160	240	51	51	49	0 ± -0.025	0 ± -0.030	+0.35 -0.025	0 ± -0.50	0 ± -0.50	225	181.4
SR 170 SW	170	260	57	57	55	0 ± -0.025	0 ± -0.035	+0.35 -0.025	0 ± -0.50	0 ± -0.50	250	194.3
SR 180 SW	180	280	64	64	61	0 ± -0.025	0 ± -0.035	+0.35 -0.025	0 ± -0.50	0 ± -0.50	260	205.5
SR 190 SW	190	290	64	64	62	0 ± -0.030	0 ± -0.035	+0.35 -0.025	0 ± -0.50	0 ± -0.50	275	211.8
SR 200 SW	200	310	70	70	66	0 ± -0.030	0 ± -0.035	+0.35 -0.025	0 ± -0.60	0 ± -0.60	290	229.2

d	S	FATTORI DI CARICO RADIALE RADIAL LOAD FACTORS		r1	r2	DIMENSIONI DI MONTAGGIO MOUNTING DIMENSIONS				PESO IN Kg. WEIGHT Kg.
		Dinamico Dynamic C	Statico Static Co			da max.	db max.	DA min.	DB min.	
		KN		mm.				Kg.		
25	1	89	225	0.6	- 0.2	30.1	39.5	34	43	0.14
28	1	100	270	1.0	- 0.3	34.4	42	40	47.5	0.18
30	2	110	285	1.0	- 0.3	34.6	45	40.5	50.5	0.22
32	2.5	125	320	1.0	- 0.3	37.9	47.5	44	54	0.24
35	2	135	340	1.0	- 0.3	41.1	50	47	57	0.28
40	1.5	160	400	1.0	- 0.3	45.5	54	52	61	0.34
45	1.5	190	470	1.0	- 0.3	51.7	60	58	67	0.43
50	4	215	540	1.0	- 0.3	57.9	67	65	75	0.47
55	4	250	630	1.5	- 0.6	60.7	71	70	81	0.70
60	5	285	710	1.5	- 0.6	66.9	77	76	87	0.75
65	5	315	790	1.5	- 0.6	74.4	83	84	93	0.80
70	7	360	900	1.5	- 0.6	80.9	92	90	104	1.0
75	7	395	980	1.5	- 0.6	84.7	95	94	107	1.1
80	10	450	1120	1.5	- 0.6	88	104	99	117	1.6
85	10	495	1240	1.5	- 0.6	94.4	109	105	122	1.7
90	11	550	1380	2.0	- 0.6	100.8	118	112	132	2.2
95	8	610	1530	2.0	- 0.6	105.4	119	117	132	2.3
100	12	670	1680	2.0	- 0.6	112	128	123	142	2.4
105	14	740	1850	2.5	- 0.6	116.8	137	129	152	3.0
110	15	810	2020	2.5	- 0.6	123.2	146	135	162	3.7
120	17	955	2390	2.5	- 0.6	132.9	155	145	172	4.0
130	20	1240	3110	2.5	- 0.6	143.9	174	158	192	6.0
140	20	1310	3270	2.5	- 0.6	156.9	184	171	202	6.4
150	21	1490	3730	3.0	- 1.0	167.1	194	184	216	7.9
160	21	1690	4240	3.0	- 1.0	177.7	206	195	228	9.6
170	27	2080	5200	3.0	- 1.0	190.4	228	208	253	13.0
180	21	2440	6100	3.0	- 1.0	201.7	240	220	263	17.5
190	29	2620	6560	3.0	- 1.0	207.9	252	226	278	18.0
200	26	2940	7360	3.0	- 1.0	224.1	268	244	293	23.0

DISPONIBILITA' E PREZZO A RICHIESTA

AVAILABILITY AND PRICE UPON REQUEST

non richiedenti manutenzione/maintenance free

**SR...AW**  
(GX...F; GE...AW; GX...T)

SNODI SFERICI ASSIALI

NON RICHIEDENTI MANUTENZIONE  
ACCOPIAMENTO : CROMO DURO SU PTFE

ANGULAR CONTACT SPHERICAL PLAIN BEARINGS

MAINTENANCE FREE  
COUPLING:HARD CHROMIUM /PTFE

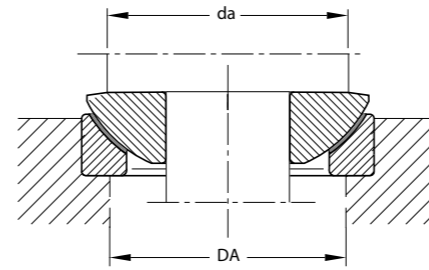
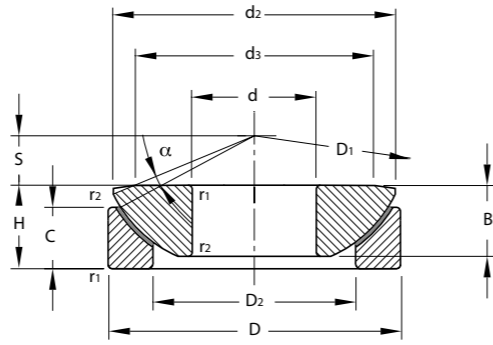

SIGLA CODE	d	D	H	B	C	TOLLERANZA TOLERANCE					D1	D2	d2	d3
						d	D	H	B	C				
mm.														
SR 10 AW	10	30	9.5	7.5	7	0 + -0.008	0 + -0.009	0 + -0.30	0 + -0.24	0 + -0.24	32	15.5	27.5	21
SR 12 AW	12	35	13	9.5	9.3	0 + -0.008	0 + -0.011	0 + -0.30	0 + -0.24	0 + -0.24	37	18	32	24
SR 15 AW	15	42	15	11	10.8	0 + -0.008	0 + -0.011	0 + -0.30	0 + -0.24	0 + -0.24	45	22.5	38.9	29
SR 17 AW	17	47	16	11.8	11.2	0 + -0.008	0 + -0.011	0 + -0.30	0 + -0.24	0 + -0.24	50	27	43.4	34
SR 20 AW	20	55	20	14.5	13.8	0 + -0.010	0 + -0.013	0 + -0.30	0 + -0.24	0 + -0.24	60	31	50	40
SR 25 AW	25	62	22.5	16.5	16.7	0 + -0.010	0 + -0.013	0 + -0.30	0 + -0.24	0 + -0.24	66	34.5	58.5	45
SR 30 AW	30	75	26	19	19	0 + -0.010	0 + -0.013	0 + -0.30	0 + -0.24	0 + -0.24	80	42	69	56
SR 35 AW	35	90	28	22	20.7	0 + -0.012	0 + -0.015	0 + -0.30	0 + -0.24	0 + -0.24	98	50.5	84	66
SR 40 AW	40	105	32	27	21.5	0 + -0.012	0 + -0.015	0 + -0.30	0 + -0.24	0 + -0.24	114	59	98	78
SR 45 AW	45	120	36.5	31	25.5	0 + -0.012	0 + -0.015	0 + -0.30	0 + -0.24	0 + -0.24	130	67	112	89
SR 50 AW	50	130	42.5	33.5	30.5	0 + -0.012	0 + -0.018	0 + -0.30	0 + -0.24	0 + -0.24	140	70	122.5	98
SR 60 AW	60	150	45	37	34	0 + -0.015	0 + -0.018	0 + -0.30	0 + -0.30	0 + -0.30	160	84	140	108
SR 70 AW	70	160	50	42	36.5	0 + -0.015	0 + -0.025	0 + -0.30	0 + -0.30	0 + -0.30	170	94.5	149.5	121
SR 80 AW	80	180	50	43.5	38	0 + -0.015	0 + -0.025	0 + -0.30	0 + -0.30	0 + -0.30	194	107.5	168	130
SR 100 AW	100	210	59	51	46	0 + -0.020	0 + -0.030	0 + -0.40	0 + -0.40	0 + -0.40	220	127	195.5	155
SR 120 AW	120	230	64	53.5	50	0 + -0.020	0 + -0.030	0 + -0.40	0 + -0.40	0 + -0.40	245	145	214	170
SR 140 AW	140	260	72	61	54	0 + -0.025	0 + -0.035	0 + -0.50	0 + -0.50	0 + -0.50	272	177	244	198
SR 160 AW	160	290	77	66	58	0 + -0.025	0 + -0.035	0 + -0.50	0 + -0.50	0 + -0.50	310	200	272	213
SR 180 AW	180	320	86	74	62	0 + -0.025	0 + -0.040	0 + -0.50	0 + -0.50	0 + -0.50	340	225	300	240
SR 200 AW	200	340	87	80	66	0 + -0.030	0 + -0.040	0 + -0.60	0 + -0.60	0 + -0.60	358	247	321	265
SR 220 AW	220	370	97	82	67	0 + -0.030	0 + -0.040	0 + -0.60	0 + -0.60	0 + -0.60	388	265	350	289
SR 240 AW	240	400	103	87	73	0 + -0.030	0 + -0.040	0 + -0.60	0 + -0.60	0 + -0.60	420	294	382	314
SR 260 AW	260	430	115	95	80	0 + -0.035	0 + -0.045	0 + -0.70	0 + -0.70	0 + -0.70	449	317	409	336
SR 280 AW	280	460	110	100	85	0 + -0.035	0 + -0.045	0 + -0.70	0 + -0.70	0 + -0.70	480	337	445	366
SR 300 AW	300	480	110	100	90	0 + -0.035	0 + -0.045	0 + -0.70	0 + -0.70	0 + -0.70	490	356	460	388
SR 320 AW	320	520	116	105	91	0 + -0.040	0 + -0.050	0 + -0.80	0 + -0.80	0 + -0.80	540	380	500	405
SR 340 AW	340	540	116	105	91	0 + -0.040	0 + -0.050	0 + -0.80	0 + -0.80	0 + -0.80	550	380	510	432
SR 360 AW	360	560	125	115	95	0 + -0.040	0 + -0.050	0 + -0.80	0 + -0.80	0 + -0.80	575	400	535	452

d	S	ANGOLO DI OSCILLAZIONE $\alpha$ SWINGING ANGLE $\alpha$	FATTORI DI CARICO ASSIALE AXIAL LOADS FACTORS		r1	r2	DIMENSIONI DI MONTAGGIO MOUNTING DIMENSIONS		PESO IN Kg. WEIGHT Kg.
			Dinamico Dynamic C	Statico Static Co			da max.	DA min.	
mm.		$\alpha^\circ$	KN		mm.		Kg.		
10	7	10	45	120	0.6	- 0.2	21	18.5	0.04
12	8	9	65	165	0.6	- 0.2	24	21.5	0.07
15	10	7	95	235	0.6	- 0.2	29	26	0.12
17	11	6	110	275	0.6	- 0.2	34	30.5	0.16
20	12.5	6	150	380	1.0	- 0.3	40	38	0.25
25	14	7	245	600	1.0	- 0.3	45	39	0.38
30	17.5	6	335	820	1.0	- 0.3	56	49	0.65
35	22	6	490	1200	1.0	- 0.3	66	57	1.00
40	24.5	6	675	1640	1.0	- 0.3	78	64	1.60
45	27.5	6	915	2240	1.0	- 0.3	89	74	2.40
50	30	5	1040	2550	1.0	- 0.3	98	75	3.30
60	35	7	1360	3470	1.0	- 0.3	108	92	4.50
70	35	6	1640	4180	1.0	- 0.3	121	102	5.50
80	42.5	6	2030	5180	1.0	- 0.3	130	115	7.00
100	45	7	2230	5940	1.0	- 0.3	155	141	10.50
120	52.5	8	2610	6960	1.0	- 0.3	170	162	13.00
140	52.5	6	3120	8300	1.5	- 0.6	198	187	18.00
160	65	7	3380	9560	1.5	- 0.6	213	211	23.00
180	67.5	8	3910	11050	1.5	- 0.6	240	236	31.00
200	70	8	4950	13990	1.5	- 0.6	265	259	34.00
220	75	7	4640	13110	1.5	- 0.6	289	279	44.50
240	77.5	6	5500	15560	1.5	- 0.6	314	309	55.00
260	82.5	7	6190	17510	1.5	- 0.6	336	332	69.00
280	80	4	8280	23400	3.0	- 1.0	366	355	82.00
300	80	3.5	9010	25480	3.0	- 1.0	388	375	87.00
320	95	4	11360	33260	4.0	- 1.1	405	402	109.00
340	95	4	11570	33880	4.0	- 1.1	432	402	114.00
360	95	4	12850	37630	4.0	- 1.1	452	422	129.00

DISPONIBILITA' E PREZZO A RICHIESTA  
AVAILABILITY AND PRICE UPON REQUEST

# COMPONENTI PNEUMATICA PNEUMATIC COMPONENTS



TERMINALI CON ACCOPPIAMENTO ACCIAIO/BRONZO CON FILETTATURA INTERNA ED ESTERNA  
RICHIEDENTI MANUTENZIONE  
*ROD ENDS WITH STEEL/BRONZE COUPLING WITH INTERNAL  
AND EXTERNAL THREADS WITH MAINTENANCE*

97-98

TERMINALI CON ACCOPPIAMENTO ACCIAIO/PTFE CON FILETTATURA INTERNA ED ESTERNA  
ESENTI DA MANUTENZIONE  
*ROD ENDS WITH STEEL/PTFE COUPLING WITH INTERNAL  
AND EXTERNAL THREADS MAINTENANCE FREE*

99-100

FORCELLE, PERNI E CLIPS SERIE ISO 8140  
FORCELLE, PERNI E CLIPS SERIE UNI 1676- DIN 71752  
*FORKS, PINS, CLIPS SERIES ISO 8140  
FORKS, PINS, CLIPS SERIES - SERIES UNI 1676- DIN 71752*

101-102

FORCELLE, PERNI E CLIPS SERIE CNOMO,  
FORCELLE, PERNI E CLIPS SERIE CETOP  
*FORKS, PINS, CLIPS SERIES CNOMO  
FORKS, PINS, CLIPS SERIES - SERIES CETOP*

103-104

SNODI AUTOALLINEANTI DIRITTI  
SNODI AUTOALLINEANTI ANGOLARI  
*SELF-ALIGNING JOINTS  
ANGULAR JOINTS*

105-106

## TABELLA COMPARATIVA TERMINALI PAVARINI COMPONENTS CROSS REFERENCE ROD-ENDS PAVARINI COMPONENTS

<b>pavarini</b> COMPONENTS	<b>SKF</b>	<b>INA</b>
TFI...PB	SIKAC...M	GIKR...-PB
TFE...PB	SAKAC...M	GAKR...-PB
TFI...PW	SIKB...F	GIKR...-PW
TFE...PW	SAKB...F	GAKR...-PW





## IKI Per un'automazione più efficiente IKI - for high performance automation



Scatola personalizzata contenente un pezzo protetto in busta di plastica (Polietilene)

Genuine brand box with plastic bag (Polyethylene) for each part



### Serie che richiede manutenzione

Corpo in acciaio stampato zincato con ingrassatore  
Anello esterno in bronzo  
Anello interno in acciaio temprato, rettificato e lucidato.  
**E' consigliabile lubrificare periodicamente al fine di garantire una lunga durata ed un migliore funzionamento.**

### Requiring maintenance range

Forged zinc plated steel housing with grease nipple  
Bronze outer ring  
Rectified, polished and hardened steel inner ring.  
**Regular frequency of lubrication is necessary to obtain the desired performance and service life.**



### Serie che non richiede manutenzione

Corpo in acciaio stampato zincato  
Anello esterno in bronzo rivestito in PTFE  
Anello interno in acciaio temprato, rettificato e lucidato

### Maintenance-free range

Forged zinc plated steel housing  
Bronze outer ring coated with PTFE  
Rectified, polished and hardened steel inner ring.



Serie completa di forcelle in acciaio zincato  
Complete range of zinc plated steel yokes

richiedenti manutenzione/requiring maintenance

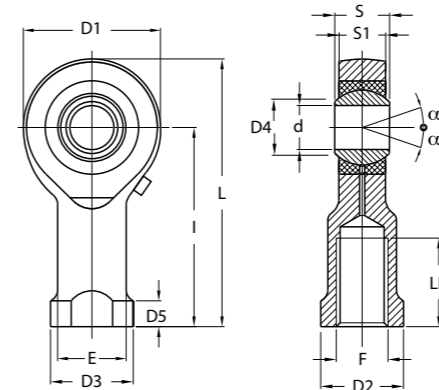

## TFI...PB

## TFI...PB PASSO / LEAD MB

(SIKAC...M; SIKAC...M/VZ019; GIKR...-PB)

TERMINALI A SNODO  
ISO 12240-4, SERIE K - ISO 6126  
RILUBRIFICABILI  
ACCOPIAMENTO: ACCIAIO SU BRONZO

ROD ENDS  
ISO 12240-4, SERIES K - ISO 6126  
WITH GREASE NIPPLE  
COUPLING: STEEL/BRONZE

SIGLA ARTICLE	d		TOLLERANZA TOLERANCE		S	D4	I	D1	D3	E	D2	D5	S1	L	LF min	F	FATTORI DI CARICO LIMITE LOAD FACTORS		GIUOCO SNODO RADIALE RADIAL CLEARANCE	ANGOLO DI OSCILLAZIONE C SWING ANGLE C	PESO IN Kg WEIGHT Kg
	d	S	Dinamico Dynamic C	Statico Static Co																	
	mm.																				
TFI 5 PB (1)	5	0 + +0.012	0 + -0.12	8	7.7	27	16	11	9	9	4	6	35	14	M 5X0.8	3.3	4.1	0. - 0.035	13	0.01	
TFI 6 PB (1)	6	0 + +0.012	0 + -0.12	9	9	30	18	13	10	11	5	6.7	39	14	M 6X1	4.3	5.3	0. - 0.035	13	0.01	
TFI 8 PB (1)	8	0 + +0.015	0 + -0.12	12	10.4	36	22	16	12.5	14	5	9	47	17	M 8X1.25	6.8	9.2	0. - 0.035	14	0.03	
TFI 10 PB (1)	10	0 + +0.015	0 + -0.12	14	12.9	43	26	19	15	17	6.5	10.5	56	21	M10X1.5	10	12	0. - 0.035	13	0.08	
TFI 12 PB (1)	12	0 + +0.018	0 + -0.12	16	15.4	50	30	22	17.5	19	6.5	12	65	24	M12X1.75	13	17	0. - 0.035	13	0.12	
TFI 14 PB (1)	14	0 + +0.018	0 + -0.12	19	16.9	57	34	25	20	22	8	13.5	74	27	M14X2	17	22	0. - 0.035	16	0.14	
TFI 16 PB	16	0 + +0.018	0 + -0.12	21	19.4	64	38	27	22	22	8	15	83	33	M16X2	21	28	0. - 0.035	15	0.22	
TFI 18 PB	18	0 + +0.018	0 + -0.12	23	21.9	71	42	31	25	27	10	16.5	92	36	M18X1.5	26	34	0. - 0.035	15	0.32	
TFI 20 PB	20	0 + +0.021	0 + -0.12	25	24.4	77	48	34	27.5	30	10	18	100	40	M20X1.5	31	40	0. - 0.035	14	0.43	
TFI 22 PB	22	0 + +0.021	0 + -0.12	28	25.8	84	50	37	30	32	12	20	109	43	M22X1.5	38	50	0. - 0.035	15	0.61	
TFI 25 PB	25	0 + +0.021	0 + -0.12	31	29.6	94	60	42	33.5	36	12	22	124	48	M24X2	47	63	0. - 0.035	15	0.81	
TFI 28 PB	28	0 + +0.021	0 + -0.12	35	32.3	103	66	46	37	41	12	25	136	53	M27X2	59	81	0. - 0.035	15	1.20	
TFI 30 PB	30	0 + +0.021	0 + -0.12	37	34.8	110	70	50	40	41	15	25	145	56	M30X2	63	86	0. - 0.035	17	1.40	
TFI 30 PB M27x2	30	0 + +0.021	0 + -0.12	37	34.8	110	70	50	40	41	15	25	145	60	M27X2	63	86	0. - 0.035	17	1.40	
TFI 35 PB M36x2 (2)	35	0 + +0.021	0 + -0.12	43	39.0	126	80	58	46	50	17	28	166	58	M36X2	79	109	0. - 0.035	20	1.70	

### VERSIONE CON FILETTO TIPO CETOP - PASSO MB - VERSION WITH THREAD CETOP TYPE - LEAD MB

TFI 10 PB-MB (1)	10	0 + +0.015	0 + -0.12	14	12.9	43	26	19	15	17	6.5	10.5	56	21	M10X1.25	10	12	0. - 0.035	10	0.08
TFI 12 PB-MB (1)	12	0 + +0.018	0 + -0.12	16	15.4	50	30	22	17.5	19	6.5	12	65	24	M12X1.25	13	17	0. - 0.035	12	0.12
TFI 16 PB-MB	16	0 + +0.018	0 + -0.12	21	19.4	64	38	27	22	22	8	15	83	33	M16X1.5	21	28	0. - 0.035	14	0.22

(1) RILUBRIFICABILE MEDIANTE OLITATORE SUL GAMBO

(2) DISPONIBILITÀ A RICHIESTA

(\*) NEL CASO DI RICHIESTA CON FILETTATURA SINISTRORSA AGGIUNGERE NEL COD. ART. LA LETTERA "L" ES. **TFIL...** DISPONIBILITÀ E PREZZO A RICHIESTA.

(1) LUBRICATABLE BY A OIL NIPPLE ON THE STEM

(2) UPON REQUEST

(\*) WHEN REQUIRING A LEFT - END THREAD, ADD THE LETTER "L" IN THE ARTICLE CODE (e.g.: **TFIL...**). AVAILABILITY AND PRICE UPON REQUEST.

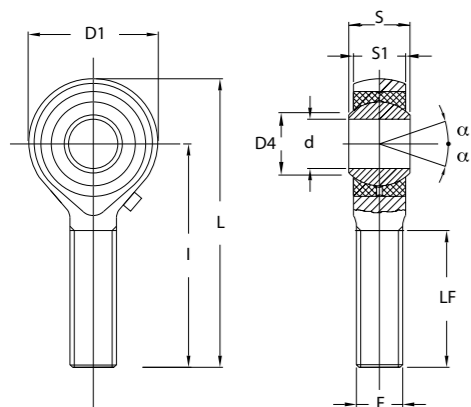

**TFE...PB**  
(SAKAC...M; GAKR...-PB)

TERMINALI A SNODO  
ISO 12240-4, SERIE K - ISO 6126  
RILUBRIFICABILI  
ACCOPIAMENTO : ACCIAIO SU BRONZO

ROD ENDS  
ISO 12240-4, SERIES K - ISO 6126  
WITH GREASE NIPPLE  
COUPLING: STEEL/BRONZE

SIGLA ARTICLE	d	TOLLERANZA TOLERANCE		S	D4	I	D1	S1	L	LF min	F	FATTORI DI CARICO LIMITE LOAD FACTORS		GIUOCO SNODO RADIALE RADIAL CLEARANCE	ANGOLO DI OSCILLAZIONE α SWINGING ANGLE α°	PESO IN Kg WEIGHT Kg
		d	S									Dinamico Dynamic C	Statico Static Co			
mm.																
TFE 5 PB	5	0+ +0.012	0+ -0.12	8	7.7	33	18	6	41	20	M 5X0.8	3.3	4.1	0 - 0.035	13	0.01
TFE 6 PB	6	0+ +0.012	0+ -0.12	9	9.0	36	20	6.7	45	22	M 6X1	4.3	5.3	0 - 0.035	13	0.02
TFE 8 PB	8	0+ +0.015	0+ -0.12	12	10.4	42	24	9	53	25	M 8X1.25	6.8	9.2	0 - 0.035	14	0.03
TFE 10 PB	10	0+ +0.015	0+ -0.12	14	12.9	48	28	10.5	61	29	M10X1.5	10	12	0 - 0.035	13	0.05
TFE 12 PB	12	0+ +0.015	0+ -0.12	16	15.4	54	32	12	69	33	M12X1.75	13	17	0 - 0.035	13	0.08
TFE 14 PB	14	0+ +0.018	0+ -0.12	19	16.9	60	36	13.5	77	36	M14X2	17	22	0 - 0.035	16	0.12
TFE 16 PB	16	0+ +0.018	0+ -0.12	21	19.4	66	42	15	85	40	M16X2	21	28	0 - 0.035	15	0.18
TFE 18 PB	18	0+ +0.018	0+ -0.12	23	21.9	72	44	16.5	93	44	M18X1.5	26	34	0 - 0.035	15	0.26
TFE 20 PB	20	0+ +0.021	0+ -0.12	25	24.4	78	50	18	101	47	M20X1.5	31	40	0 - 0.035	14	0.34
TFE 22 PB	22	0+ +0.021	0+ -0.12	28	25.8	84	54	20	109	51	M22X1.5	38	50	0 - 0.035	15	0.43
TFE 25 PB	25	0+ +0.021	0+ -0.12	31	29.5	94	60	22	124	57	M24X2	47	63	0 - 0.035	15	0.65
TFE 28 PB	28	0+ +0.021	0+ -0.12	35	32.3	103	66	25	136	62	M27X2	59	81	0 - 0.035	15	0.87
TFE 30 PB	30	0+ +0.021	0+ -0.12	37	34.8	110	70	25	145	66	M30X2	63	86	0 - 0.035	17	1.00

(\*) NEL CASO DI RICHIESTA CON FILETTATURA SINISTRORSA AGGIUNGERE NEL COD. ART. LA LETTERA "L" ES. **TFEL...** DISPONIBILITA' E PREZZO A RICHIESTA.

(\*) WHEN REQUIRING A LEFT - END THREAD, ADD THE LETTER "L" IN THE ARTICLE CODE (e.g.: **TFEL...**). AVAILABILITY AND PRICE UPON REQUEST.

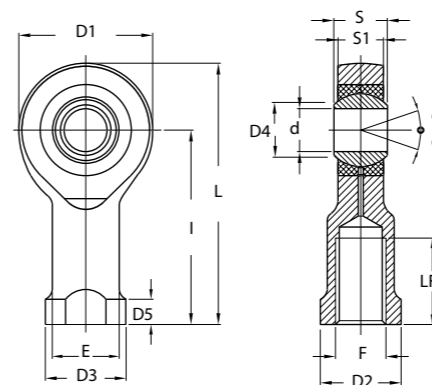

**TFI...PW**  
**TFI...PW** (PASSO - LEAD MB)  
(SIKB...F; SIKB...F/VZ019; GIKR...-PW)

TERMINALI A SNODO  
ISO 12240-4, SERIE K-ISO 6126  
ESENTI MANUTENZIONE  
ACCOPIAMENTO : ACCIAIO SU PTFE

ROD ENDS  
ISO 12240-4, SERIES K-ISO 6126  
MAINTENANCE FREE  
COUPLING: STEEL/PTFE

SIGLA ARTICLE	d	TOLLERANZA TOLERANCE		S	D4	I	D1	D3	E	D2	D5	S1	L	LF min	F	FATTORI DI CARICO LIMITE LOAD FACTORS		GIUOCO SNODO RADIALE RADIAL CLEARANCE	ANGOLO DI OSCILLAZIONE α SWINGING ANGLE α°	PESO IN Kg WEIGHT Kg
		d	S													Dinamico Dynamic C	Statico Static Co			
mm.																				
TFI 5 PW	5	0+ +0.012	0+ -0.12	8	7.7	27	18	12	9	10	4	7.5	36	8	M 5X0.8	3.6	4.6	0 - 0.035	13	0.01
TFI 6 PW	6	0+ +0.012	0+ -0.12	9	8.9	30	20	13	10	10	5	7.5	40	9	M 6X1	4.7	5.2	0 - 0.035	13	0.01
TFI 8 PW	8	0+ +0.015	0+ -0.12	12	10.3	36	24	16	12.5	13	5	9.5	48	12	M 8X1.25	7.6	8.2	0 - 0.035	14	0.03
TFI 10 PW	10	0+ +0.015	0+ -0.12	14	12.9	43	30	19	15	16	6.5	11.5	58	15	M10X1.5	12	15	0 - 0.035	13	0.08
TFI 12 PW	12	0+ +0.018	0+ -0.12	16	15.4	50	34	22	17.5	18	6.5	12.5	67	18	M12X1.75	14	19	0 - 0.035	13	0.12
TFI 14 PW	14	0+ +0.018	0+ -0.12	19	16.8	57	38	25	20	21	8	14.5	76	21	M14X2	19	24	0 - 0.035	16	0.14
TFI 16 PW	16	0+ +0.018	0+ -0.12	21	19.3	64	42	27	22	24	8	15.5	85	24	M16X2	23	29	0 - 0.035	15	0.22
TFI 18 PW	18	0+ +0.018	0+ -0.12	23	21.8	71	46	31	25	27	10	17.5	94	27	M18X1.5	29	34	0 - 0.035	15	0.32
TFI 20 PW	20	0+ +0.021	0+ -0.12	25	24.3	77	50	34	27.5	30	10	18.5	102	30	M20X1.5	34	40	0 - 0.035	14	0.43
TFI 22 PW	22	0+ +0.021	0+ -0.12	28	25.8	84	56	37	30	34	12	21	112	33	M22X1.5	42	50	0 - 0.035	15	0.61
TFI 25 PW	25	0+ +0.021	0+ -0.12	31	29.5	94	60	42	33.5	36	12	23	124	36	M24X2	52	57	0 - 0.035	15	0.81
TFI 28 PW	28	0+ +0.021	0+ -0.12	35	32.3	103	66	46	37	41	14	26	136	41	M27X2	66	69	0 - 0.035	15	1.20
TFI 30 PW	30	0+ +0.021	0+ -0.12	37	34.8	110	70	50	40	46	15	27	145	45	M30X2	73	77	0 - 0.035	17	1.40
TFI 30 PW M27x2	30	0+ +0.021	0+ -0.12	37	34.8	110	70	50	40	46	15	27	145	60	M27X2	73	77	0 - 0.035	17	1.40
TFI 35 PW M36x2	35	0+ +0.021	0+ -0.12	43	39.0	126	80	58	46	50	17	28	166	58	M36X2	94	97	0 - 0.035	20	1.70

VERSIONE CON FILETTO TIPO CETOP - PASSO MB - VERSION WITH THREAD CETOP TYPE - LEAD MB

TFI 10 PW-MB	10	0+ +0.015	0+ -0.12	14	12.9	43	30	19	15	16	6.5	11.5	58	15	M10X1.25	12	15	0 - 0.035	10	0.08
TFI 12 PW-MB	12	0+ +0.018	0+ -0.12	16	15.4	50	34	22	17.5	18	6.5	12.5	67	18	M12X1.25	14	19	0 - 0.035	12	0.12
TFI 16 PW-MB	16	0+ +0.018	0+ -0.12	21	19.3	64	42	27	22	24	8	15.5	85	24	M16X1.5	23	29	0 - 0.035	14	0.22

(\*) NEL CASO DI RICHIESTA CON FILETTATURA SINISTRORSA AGGIUNGERE NEL COD. ART. LA LETTERA "L" ES. **TFIL...** DISPONIBILITA' E PREZZO A RICHIESTA.

(\*) WHEN REQUIRING A LEFT - END THREAD, ADD THE LETTER "L" IN THE ARTICLE CODE (e.g.: **TFIL...**). AVAILABILITY AND PRICE UPON REQUEST.

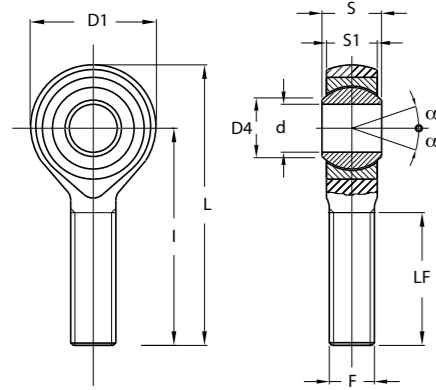

**TFE...PW**  
(SAKB...F; GAKR...-PW)

TERMINALI A SNODO  
ISO 12240-4, SERIE K - ISO 6126  
ESENTI MANUTENZIONE  
ACCOPIAMENTO : ACCIAIO SU PTFE

ROD ENDS  
ISO 12240-4, SERIE K - ISO 6126  
MAINTENANCE FREE  
COUPLING: STEEL/PTFE

SIGLA ARTICLE	d	TOLLERANZA TOLERANCE		S	D4	I	D1	S1	L	LF min	F	FATTORI DI CARICO LIMITE LOAD FACTORS		GIUOCO SNODO RADIALE RADIAL CLEARANCE	ANGOLO DI OSCILLAZIONE α SWINGING ANGLE α	PESO IN Kg. WEIGHT Kg.
		d	S									C Dinamico Dynamic	C <sub>0</sub> Statico Static			
		mm.										KN	mm.	gradi		
TFE 5 PW	5	0+ +0.012	0+ -0.12	8	7.7	33	18	7.5	42	19	M 5X0.8	3.6	3.9	0 - 0.035	13	0.01
TFE 6 PW	6	0+ +0.012	0+ -0.12	9	8.9	36	20	7.5	46	21	M 6X1	4.7	5.2	0 - 0.035	13	0.02
TFE 8 PW	8	0+ +0.015	0+ -0.12	12	10.3	42	24	9.5	54	25	M 8X1.25	7.6	8.2	0 - 0.035	14	0.03
TFE 10 PW	10	0+ +0.015	0+ -0.12	14	12.9	48	30	11.5	63	28	M 10X1.5	12	15	0 - 0.035	13	0.05
TFE 12 PW	12	0+ +0.018	0+ -0.12	16	15.4	54	34	12.5	71	32	M 12X1.75	14	19	0 - 0.035	13	0.08
TFE 14 PW	14	0+ +0.018	0+ -0.12	19	16.8	60	38	14.5	79	36	M 14X2	19	24	0 - 0.035	16	0.12
TFE 16 PW	16	0+ +0.018	0+ -0.12	21	19.3	66	42	15.5	87	37	M 16X2	23	29	0 - 0.035	15	0.18
TFE 18 PW	18	0+ +0.018	0+ -0.12	23	21.8	72	46	17.5	95	41	M 18X1.5	29	34	0 - 0.035	15	0.26
TFE 20 PW	20	0+ +0.021	0+ -0.12	25	24.3	78	50	18.5	103	45	M 20X1.5	34	40	0 - 0.035	14	0.34
TFE 22 PW	22	0+ +0.021	0+ -0.12	28	25.8	84	56	21	112	48	M 22X1.5	42	50	0 - 0.035	15	0.43
TFE 25 PW	25	0+ +0.021	0+ -0.12	31	29.5	94	60	23	124	55	M 24X2	52	57	0 - 0.035	15	0.65
TFE 28 PW	28	0+ +0.021	0+ -0.12	35	32.3	103	66	26	136	62	M 27X2	66	69	0 - 0.035	15	0.87
TFE 30 PW	30	0+ +0.021	0+ -0.12	37	34.8	110	70	27	145	66	M 30X2	73	77	0 - 0.035	17	1.07

(\*) NEL CASO DI RICHIESTA CON FILETTATURA SINISTRORSA AGGIUNGERE NEL COD.ART.LA LETTERA " L" ES. **TFEL...** DISPONIBILITA' E PREZZO A RICHIESTA.

(\*) WHEN REQUIRING A LEFT - END THREAD, ADD THE LETTER "L" IN THE ARTICLE CODE, (e.g.: **TFEL...**). AVAILABILITY AND PRICE UPON REQUEST.

**FORCELLA CON FORO FILETTATO**  
**YOKES**

NORMA ISO 8140  
MATERIALE ACCIAIO  
9SMn Pb 23 R 50 Kg/mm<sup>2</sup>

STANDARD ISO 8140  
STEEL MATERIAL  
9SMn Pb 23 R 50 Kg/mm<sup>2</sup>

SIGLA ARTICLE	F	ALESAGGIO BORE	A (B13)	B	d (H9)	D	E	L	L1	N	PESO IN Kg. WEIGHT Kg.
FFF 1760	M 4X0.7	8/10	4	8	4	8	6	21	16	8	0.010
FFF 1762	M 6X1	12/16	6	12	6	10	9	31	24	12	0.015
FFF 1764	M 8X1.25	20	8	16	8	14	12	42	32	16	0.030
FFF 1766	M10X1.25	25/32	10	20	10	18	15	52	40	20	0.070
FFF 1768	M12X1.25	40	12	24	12	20	18	62	48	24	0.110
FFF 1770	M16X1.5	50/63	16	32	16	26	24	83	64	32	0.280
FFF 1772	M20X1.5	80/100	20	40	20	34	30	105	80	40	0.570
FFF 1774 (1)	M24X2	125	25	50	25	42	36	132	100	50	1.020
FFF 1775	M27X2	125	30	55	30	48	37	148	110	54	1.470
FFF 1776	M36X2	160/200	35	70	35	60	40	188	144	72	3.400

(1) FUORI NORMA - WITHOUT STANDARD

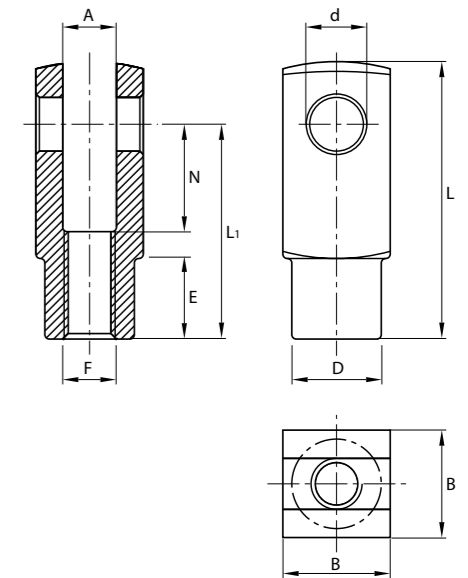

**PERNO PER FORCELLE**  
**CLEVIS PINS**

NORMA ISO 8140  
MATERIALE ACCIAIO  
9SMn Pb 23 R 50 Kg/mm<sup>2</sup>

STANDARD ISO 8140  
STEEL MATERIAL  
9SMn Pb 23 R 50 Kg/mm<sup>2</sup>

SIGLA ARTICLE	d X L	d1	L1	a	b	USATO PER FORCELLE ISO USED FORKS ISO	PESO IN Kg. WEIGHT Kg.
PPF 1778	10 X 25	9.6	20	1.5	1.1	M10X1.25	0.015
PPF 1780	12 X 30	11.5	24	2	1.1	M12X1.25	0.025
PPF 1782	16 X 39	15.2	32	2.4	1.1	M16X1.5	0.060
PPF 1784	20 X 48	19	41	2.9	1.3	M20X1.5	0.115
PPF 1786 (1)	25 X 60	23.9	50	3.7	1.3	M24X2	0.220
PPF 1787	30 X 65	28.5	56.5	3.4	1.6	M27X2	0.335
PPF 1788	35 X 84	33	70	5.4	1.6	M36X2	0.620

(1) FUORI NORMA - WITHOUT STANDARD

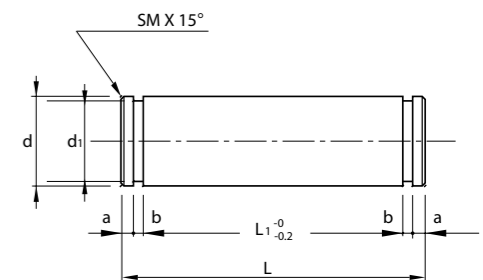

**CLIPS PER FORCELLE**  
**LOCKABLE PINS**

NORMA ISO 8140  
STANDARD ISO 8140

SIGLA ARTICLE	CLIPS-ISO	d1	A	B	L	L1	L2	PESO IN Kg. WEIGHT Kg.
SAF 1790	4	4	11	9	19	15	5	0.002
SAF 1792	6	6	16	14	28	23	6	0.005
SAF 1794	8	8	21	19	37	31	8	0.010
SAF 1796	10	10	26	23	46	39	10	0.010
SAF 1798	12	12	32	28	55	47	12	0.030
SAF 1800	16	16	40	36	72	62	14	0.060
SAF 1802	20	20	48	44	88	72	16	0.120

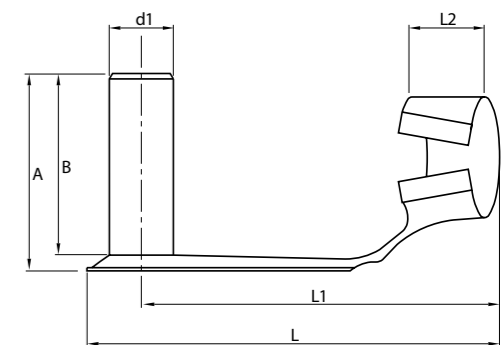

## FORCELLA CON FORO FILETTATO YOKES

DIN 71752  
MATERIALE ACCIAIO - 9SMn Pb 23 R 50 Kg/mm<sup>2</sup>

DIN 71752  
STEEL MATERIAL - 9SMn Pb 23 R 50 Kg/mm<sup>2</sup>

SIGLA ARTICLE	F	N	A (B13)	B	d (H9)	D	E	L	L1	PESO IN Kg. WEIGHT Kg.
FFF 12330	M 6X1	12	6	12	6	10	9	31	24	0.015
FFL 12330	M 6X1	24	6	12	6	10	9	43	36	0.020
FFF 12331	M 8X1.25	16	8	16	8	14	12	42	32	0.030
FFL 12331	M 8X1.25	32	8	16	8	14	12	58	48	0.050
FFF 12332	M10X1.5	20	10	20	10	18	15	52	40	0.070
FFL 12332	M10X1.5	40	10	20	10	18	15	72	60	0.100
FFF 12333	M12X1.75	24	12	24	12	20	18	62	48	0.115
FFL 12333	M12X1.75	48	12	24	12	20	18	88	72	0.160
FFF 12334	M14X2	28	14	27	14	24	23	72	56	0.175
FFL 12334	M14X2	56	14	27	14	24	23	101	85	0.250
FFF 12335	M16X2	32	16	32	16	26	24	83	64	0.280
FFL 12335	M16X2	64	16	32	16	26	24	115	96	0.400
FFF 12385	M18X2.5	36	18	36	18	30	27	94	72	0.400
FFF 12386	M20X2.5	40	20	40	20	34	30	105	80	0.555

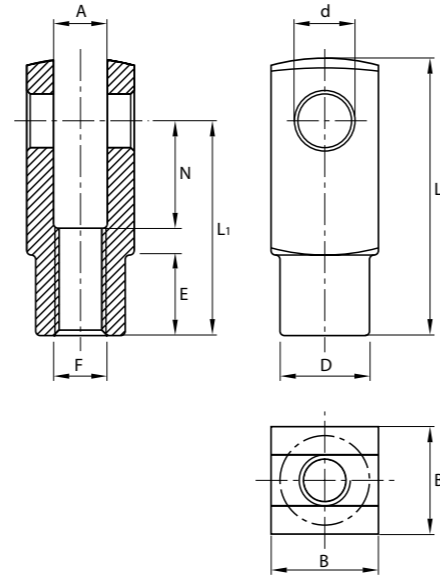

## FORCELLA CON FORO FILETTATO YOKES

NORMA CNOMO  
MATERIALE ACCIAIO - 9SMn Pb 23 R 50 Kg/mm<sup>2</sup>

STANDARD CNOMO  
STEEL MATERIAL - 9SMn Pb 23 R 50 Kg/mm<sup>2</sup>

SIGLA ARTICLE	ALESAGGIO BORE	F	A (B13)	B	B1	d (H9)	D	E	L	L1	N	PESO IN Kg. WEIGHT Kg.
FFF 12400	32	M10X1.5	11	22	22	8	18	14	45	36	16	0.007
FFF 12402	40/50	M16X1.5	18	36	26	12	26	17	64	51	25	0.190
FFF 12404	63/80	M20X1.5	22	45	34	16	34	18.5	80	63	33	0.440
FFF 12406	100/125	M27X2	30	63	42	20	42	30	105	85	40	0.935
FFF 12408	160/200	M36X2	40	80	50	25	50	45	140	115	40	1.750

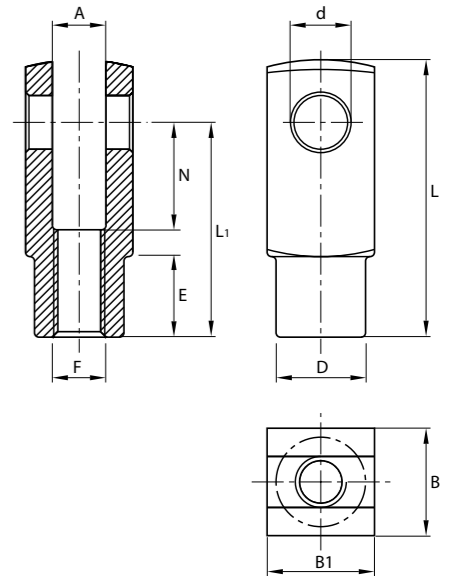

## PERNO CON TESTA CLEVIS

UNI EN 22341 - DIN 1434  
MATERIALE ACCIAIO - 9SMn Pb 23 R 50 Kg/mm<sup>2</sup>

UNI EN 22341 - DIN 1434  
STEEL MATERIAL - 9SMn Pb 23 R 50 Kg/mm<sup>2</sup>

SIGLA ARTICLE	d X L	H	D	d1	L1	PESO IN Kg. WEIGHT Kg.
PPF 12336	6 X 16	1.5	9	2	13	0.010
PPF 12337	8 X 20	2	12	2	17	0.010
PPF 12338	10 X 25	2	14	3	21.5	0.015
PPF 12339	12 X 30	3	16	3	26.5	0.030
PPF 12340	14 X 35	3	19	4	31	0.030
PPF 12341	16 X 40	3	20	4	36	0.050
PPF 12388	18 X 45	4	22	4	40	0.100
PPF 12389	20 X 50	4	26	4	43.5	0.130

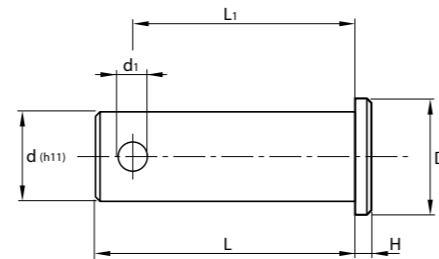

## PERNO PER FORCELLE CLEVIS PIN

NORMA CNOMO  
MATERIALE ACCIAIO - 9SMn Pb 23 R 50 Kg/mm<sup>2</sup>

STANDARD CNOMO  
STEEL MATERIAL - 9SMn Pb 23 R 50 Kg/mm<sup>2</sup>

SIGLA ARTICLE	PERNI CNOMO PINS CNOMO	d	L	D1	L1	a	b	PESO IN Kg. WEIGHT Kg.
PPF 12420	10	8	30	7.6	22	3	0.9	0.012
PPF 12422	16	12	45	11.5	36	3.5	1.1	0.040
PPF 12424	20	16	55	15.2	45	3.9	1.1	0.080
PPF 12426	27	20	75	19	63	4.9	1.3	0.185
PPF 12428	36	25	95	23.9	80	6.2	1.3	0.335

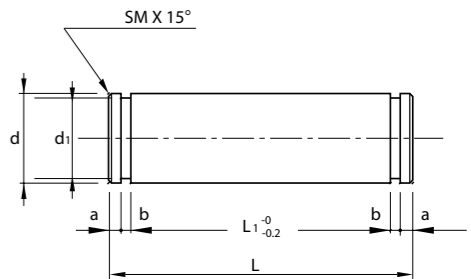

## CLIPS PER FORCELLE LOCKABLE PINS

DIN 71752

DIN 71752

SIGLA ARTICLE	d X L	d1	A	B	L	L1	L2	PESO IN Kg. WEIGHT Kg.
SAF 12342	6 X 12	6	16	14	28	23	6	0.005
SAL 12342	6 X 24	6	16	14	40	35	6	0.008
SAF 12343	8 X 16	8	22	18	37	31	8	0.010
SAL 12343	8 X 32	8	22	19	53	47	8	0.015
SAF 12344	10 X 20	10	26	23	46	39	10	0.010
SAL 12344	10 X 40	10	26	23	66	59	10	0.020
SAF 12345	12 X 24	12	32	28	55	47	12	0.030
SAL 12345	12 X 48	12	32	28	80	71	12	0.040
SAF 12346	14 X 28	14	32	30	62	51	14	0.050
SAF 12347	16 X 32	16	38	36	75	61	15	0.060
SAF 12390	20 X 40	20	47	44	95	77	16	0.120

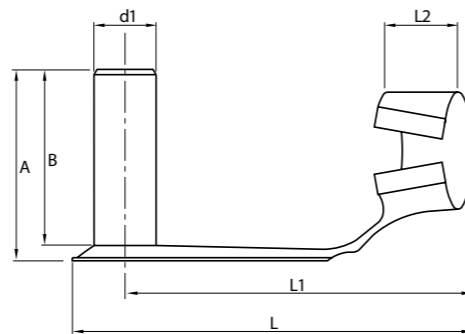

## CLIPS PER FORCELLE LOCKABLE PINS

NORMA CNOMO  
STANDARD CNOMO

SIGLA ARTICLE	CLIPS CNOMO	d1	A	B	L	L1	L2	PESO IN Kg. WEIGHT Kg.
SAF 12440	10	8	28	25	41	36	10	0.015
SAF 12442	16	12	44	39	60	50	12	0.040
SAF 12444	20	16	53	48	74	63	15	0.090
SAF 12446	27	20	73	66	98	81	19	0.195

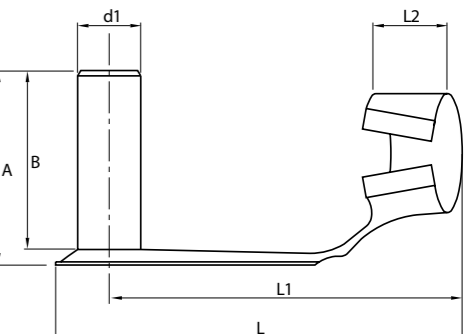

## FORCELLA CON FORO FILETTATO YOKES

NORMA CETOP RP 102 P  
MATERIALE ACCIAIO - 9SMn Pb 23 R 50 Kg/mm<sup>2</sup>

STANDARD CETOP RP 102 P  
STEEL MATERIAL - 9SMn Pb 23 R 50 Kg/mm<sup>2</sup>

SIGLA ARTICLE	F	ALESAGGIO BORE	A	B	d	D	E	L	L1	N	PESO IN Kg. WEIGHT Kg.
FFF 1722	M10X1.25	25/32	10	20	10	18	15	52	40	20	0.070
FFF 1724	M12X1.25	40	12	24	12	20	18	62	48	24	0.110
FFF 1726	M16X1.5	50/63	16	32	16	26	24	83	64	32	0.280
FFF 1728	M20X1.5	80/100	20	40	20	34	30	105	80	40	0.570
FFF 1730	M24X2	125	25	50	25	42	36	132	100	50	1.020
FFF 1732	M36X2	160/200	35	70	35	60	40	188	144	72	3.400

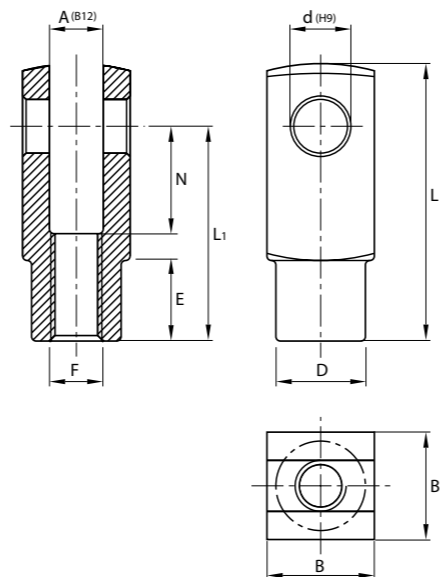

## PERNO PER FORCELLE CLEVIS PIN

NORMA CETOP  
MATERIALE ACCIAIO - 9SMn Pb 23 R 50 Kg/mm<sup>2</sup>

STANDARD CETOP  
STEEL MATERIAL - 9SMn Pb 23 R 50 Kg/mm<sup>2</sup>

SIGLA ARTICLE	d X L	d1	L1	a	b	USATO PER FORCELLE CETOP USED FOR FORKS CETOP	PESO IN Kg. WEIGHT Kg.
PPF 1734	10 X 25	9.6	20	1.5	1.1	M10X1.25	0.015
PPF 1736	12 X 30	11.5	24	2	1.1	M12X1.25	0.025
PPF 1738	16 X 39	15.2	32	2.4	1.1	M16X1.5	0.060
PPF 1740	20 X 48	19	40	2.9	1.3	M20X1.5	0.115
PPF 1742	25 X 60	23.9	50	3.7	1.3	M24X2	0.220
PPF 1744	35 X 84	28.6	70	5.4	1.3	M36X2	0.620

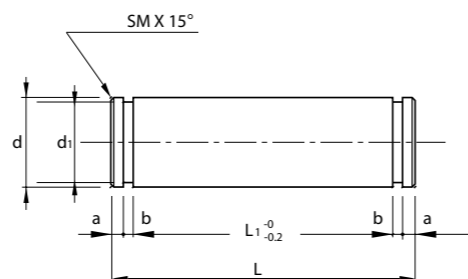

## CLIPS PER FORCELLE LOCKABLE PINS

NORMA CETOP  
STANDARD CETOP

SIGLA ARTICLE	CLIPS-PINS CETOP	d1	A	B	L	L1	L2	PESO IN Kg. WEIGHT Kg.
SAF 1746	10	10	26	23	46	39	10	0.010
SAF 1748	12	12	32	28	55	47	12	0.030
SAF 1750	16	16	40	36	72	62	14	0.060
SAF 1752	20	20	48	44	88	72	16	0.120

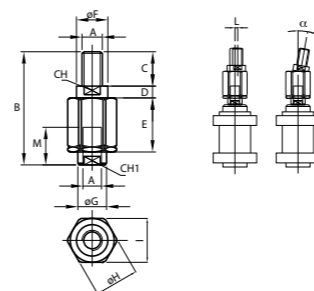
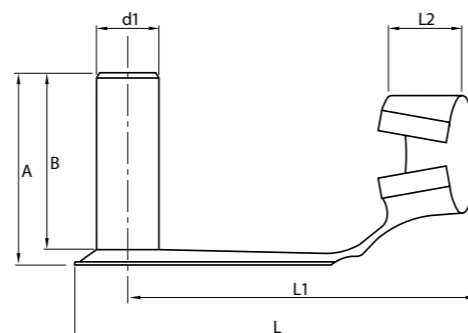

## SAU...

SNODI AUTOALLINEANTI  
PER CILINDRI PNEUMATICI  
MATERIALE: ACCIAIO ZINCATO  
SELF-ALIGNING JOINTS  
FOR PNEUMATIC CYLINDERS  
MATERIAL: GALVANIZED STEEL

SIGLA ARTICLE	A	B	C	D	E	F	G	H	I	L	M	CH	α	CH1	PESO IN Kg. WEIGHT Kg.
SAU 40006	M6 X1	35	10	3.5	17.5	6	8.5	14.5	13	1	10	5	10	7	0.025
SAU 40008	M8 X1.25	57	20	4	28.5	8	12.5	19	17	2	20	7	10	11	0.060
SAU 40010	M10X1.25	71	20	5	35	14	22	32	30	2	20	12	10	19	0.220
SAU 40011	M10X1.5	71	20	5	35	14	22	32	30	2	20	12	10	19	0.220
SAU 40012	M12X1.25	75	24	5	35	14	22	32	30	2	20	12	10	19	0.230
SAU 40013	M12X1.75	75	24	5	35	14	22	32	30	2	20	12	10	19	0.230
SAU 40016	M16X1.5	103	32	8	54	22	32	45	41	2	32	20	10	30	0.660
SAU 40020	M20X1.5	119	40	8	54	22	32	45	41	2	40	20	10	30	0.700

DISPONIBILITA' E PREZZO A RICHIESTA  
AVAILABILITY AND PRICE UPON REQUEST

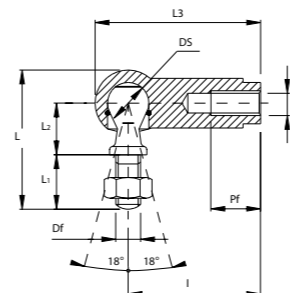

## SA...

SNODI ANGOLARI DIN 71802  
PER CILINDRI PNEUMATICI  
MATERIALE: AVP  
ANGULAR JOINTS DIN 71802  
FOR PNEUMATIC CYLINDERS  
MATERIAL: AVP

SIGLA ARTICLE	Df	P	L1	L2	L	L3	I	D5	CHIAVE KEY	PESO IN Kg. WEIGHT Kg.
SA 10480	M5 X0.8	12	12.5	11	31	32	24.5	10	8	0.020
SA 10481	M6 X1	12	12.5	11	31	32	24.5	10	8	0.020
SA 10482	M8 X1.25	14	16.5	13	40	39	29.5	13	11	0.050
SA 10483	M10X1.5	18	20	17	49	46	34	16	13	0.090
SA 10484	M14X1.5	22	28	23	66	60	45	18	17	0.210

DISPONIBILITA' E PREZZO A RICHIESTA  
AVAILABILITY AND PRICE UPON REQUEST

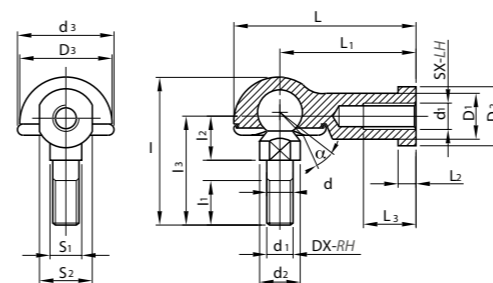

## SA...

SNODI ANGOLARI  
PER CILINDRI PNEUMATICI  
MATERIALE: ALLUMINIO  
ANGULAR JOINTS  
FOR PNEUMATIC CYLINDERS  
MATERIAL: ALUMINIUM

SIGLA ARTICLE	d	d1	d2	d3	I	I1	I2	I3	S1	L	L1	L2	L3	D1	D2	D3	S2	CARGO STATIC LOAD STATIC KN	α GRADI RATES	PESO IN Kg. WEIGHT Kg.
			MAX	MAX	MAX	MIN	MAX	MAX	MAX	MAX	MIN	MAX	MAX	MAX						
SA 20005	5	M5	9	19	29	8	10	21	7	35	27	4	14	9	11	16	9	2.2	25	0.028
SA 20006	6	M6	10	20	35.5	11	11	26	8	40	30	5	14	10	13	19	11	3.5	25	0.039
SA 20008	8	M8	12	24	42.5	12	14	31	10	48	36	5	17	12.5	16	23	14	6.6	25	0.068
SA 20010	10	M10X1.25	14	30	50.5	15	17	37	11	57	43	6.5	21	15	19	27	17	10	25	0.112
SA 20012	12	M12X1.25	17	32	57.5	17	19	42	15	66	50	6.5	25	17.5	22	31	19	16	25	0.164
SA 20014	14	M14X1.5	19	38	73.5	22	21.5	56	17	75	57	8	26	20	25	35	22	19	25	0.254
SA 20016	16	M16X1.5	22	44	79.5	23	23.5	60	19	84	64	8	32	22	27	39	22	26	20	0.336

DISPONIBILITA' E PREZZO A RICHIESTA  
AVAILABILITY AND PRICE UPON REQUEST

# TERMINALI SPECIALI SPECIAL ROD ENDS



*On request Rod Ends with oil intake are available washed and protected by polyethylene-bags LDP-VCI 2000 ( Vapour Corrosion Inhibitor)*  
**Terminali con entrata olio fornibili a richiesta lavati e protetti da buste di polietilene LDP-VCI 2000 (Vapour Corrosion Inhibitor)**

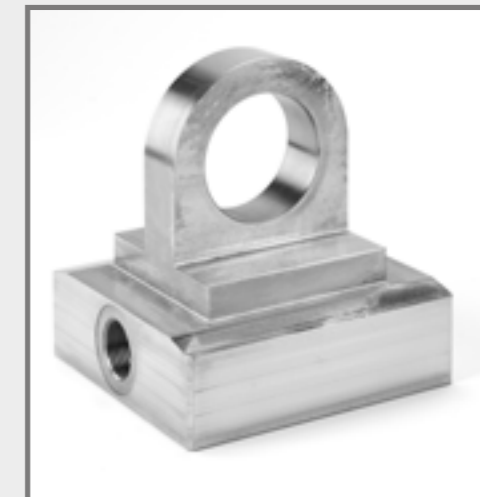
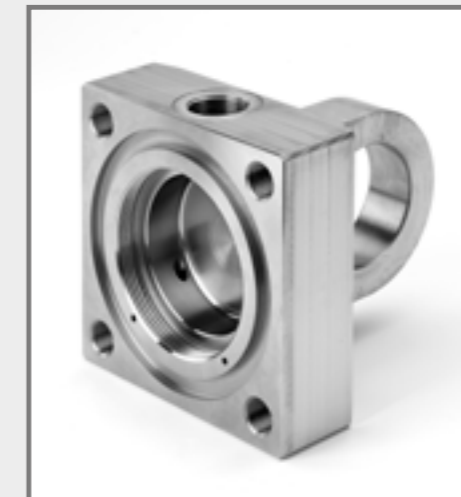
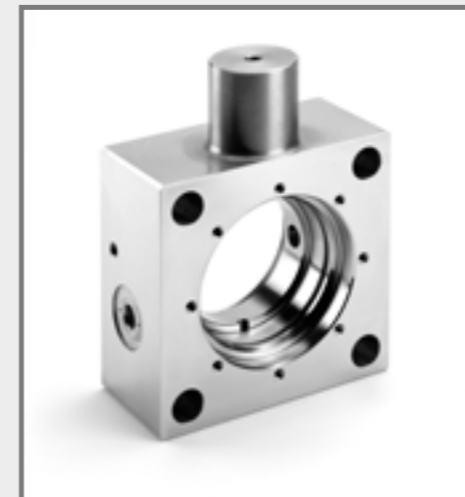
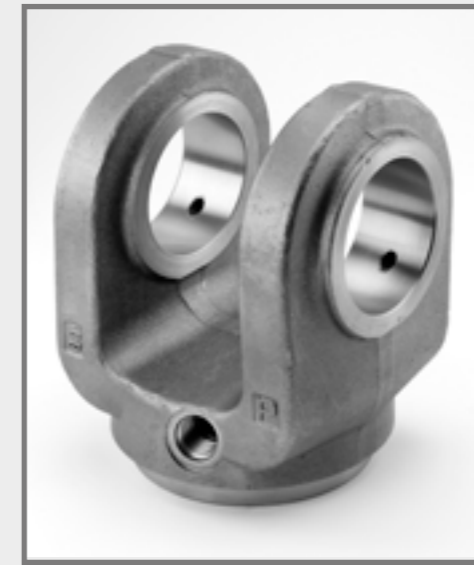

*Gli articoli speciali presenti a catalogo sono stati costruiti in esclusiva per il committente  
 The special parts in this catalogue are exclusively made to the specific customer's requirements*



**SPECIAL COMPONENTS FOR AGRICULTURE**  
**COMPONENTI AGRICOLI SPECIALI**



TABELLA APPLICAZIONI BRACCI 3° PUNTO TABLE FOR FITTING ON TRACTOR	2
BRACCI 3° PUNTO, TIRANTI, MANICOTTI TOP LINKS, END ASSEMBLIES, TUBES	3-7
GANCI, ROTULE, CONI GUIDA HOOKS, BALLS, GUIDANCE CONES	8-13
TERMINALI A SNODO SFERICO BALL JOINT TERMINALS	14-20
ATTACCHI SNODATI PER 3° PUNTO ARTICULATED YOKE FOR 3° POINT LIKAGE	21
STABILIZZATORI RIGIDI RIGID STABILISERS	22-23
BRACCI DI SOLLEVAMENTO LATERALI ADJUSTABLE LEVELLING ARM	24-26
BARRE DI TRAINO DRAWBARS	27
CATENE, MANICOTTI, TIRANTI, GRILLI, PERNI AD OCCHIO CHAINS, ADJUSTERS FOR STABILISERS, SHACKLE WITH PIN, EYEBOLT	29-32
PERNI, SPINOTTI PINS	33-39
SPINE A SCATTO, COPIGLIE LINCH PINS, CLIPS	40-41
BASI OSCILLANTI SWINGING END	42

**GARANZIA.** La garanzia della PAVARINI COMPONENTS S.p.A. per i vizi ed i difetti di qualsiasi natura ed entità ha la durata di un anno dalla data di consegna della merce, è limitata esclusivamente alla riparazione o alla sostituzione gratuita dei pezzi riconosciuti dalla PAVARINI COMPONENTS S.p.A. come difettosi, per difetti di materiale o deficienza di lavorazione. Il destinatario della merce deve denunciare i vizi ed i difetti apparenti entro otto giorni dal ricevimento dei beni e quelli occulti entro otto giorni dalla loro scoperta sotto pena di decadenza della garanzia. La merce contestata dovrà essere rispedita, franca di ogni spesa, alla Sede della PAVARINI COMPONENTS S.p.A. unitamente ad documento di accompagnamento riportante la qualità e la quantità della merce stessa, gli estremi della fattura originaria, ed i motivi della restituzione. La garanzia della PAVARINI COMPONENTS S.p.A. decade se i pezzi resi come difettosi sono stati comunque manomessi o riparati, e qualora i componenti non siano stati utilizzati o impiegati nel rispetto dei dati tecnici riportati nel catalogo tecnico della PAVARINI COMPONENTS S.p.A.

Il reclamo non potrà mai dare luogo all'annullamento e/o alla riduzione delle ordinazioni da parte del committente, e tanto meno, alla corresponsione di indennizzi o risarcimenti di sorta da parte della PAVARINI COMPONENTS S.p.A..

La PAVARINI COMPONENTS S.p.A. non assume alcuna responsabilità per i danni derivati da accidenti di qualsiasi natura che si verificassero durante l'impiego dei suoi prodotti, siano questi dalla PAVARINI COMPONENTS S.p.A. riconosciuti difettosi o meno ad ancor quando la PAVARINI COMPONENTS S.p.A. ne avesse progettato l'applicazione.

**WARRANTY.** The warranty of PAVARINI COMPONENTS S.p.A. for defects and faults of any nature and entity has a duration of one year from the date of delivery of the goods and is exclusively limited to the repair or replacement—free of charge—of parts which are acknowledged as defective by PAVARINI COMPONENTS S.p.A. due to defects in materials or manufacturing. The recipient of the goods must report the defects and faults within eight days from the date of receipt of the goods under penalty of voidance of the guarantee.

The disputed goods must be returned, free from any accessory charges, to the registered offices of PAVARINI COMPONENTS in conjunction with the delivery note specifying the quality and quantity of the goods themselves as well as the details of the invoice and the reasons for the return. The guarantee of PAVARINI COMPONENTS S.p.A. ceases to be effective if the returned pieces were tampered with or repaired or if the components were not utilized in compliance with the specifications stated in the technical catalogue of PAVARINI COMPONENTS S.p.A. The complaint may never result in the cancellation and/or reduction of the orders of the customer nor may result in compensation or indemnities of any type for PAVARINI COMPONENTS S.p.A.

PAVARINI COMPONENTS S.p.A. is not liable for any damages derived from the accidents of any nature which occur during the usage of its products, regardless of whether these products were acknowledged as defective or not by PAVARINI COMPONENTS S.p.A. after their application was designed.

Abbiamo controllato con attenzione ogni dettaglio del presente catalogo. Non ci assumiamo pertanto responsabilità per eventuali indicazioni incomplete od errate. Ci riserviamo per le modifiche che risultano dal continuo sviluppo dei nostri prodotti. Although every effort has been made to ensure the accuracy of the information given in this catalogue, no liability can be accepted for any omissions or errors. We reserve the right to make alteration arising from the continuous development of our products.

ART.	MARCA E MODELLO / BRAND & MODEL
<b>3P10005</b>	PER MACCHINE SPECIALI / FOR SPECIAL MACHINES
<b>3P10010</b>	SAME SAMETTO+VIGNETO GOLDONI GM4 VALPADANA 412 FERRARI PG8,TR36 +TRATTORINO BERTOLINI 433 NRS
<b>3P10020</b>	SAME SAMETTO, SAMETTO VIGNETO
<b>3P10030</b>	FIAT 300 AGRIFULL JOLLY 50,68 SC GOLDONI TRATTORINI / MINI TRACTORS PASQUALI TRATTORINI / MINI TRACTORS LANDINI R 3000, R3200 NIBBI TONSON TOSELLI 45HP
<b>3P10040</b>	LANDINI C4000, CS4000, C3500 AGRIFULL JOLLY 50
<b>3P10050</b>	FIAT 211 PICCOLA / SMALLER LANDINI C3500, C4000, CS4000 SAME 240, MINUTAURO SIRENETTA 2 RMDT PULEDRO TRENTO , ITALIA DT FRUTT.
<b>3P10060</b>	AGRIFULL C50 FIAT 455C - 355C SAME ITALIA, PULEDRO, ATLANTA
<b>3P10065</b>	PER MACCHINE SPECIALI / FOR SPECIAL MACHINES
<b>3P10070</b>	SAME FALCON, FALCON RISAIA, MINITAURO 55 FALCON C LAMBORGHINI C352, C352S, 1C, 4C, 5C AGRIFULL 230C, 235C
<b>3P10080</b>	LAMBORGHINI 10, 10TL, 5C, 1RDT, 2RDT, 4C, 5CTL 1RTF, 1RDTS, 2RDTS
<b>3P10085</b>	AGRIFULL 345C, 355C, C60, C70 FIAT 420, 420DT, 450/8, 450/8DT, 450, 480 480DT, 500S, 500SDT , 540S 540SDT, 480/8, 480/8DT, 505C, 605C MF 165, 168, 148, 702
<b>3P10090</b>	FIAT 355C, 455C, 505C, 605C, 420+TD 450 450/8+TD, 480/+TD, 480/8+TD, 500S+TD 540S+TD, 80/76TD AGRIFULL C50, C60, C70, C345, C355 MF 148,165,168,702
<b>3P10100</b>	FIAT 640, 640DT, 670, 670DT, 550, 550DT
<b>3P10110</b>	FIAT 850 OM 615, 715 LANDINI TL 21, TL 22, R6000, R7000 LAMBORGHINI R704, 204, 7RC
<b>3P10115</b>	PER MACCHINE SPECIALI / FOR SPECIAL MACHINES
<b>3P10120</b>	SAME LEONE, ARIETE, SATURNO LANDINI 80F, 6560L, 8560F CARRARO 455, 552, 554, 602, 704 ITMA A553, 600, 654, 700
<b>3P10130</b>	DEUTZ D6808, D7206, MF 165, 168, 85, 240, 254, 255, 274 FIAT 570, 570DT, 580, 580DT OM 650, 750S DIAMANTE JOHN DEERE 1140, 1640, 2040 LANDINI 5500 2RM, 5000 DT 6500 2RM, MARK II,6500DT MARK II, 6505 F, 6550 2RM, 6550 DT

ART.	MARCA E MODELLO / BRAND & MODEL
<b>3P10135</b>	HURLIMANN H4904RM SAME SATURNO 80S, CENTURION, LEONE 70, LEONE 75, ARIETE 85, LEOPARD 85,PANTER 90
<b>3P10140</b>	AGRIFULL TORNADO 80, 85 TURBO, RODEO 90 TURBO, RODEO 95 TURBO FIAT 850S, 850SDT, 1000S, 1000SDT, 670F, 670FDT FORDSON MAJOR- LANDINI R6000, R7000 OM 615
<b>3P10150</b>	FIAT 670H , 680, 780, 880, 980, 8088, 70/90 100/90+DT LANDINI 8000, 9880,10000,12500,14500 MF 290, 575, 590, 595, 2620, 2640, 2680 SAME DRAGO, BUFFALO, TIGER, ROW CROP LAMBORGHINI R654, R1056, R1256 HURLIMANN H6130 CARRARO 552, 554,652,702,704,732,734,842,884 78/2,78/4,88/2,88/4,98/2,98/14 751, 781,851,891,951,981, 1151, 1181, 1451
<b>3P10160</b>	CARRARO 552, 554,652,654,702,704,732,734,842, 844, 78.2, 78.4, 88.2, 88.4, 98.2, 98.4 HURLIMANN H6130 4RM MF 290DT, 575, 590, 590DT,595MK II LANDINI R8000, R8000DT SAME DRAGO 120, BUFFALO 130
<b>3P10170</b>	CARRARO 78/2, 78/4, 88/2, 88/4, 98/2, 98/4 LANDINI R8000, R8000DT MASSEY FERGUSON 290, 575, 590, 595 SAME DRAGO
<b>3P10180</b>	FIAT 1000 SAME ROW CROP LANDINI LDTL29 - 11 ITALIA MASSEY FERGUSON
<b>3P10190</b>	PER MACCHINE SPECIALI / FOR SPECIAL MACHINES
<b>3P10200</b>	TRATTORI VARI OLTRE 90HP / TRACTORS OVER 90HP SAME PANTER, TIGER, DRAGO, BUFFALO FIAT 980,1000, 1180, 90/90, 100/90 AGRIFULL RODEO 90 TURBO, RODEO 95 TURBO LAMBORGHINI R904, R955, 1056
<b>3P10205</b>	TRATTORI VARI OLTRE 90HP / TRACTORS OVER 90HP
<b>3P10210</b>	TRATTORI OLTRE 90HP / TRACTORS OVER 90HP LANDINI 9500, 12500, 14500 MF 1114,1134 RENAULT 891,951,981,1181,1451,1065P,TX113
<b>3P10215</b>	SAME HERCULES 160 HURLIMANN H6160 4RM
<b>3P10220</b>	TRATTORI VARI OLTRE 115HP / TRACTORS OVER 115HP FIAT 1300,1380,1580,1880, 115/90DT, 130/90DT, 140/90DT, 160/90DT, 180/90DT FENDT 612LS, 614LS, 615LS, 626LSA SAME LASER 130,150, GALAXY 170,TRIDENT, HERCULES
<b>3P10225</b>	LAMBORGHINI 1306,1506, 1706 MF 2620, 2640, 2670, 2680 FORD TW15, 25, 35, ZETOR 12145, 16145 RENAULT 1181, 1451, TX133, TX145
<b>3P10226</b>	FIAT 1300
<b>3P10227</b>	FIAT 1300
<b>3P10229</b>	JOHN DEERE

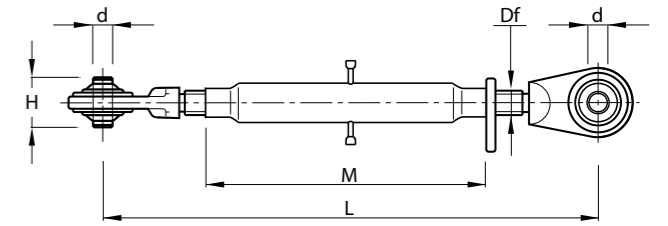

SIGLA ARTICLE	CAT.	d (A12)	H (h11)	Df	M	L		TIRANTE FILETTATO THREADED ROD		PESO Kg.
						MIN.	MAX.	DX	SX	
<b>3P 10005</b>	1	19	44	M22X2.5	150	260	350	TF 10300 DX - TF 10310 SX	1.70	
<b>3P 10010</b>	1	19	44	M22X2.5	230	345	490	TF 10300 DX - TF 10310 SX	2.40	
<b>3P 10020</b>	1	19	44	M22X2.5	280	390	540	TF 10300 DX - TF 10310 SX	2.62	
<b>3P 10030</b>	1	19	44	M22X2.5	300	410	560	TF 10300 DX - TF 10310 SX	2.84	
<b>3P 10040</b>	1	19	44	M24X2.5	320	430	570	TF 10320 DX - TF 10330 SX	2.96	
<b>3P 10050</b>	1	19	44	M24X2.5	370	480	620	TF 10320 DX - TF 10330 SX	3.04	
<b>3P 10060</b>	1	19	44	M24X2.5	470	580	720	TF 10320 DX - TF 10330 SX	3.48	
<b>3P 10065</b>	1	19	44	M27X3	220	330	450	TF 10340 DX - TF 10350 SX	3.00	
<b>3P 10070</b>	1	19	44	M27X3	320	430	630	TF 10340 DX - TF 10350 SX	3.56	
<b>3P 10080</b>	1	19	44	M27X3	370	480	680	TF 10340 DX - TF 10350 SX	3.76	
<b>3P 10083</b>	1	19	44	M27X3	400	510	710	TF 10340 DX - TF 10350 SX	3.88	
<b>3P 10085</b>	1	19	44	M27X3	430	540	740	TF 10340 DX - TF 10350 SX	3.98	
<b>3P 10090</b>	1	19	44	M27X3	470	580	780	TF 10340 DX - TF 10350 SX	4.18	
<b>3P 10100</b>	1	19	44	M27X3	570	680	880	TF 10340 DX - TF 10350 SX	4.62	
<b>3P 10110</b>	1/2	19/25.4	44/51	M27X3	470	585	800	TF 10340 DX - TF 10390 SX	4.54	
<b>3P 10115</b>	2	25.4	51	M27X3	220	340	460	TF 10380 DX - TF 10390 SX	3.54	
<b>3P 10120</b>	2	25.4	51	M27X3	320	460	680	TF 10380 DX - TF 10390 SX	4.24	
<b>3P 10125</b>	2	25.4	51	M27X3	400	520	740	TF 10380 DX - TF 10390 SX	4.60	
<b>3P 10130</b>	2	25.4	51	M27X3	430	550	770	TF 10380 DX - TF 10390 SX	4.70	
<b>3P 10132</b>	2	25.4	51	M27X3	500	620	840	TF 10380 DX - TF 10390 SX	5.04	
<b>3P 10135</b>	2	25.4	51	M30X3	360	480	710	TF 10400 DX - TF 10410 SX	4.86	
<b>3P 10138</b>	2	25.4	51	M30X3	400	520	750	TF 10400 DX - TF 10410 SX	5.02	
<b>3P 10140</b>	2	25.4	51	M30X3	430	550	780	TF 10400 DX - TF 10410 SX	5.14	
<b>3P 10150</b>	2	25.4	51	M30X3	470	590	820	TF 10400 DX - TF 10410 SX	5.32	
<b>3P 10155</b>	2	25.4	51	M30X3	500	620	850	TF 10400 DX - TF 10410 SX	5.42	
<b>3P 10160</b>	2	25.4	51	M30X3	530	650	880	TF 10400 DX - TF 10410 SX	5.56	
<b>3P 10170</b>	2	25.4	51	M30X3	560	680	910	TF 10400 DX - TF 10410 SX	5.66	
<b>3P 10180</b>	2	25.4	51	M30X3	610	730	960	TF 10400 DX - TF 10410 SX	5.82	
<b>3P 10190</b>	2	25.4	51	M30X3	730	850	1080	TF 10400 DX - TF 10410 SX	6.38	
<b>3P 10200</b>	2	25.4	51	M36X3	400	525	740	TF 10420 DX - TF 10430 SX	6.82	
<b>3P 10203</b>	2	25.4	51	M36X3	460	585	800	TF 10420 DX - TF 10430 SX	7.28	
<b>3P 10205</b>	2	25.4	51	M36X3	520	645	860	TF 10420 DX - TF 10430 SX	7.62	
<b>3P 10210</b>	2	25.4	51	M36X3	570	695	910	TF 10420 DX - TF 10430 SX	8.14	
<b>3P 10215</b>	2	25.4	51	M36X3	400	555	840	TF 10440 DX - TF 10450 SX	9.42	
<b>3P 10220</b>	2/3	25.4/32	51/51	M36X3	400	555	840	TF 10440 DX - TF 10470 SX	9.32	
<b>3P 10225</b>	3	32	51	M36X3	460	615	900	TF 10460 DX - TF 10470 SX	9.68	
<b>3P 10226</b>	2	25.4	51	M40X3	500	635	860	TF 10475 DX - TF 10476 SX	9.10	
<b>3P 10227</b>	2	25.4	51	M40X3	620	755	980	TF 10475 DX - TF 10476 SX	9.84	

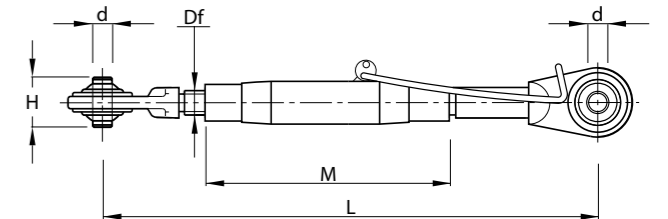

SIGLA ARTICLE	CAT.	d	H (h11)	Df	M	L		IMPIEGO APPLICATION	PESO IN Kg. WEIGHT Kg.
						MIN.	MAX.		
<b>3P 10229</b>	1/2	20.2/25.4	44/51	UNC 1" 1/8 7G	318	545	790	JOHN DEERE	5.14



TIRANTE FILETTATO CON ROTULA SFERICA  
 ACCOPPIAMENTO ACCIAIO SU ACCIAIO - CORPO IN ACCIAIO C 40 UNI EN 10083-1

END ASSEMBLIES  
 COUPLING STEEL ON STEEL - ROD END OF STEEL C 40 UNI EN 10083-1

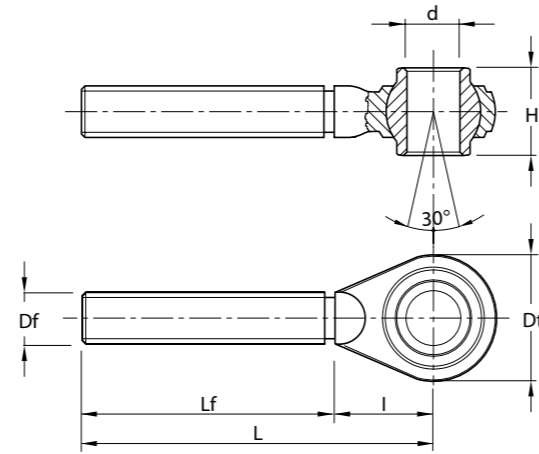

SIGLA ARTICLE	CAT.	d (A12)	H (h11)	Df	L	Lf	I	Dt	PESO IN Kg. WEIGHT Kg.
TF 10300 DX	1	19	44	M22X2.5	165	115	50	58	0.71
TF 10310 SX	1	19	44	M22X2.5	165	115	50	58	0.71
TF 10320 DX	1	19	44	M24X2.5	165	115	50	58	0.82
TF 10330 SX	1	19	44	M24X2.5	165	115	50	58	0.82
TF 10321 DX	1	19	44	M24X2.5	165	115	50	62	0.85
TF 10322 SX	1	19	44	M24X2.5	165	115	50	62	0.85
TF 10333 DX	1	19	44	M24X3	165	115	50	62	0.86
TF 10334 SX	1	19	44	M24X3	165	115	50	62	0.86
TF 10338 DX	1	19	44	M24X3	205	155	50	62	0.98
TF 10339 SX	1	19	44	M24X3	205	155	50	62	0.98
TF 10335 DX	2	25.4	51	M24X3	220	165	55	75	1.32
TF 10336 SX	2	25.4	51	M24X3	220	165	55	75	1.32
TF 10340 DX	1	19	44	M27X3	205	155	50	58	1.08
TF 10350 SX	1	19	44	M27X3	205	155	50	58	1.08
TF 10345 DX	1	19	44	M27X3	205	155	50	62	1.12
TF 10346 SX	1	19	44	M27X3	205	155	50	62	1.12
TF 10380 DX	2	25.4	51	M27X3	220	165	55	75	1.44
TF 10390 SX	2	25.4	51	M27X3	220	165	55	75	1.44
TF 10355 DX	1	19	44	M30X3	225	175	50	62	1.36
TF 10356 SX	1	19	44	M30X3	225	175	50	62	1.36
TF 10400 DX	2	25.4	51	M30X3	220	165	55	75	1.62
TF 10410 SX	2	25.4	51	M30X3	220	165	55	75	1.62
TF 10358 DX	1	19	44	M30X3.5	225	175	50	62	1.34
TF 10359 SX	1	19	44	M30X3.5	225	175	50	62	1.34
TF 10415 DX	2	25.4	51	M30X3.5	220	165	55	75	1.60
TF 10416 SX	2	25.4	51	M30X3.5	220	165	55	75	1.60
TF 10420 DX	2	25.4	51	M36X3	220	165	55	80	2.14
TF 10430 SX	2	25.4	51	M36X3	220	165	55	80	2.14
TF 10440 DX	2	25.4	51	M36X3	270	200	70	96	3.44
TF 10450 SX	2	25.4	51	M36X3	270	200	70	96	3.44
TF 10460 DX	3	32	51	M36X3	270	200	70	96	3.34
TF10470 SX	3	32	51	M36X3	270	200	70	96	3.34
TF 10475 DX	2	25.4	51	M40X3	230	170	60	80	2.74
TF 10476 SX	2	25.4	51	M40X3	230	170	60	80	2.74

TIRANTE A GAMBO ROTONDO GREZZO CON ROTULA SFERICA  
 ACCOPPIAMENTO ACCIAIO SU ACCIAIO - CORPO IN ACCIAIO C 40 UNI EN 10083-1

BALL JOINT TERMINAL WITH ROUND STEM  
 COUPLING STEEL ON STEEL - ROD END OF STEEL C 40 UNI EN 10083-1

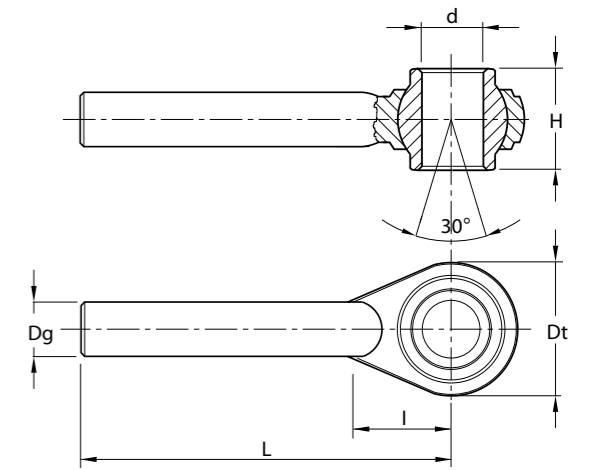

SIGLA ARTICLE	CAT.	d (A12)	H (h11)	Dg (Ø)	L	I	Dt	PESO IN Kg. WEIGHT Kg.
TGG 10305	1	19	44	20	165	50	58	0.71
TGG 10312	1	19	44	22	165	50	58	0.82
TGG 10325	1	19	44	25	165	50	62	0.98
TGG 10342	1	19	44	25	205	50	58	1.14
TGG 10341	1	19	44	27	205	50	62	1.38
TGG 10343	1	19	44	29	225	50	62	1.50
TGG 10394	2	25.4	51	28	220	55	75	1.64
TGG 10395	2	25.4	51	30	220	55	75	1.76
TGG 10425	2	25.4	51	36	220	55	80	2.32
TGG 10445	2	25.4	51	37	270	75	96	3.80
TGG 10455	3	32	51	37	270	75	96	3.70
TGG 10474	2	25.4	51	43	230	60	80	3.20

MANICOTTI PER 3 PUNTO  
 3 rd POINT TUBE

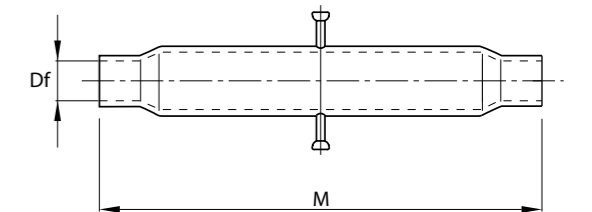

SIGLA ARTICLE	M	Df	PESO IN Kg. WEIGHT Kg.
M3P 010	230	M22X2,5	0.90
M3P 020	280	M22X2,5	1.10
M3P 030	300	M22X2,5	1.32
M3P 040	320	M24X2,5	1.22
M3P 050	370	M24X2,5	1.30
M3P 060	470	M24X2,5	1.74
M3P 065	220	M27X3	0.92
M3P 070	320	M27X3	1.26
M3P 080	370	M27X3	1.50
M3P 083	400	M27X3	1.60
M3P 085	430	M27X3	1.68
M3P 090	470	M27X3	1.90
M3P 132	500	M27X3	2.02
M3P 100	570	M27X3	2.36

SIGLA ARTICLE	M	Df	PESO IN Kg. WEIGHT Kg.
M3P 135	360	M30X3	1.54
M3P 138	400	M30X3	1.70
M3P 140	430	M30X3	1.82
M3P 150	470	M30X3	2.00
M3P 155	500	M30X3	2.10
M3P 160	530	M30X3	2.24
M3P 170	560	M30X3	2.34
M3P 180	610	M30X3	2.50
M3P 190	730	M30X3	3.06
M3P 200	400	M36X3	2.28
M3P 225	460	M36X3	2.74
M3P 205	520	M36X3	3.08
M3P 210	570	M36X3	3.60
M3P 226	500	M40X3	3.28
M3P 227	620	M40X3	4.02

BRACCIO 3° PUNTO CON GANCIO RAPIDO COMPLETO DI CORDA E ROTULA SFERICA  
TOP LINK WITH HOOK "RAPID", END ASSEMBLIES AND CHAIN

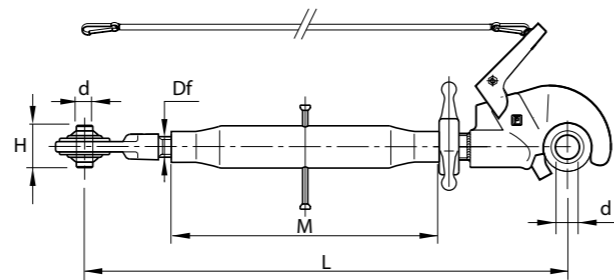

SIGLA ARTICLE	CAT.	d (A12)	H (h11)	Df	M	L		TIRANTE FILET. SX THREADED ROD LHS	GANCIO "RAPID" DX HOOK "RAPID" RHS	PESO IN Kg. WEIGHT Kg.
						MIN.	MAX.			
3PR 10070	2	25.4	51	M27X3	320	530	740	TF 10390 SX	GR 10980	6.24
3PR 10080	2	25.4	51	M27X3	370	560	790	TF 10390 SX	GR 10980	6.48
3PR 10085	2	25.4	51	M27X3	430	610	860	TF 10390 SX	GR 10980	6.56
3PR 10090	2	25.4	51	M27X3	470	650	900	TF 10390 SX	GR 10980	6.78
3PR 10100	2	25.4	51	M27X3	570	750	1000	TF 10390 SX	GR 10980	7.24
3PR 10135	2	25.4	51	M30X3	360	550	790	TF 10410 SX	GR 10981	6.90
3PR 10140	2	25.4	51	M30X3	430	610	850	TF 10410 SX	GR 10981	7.18
3PR 10150	2	25.4	51	M30X3	470	650	890	TF 10410 SX	GR 10981	7.36
3PR 10160	2	25.4	51	M30X3	530	710	950	TF 10410 SX	GR 10981	7.60
3PR 10170	2	25.4	51	M30X3	560	740	980	TF 10410 SX	GR 10981	7.70
3PR 10180	2	25.4	51	M30X3	610	790	1030	TF 10410 SX	GR 10981	7.86
3PR 10190	2	25.4	51	M30X3	730	910	1150	TF 10410 SX	GR 10981	8.42
3PR 10200	2	25.4	51	M36X3	400	610	840	TF 10430 SX	GR 10971	8.92
3PR 10224	2	25.4	51	M36X3	460	670	900	TF 10430 SX	GR 10971	9.38
3PR 10205	2	25.4	51	M36X3	520	730	960	TF 10430 SX	GR 10971	9.72
3PR 10210	2	25.4	51	M36X3	570	780	1010	TF 10430 SX	GR 10971	10.24
3PR 10220	3	32	51	M36X3	400	630	900	TF 10470 SX	GR 10972	12.41
3PR 10225	3	32	51	M36X3	460	690	960	TF 10470 SX	GR 10972	12.87
3PR 10206	3	32	51	M36X3	520	750	1020	TF 10470 SX	GR 10972	13.20
3PR 10211	3	32	51	M36X3	570	800	1070	TF 10470 SX	GR 10972	13.72
3PR 10226	2	25.4	51	M40X3	500	710	970	TF 10476 SX	GR 10973	13.20
3PR 10227	2	25.4	51	M40X3	620	830	1090	TF 10476 SX	GR 10973	13.94

BUSSOLE DI RIDUZIONE  
CONVERSION BUSHES

SIGLA ARTICLE	CAT.	D	d	L	IMPIEGO APPLICATION	PESO IN Kg. WEIGHT Kg.
BP 11225	3/2	37	28.4	44	BRACCI SOLLEVAMENTO INFERIORI LOWER LIFTING ARM	0.13
BP 11230	2/1	28.4	22.1	44		0.08
BP 11240	2/1	25.4	19	51	3° PUNTO / TOP LINK	0.08
BP 11245	3/2	32	25.4	51	3° PUNTO / TOP LINK	0.12

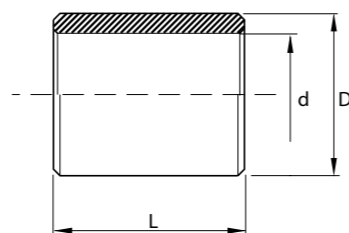

CONTRODADI PER BRACCIO 3° PUNTO  
TOPLINK LOCK NUT

SIGLA ARTICLE		Df	D	R	S	PESO IN Kg. WEIGHT Kg.
CA 22	ALETTA / WING COLLAR	M22X2.5	45	60	6	0.10
CA 24	ALETTA / WING COLLAR	M24X2.5	45	60	6	0.10
CA 23	ALETTA / WING COLLAR	M24X3	45	60	6	0.10
CA 25	ALETTA / WING COLLAR	M27X3	45	60	6	0.09
CA 26	ALETTA / WING COLLAR	M30X3	45	60	6	0.08
CA 38	ALETTA / WING COLLAR	M30X3.5	45	60	6	0.08
CA 27	ALETTA / WING COLLAR	M36X3	60	88	10	0.26
CA 28	ALETTA / WING COLLAR	M40X3	60	88	10	0.24

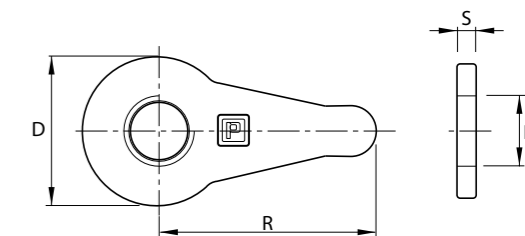

SIGLA ARTICLE	MOD.	Df	D	R	S	PESO IN Kg. WEIGHT Kg.
CS 29	STELLA / STAR COLLAR	M22X2.5	34	30	12	0.06
CS 30	STELLA / STAR COLLAR	M24X2.5	34	30	12	0.06
CS 35	STELLA / STAR COLLAR	M24X3	34	30	12	0.06
CS 31	STELLA / STAR COLLAR	M27X3	40	45	18	0.15
CS 32	STELLA / STAR COLLAR	M30X3	40	45	18	0.14
CS 36	STELLA / STAR COLLAR	M30X3.5	40	45	18	0.14
CS 33	STELLA / STAR COLLAR	M36X3	52	45	18	0.17
CS 34	STELLA / STAR COLLAR	M40X3	52	45	18	0.16

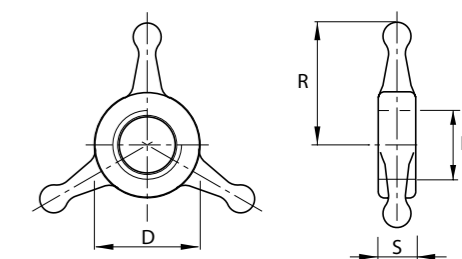

GRUPPO COMPLETO ATTACCO A 3 PUNTI

COMPLETE 3-POINT LINKAGE SET

SIGLA ARTICLE	IMPIEGO APPLICATION
GC 11	FIAT 605 C
GC 12	FIAT 311 - 355 - 411 C - 455 C
GC 13	FIAT 415 - 450 R
GC 14	FIAT 640 R

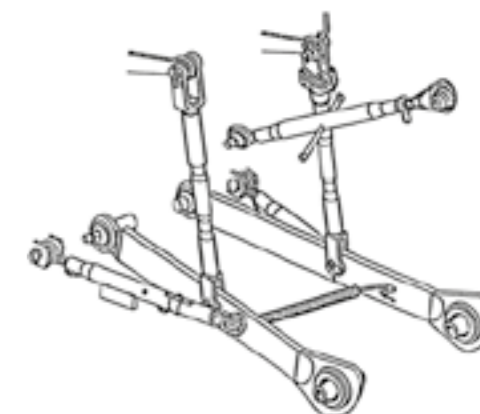

**GANCIO SUPERIORE "RAPID" CON FILETTO**  
*THREADED TOP LINK AUTOMATIC HITCH*

SIGLA ARTICLE	CAT.	D	Df (DX-RHS)	Lf	L	PESO IN Kg. WEIGHT Kg.
GR 10980	2	50	M27X3	180	105	2.74
GR 10981	2	50	M30X3	180	105	2.96
GR 10967	2	50	M30X3.5	180	105	2.96
GR 10971	2	50	M36X3	180	105	3.40
GR 10978	3/2	60	M30X3	180	132	5.36
GR 10968	3/2	60	M30X3.5	180	132	5.36
GR 10972	3/2	60	M36X3	180	132	5.78
GR 10973	3/2	60	M40X3	180	132	6.08

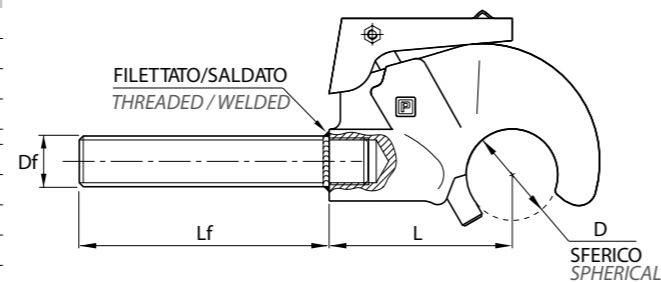

**GANCIO SUPERIORE "RAPID" A SALDARE**  
 - CAT. 2 - 3 PER CILINDRI IDRAULICI  
*WELD ON TOP LINK AUTOMATIC HITCH*

SIGLA ARTICLE	CAT.	D	L	Df (DX-RHS)	Pf	PESO IN Kg. WEIGHT Kg.
GR 10975	2	50	105	FORO/BORE Ø12	15	2.02
GR 10976	2	50	105	M20X1.5	25	1.96
GR 10969	2	50	105	M27X2	25	2.10
*GR 10974	2	50	105	M30X2	25	2.30
GR 10977	3/2	60	132	FORO/BORE Ø20	25	4.50
GR 10979	3/2	60	132	M27X2	45	4.24
** GR 10970	3/2	60	132	M36X2	45	4.04

\* A RICHIESTA M24x2 - \*\* A RICHIESTA M30x2  
 \* ON REQUEST M24x2 - \*\* ON REQUEST M30x2

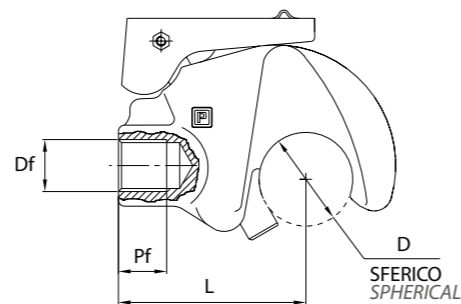

**ROTULE PER GANCIO RAPIDO SUPERIORE**  
*BALLS FOR UPPER AUTOMATIC HITCH*

SIGLA ARTICLE	CAT.	d (A12)	D	H (h11)	PESO IN Kg. WEIGHT Kg.
SF 10989	1	19	50	51	0.42
SF 10985	2	25.4	50	51	0.34
SF 10987	3/2	25.4	60	51	0.64
SF 10988	3	32	60	51	0.54

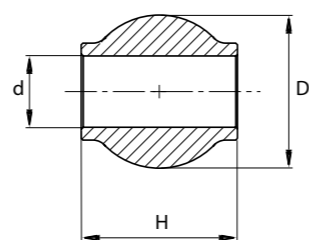

**CORDA DI COMANDO PER GANCIO SUPERIORE E INFERIORE**  
*CONTROL WIRE FOR UPPER AND LOWER AUTOMATIC HITCH*

SIGLA ARTICLE	LUNGHEZZA TOTALE TOTALE LENGTH mm.
CGS 10997	1500 - SUPERIORE / UPPER
CGI 10996	4400 - INFERIORE / LOWER

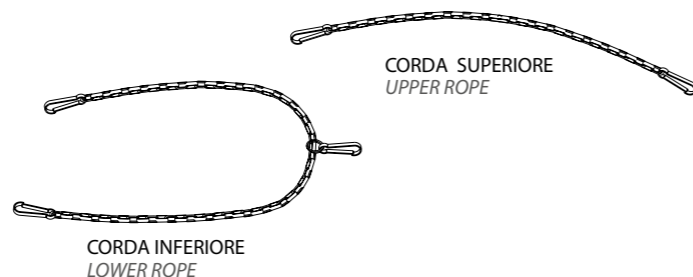

**GANCIO INFERIORE "RAPID"**  
*LOWER HITCH POINT*

SIGLA ARTICLE	ATTACCO HITCH	CAT.	D	INTERNO ROTULA INNER BALL Ø	L	H	PESO IN Kg. WEIGHT Kg.
GID 10982	DX	2	56	28.4	108	80	4.56
GIS 10986	SX	2	56	28.4	108	80	4.56
GID 10983	DX	3	64	37	120	90	6.10
GIS 10984	SX	3	64	37	120 <td 90	6.10	

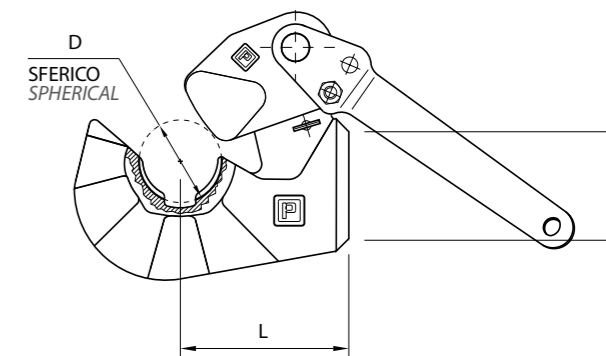

**DISTANZIALE REGOLABILE A MOLLA PER BRACCI INFERIORI**  
*ADJUSTABLE SPACER-SPRING FOR LOWER ARM*

SIGLA ARTICLE	CAT.	LUNGHEZZA LENGTH		TYPE	PESO IN Kg. WEIGHT Kg.
		MIN.	MAX.		
DM 10965	2	500	720	A	1.90
DM 10966	3	600	900	B	2.38

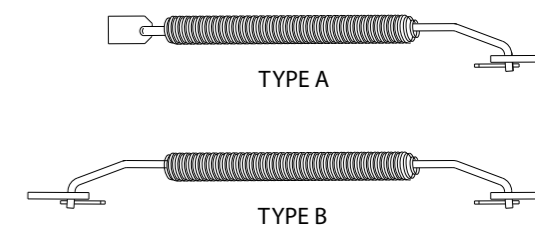

**CONI GUIDA CON ROTULA E SPINA A SCATTO**  
*GUIDANCE CONES WITH BALLS AND TRIP SPIN PIN*

SIGLA ARTICLE	CAT.	d (A12)	D	PESO IN Kg. WEIGHT Kg.
CR 10990	2	28.4	56	0.92
CR 10991	3/2	28.4	64	1.18
CR 10992	3	37	64	0.96

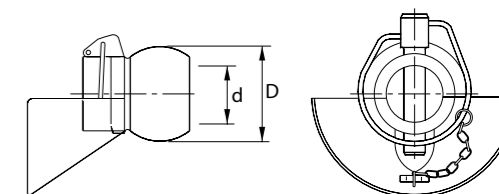

**DISTANZIALI PER ROTULE SENZA CONO**  
*SPACING FOR BALLS WITHOUT CONES*

SIGLA ARTICLE	CAT.	d (A12)	D	S	PESO IN Kg. WEIGHT Kg.
SS 10955	2	28.4	56	7	0.10
SS 10956	3/2	28.4	64	7	0.13
SS 10957	3	37	64	7	0.10

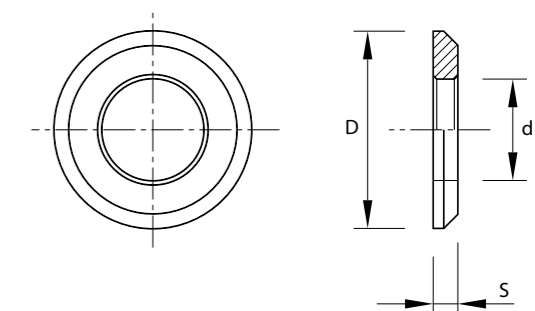

**ROTULE SENZA CONI GUIDA PER GANCIO INFERIORE "RAPID"**  
*BALLS WITHOUT GUIDANCE CONES FOR LOWER HITCH POINT*

SIGLA ARTICLE	CAT.	d (A12)	D	H (h11)	PESO IN Kg. WEIGHT Kg.
SF 10999	2/1	22.1	56	45	0.80
SF 10993	2	28.4	56	45	0.44
SF 10994	3/2	28.4	64	45	0.72
SF 10998	3	37	64	45	0.56
SF 10995	-	38	64	45	0.56

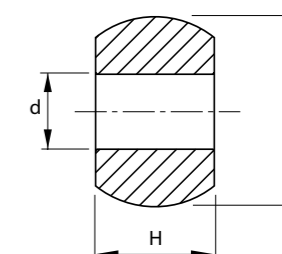

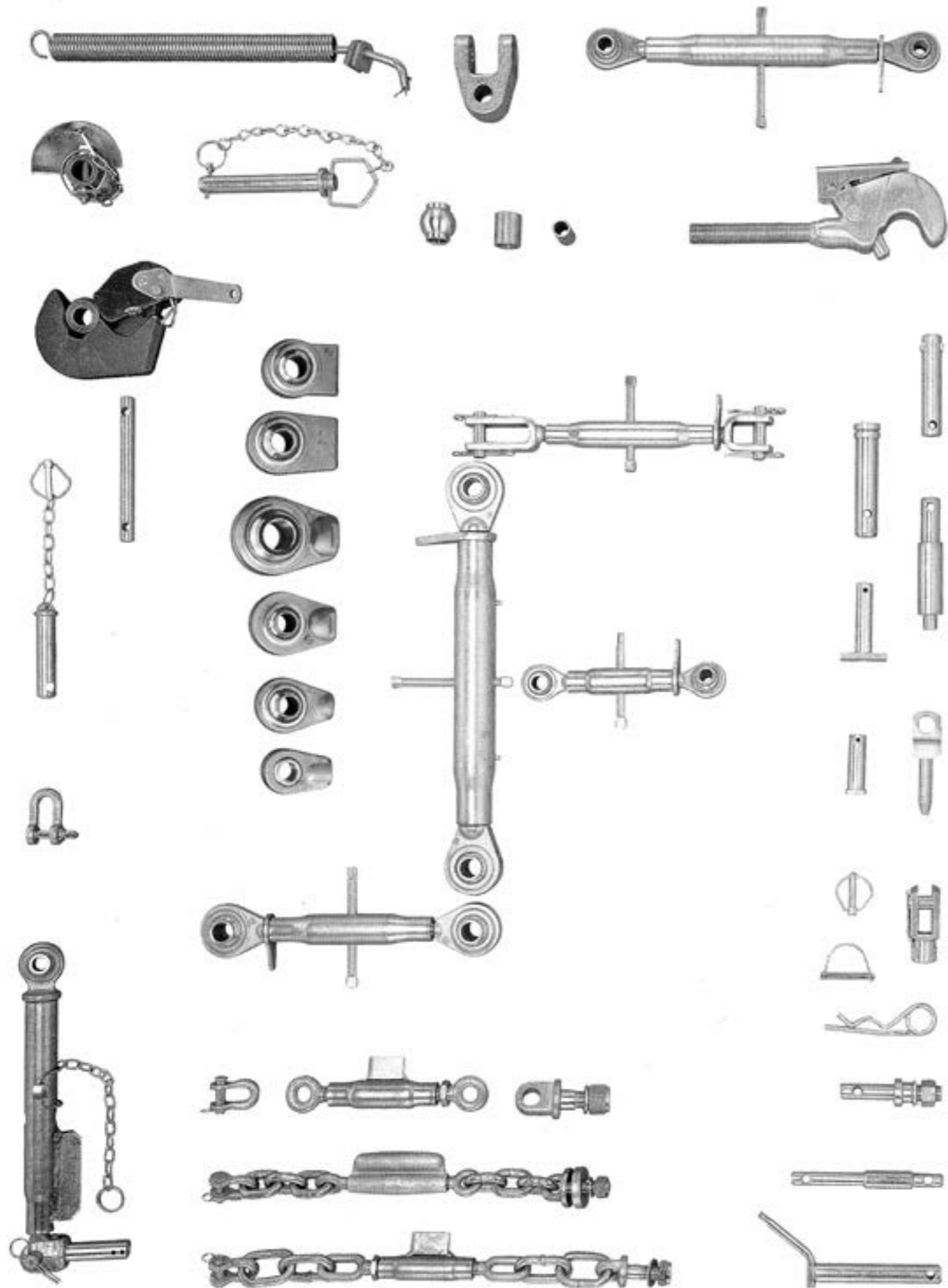

GANCI AUTOMATICI PER BRACCI INFERIORI DI ATTACCHI A TRE PUNTI  
 AUTOMATIC TOP LINK HOOKS FOR LOWER SIDES

GANCIO AUTOMATICO CAT. 2 S  
 AUTOMATIC TOP LINK CAT. 2 S

SIGLA ARTICLE
GI - 2S

GANCIO AUTOMATICO CAT. 2  
 SEDE ROTULA TEMPRATA AD ALTA FREQUENZA  
 AUTOMATIC TOP LINK HOOKS POSITION OF THE  
 HARDENED BALL AT HIGH FREQUENCY

SIGLA ARTICLE
GI - 2

GANCIO AUTOMATICO CAT. 3  
 SEDE ROTULA TEMPRATA AD ALTA FREQUENZA  
 AUTOMATIC TOP LINK HOOKS POSITION OF THE  
 HARDENED BALL AT HIGH FREQUENCY

SIGLA ARTICLE
GI - 3

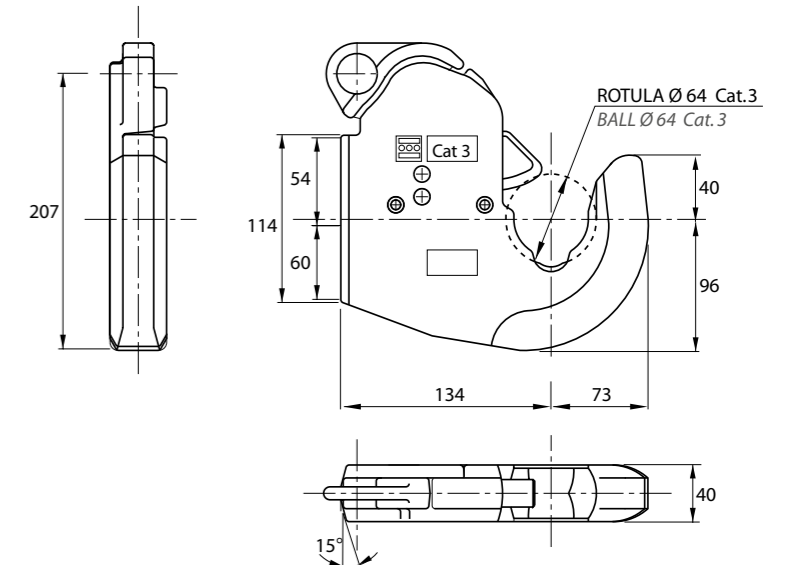
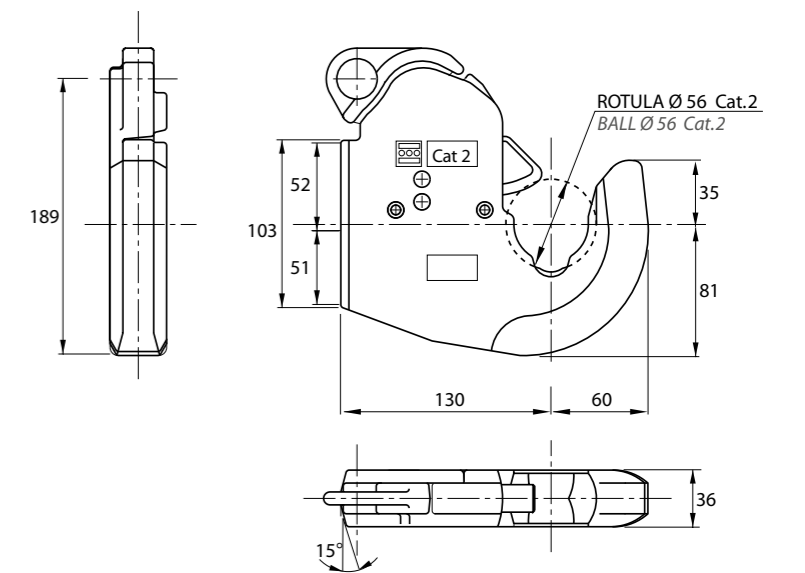
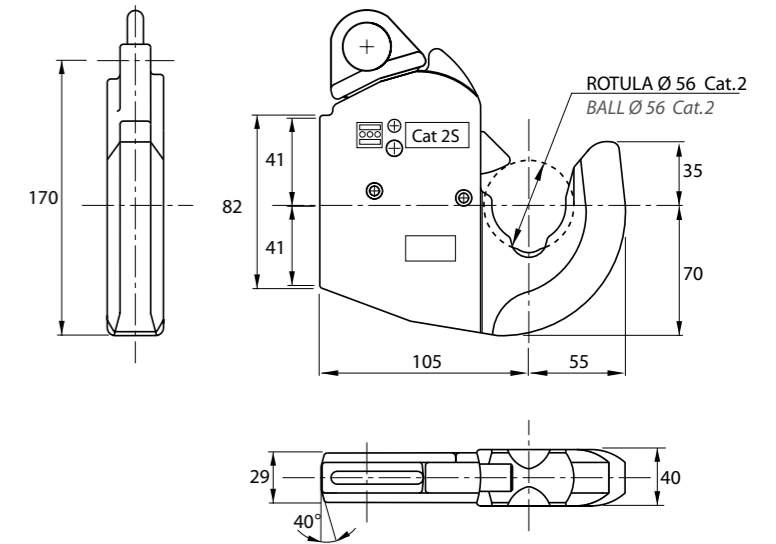

**KIT DI AGGANCIAMENTO RAPIDO PER TRATTORI**  
**QUICK COUPLING SET**

**COMPOSIZIONE DEI KIT**  
**KIT COMPOSITION**

**KIT CATEGORIA 2**  
**KIT CATEGORY 2**

POS.	DESCRIZIONE DESCRIPTION	N.
1	GANCI INFERIORI " RAPID " DX E SX / LOWER HITCH "RAPID" RHS +LHS	1+1
2	GANCIO SUPERIORE " RAPID " FILETTATURA M27X3-M30X3-M36X3 UPPER HITCH "RAPID" THREAD - M27X3-M30X3-M36X3	1
3	DISTANZIALE REGOLABILE / ADJUSTABLE DISTANCE PIECE	1
4	CORDA COMANDO GANCI INFER. / LOWER HITCH CONTROL ROPE	1
5	CORDA COMANDO GANCI SUPER. / UPPER HITCH CONTROL ROPE	1
6	ROTULA CON CONO DI INVITO / BALL WITH CHAMFER	2
7	ROTULA CON DISTANZIALI / BALL WITH DISTANCE RINGS	2
8	ROTULA PER GANCIO SUPERIORE / BALL FOR UPPER HITCH	1

**KIT CATEGORIA 2 E 3**  
**KIT CATEGORY 2 AND 3**

POS.	DESCRIZIONE DESCRIPTION	N.
1	GANCI INFERIORI " RAPID " DX E SX / LOWER HITCH RHS - LHS	1+1
2	GANCIO SUPERIORE " RAPID " FILETTATURA M27X3-M30X3-M36X3 UPPER HITCH "RAPID" THREAD - M27X3-M30X3-M36X3	1
3	DISTANZIALE REGOLABILE / ADJUSTABLE DISTANCE PIECE	1
4	CORDA COMANDO GANCI INFER. / LOWER HITCH CONTROL ROPE	1
5	CORDA COMANDO GANCI SUPER. / UPPER HITCH CONTROL ROPE	1
6	ROTULA CON CONO DI INVITO CAT. 2 / BALL WITH CHAMFER CAT.2	2
7	ROTULA CON DISTANZIALI CAT. 2 / BALL WITH DISTANCE RINGS CAT.2	2
8	ROTULA PER GANCIO SUPERIORE CAT. 2 / BALL FOR UPPER HITCH CAT.2	1
9	ROTULA CON CONO DI INVITO CAT. 3 / BALL WITH CHAMFER CAT.3	2
10	ROTULA CON DISTANZIALI CAT. 3 / BALL WITH DISTANCE RINGS CAT.3	2
11	ROTULA PER GANCIO SUPERIORE CAT. 3 / BALL FOR UPPER HITCH CAT.3	1

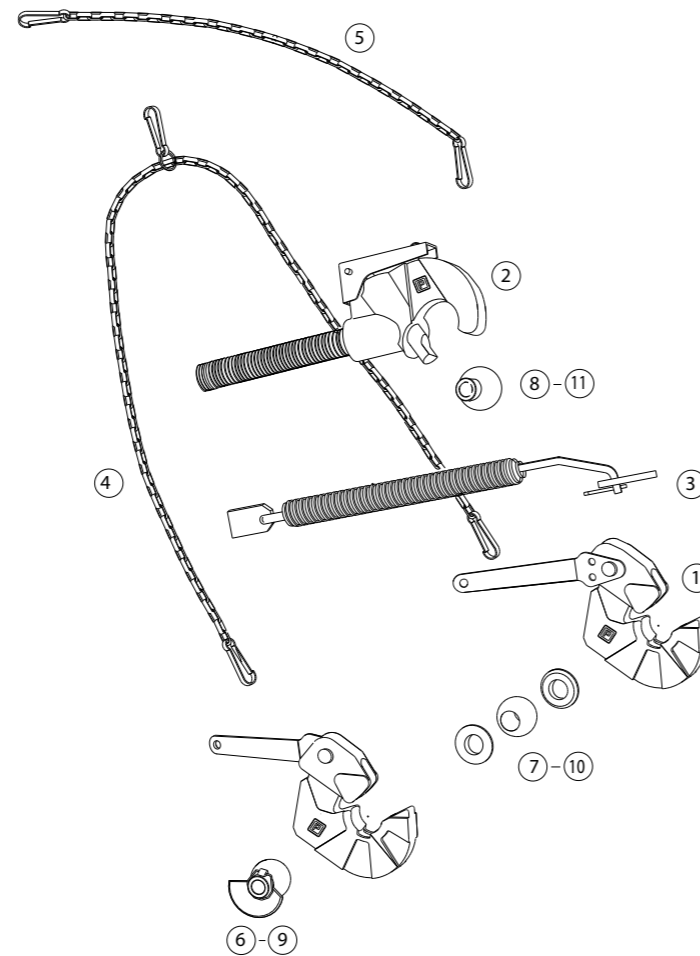

**NB: PER L'ORDINAZIONE SEGUIRE LA SEGUENTE TABELLA:**  
**PLEASE, FOR YOUR ORDERS TAKE THE FOLLOWING TABLE:**

SIGLA ARTICLE	CAT. KIT	FILETTATURA GANCIO SUP. "RAPID" THREAD UPPER HITCH " RAPID "
KAR 16	2	M27X3
KAR 17	2	M30X3
KAR 18	2	M36X3
KAR 19	3/2	M30X3
KAR 20	3/2	M36X3
KAR 21	3/2	M40X3

**RICAMBI PER GANCIO INFERIORE E SUPERIORE - "RAPID"**  
**SPARE PARTS FOR LOWER AND TOP HITCHES - "RAPID"**

SIGLA ARTICLE	DESCRIZIONE DESCRIPTION	POS.
CO 1950	CORPO GANCIO INFERIORE (DX - SX) BODY LOWER HICH	CAT 2 1
CO 1960	CORPO GANCIO INFERIORE (DX - SX) BODY UPPER HITCH	CAT 3 1
CA 1952	CAMME DI BLOCCAGGIO ROTULA (DX - SX) BALL LOCK	CAT 2 2
CA 1962	CAMME DI BLOCCAGGIO ROTULA (DX - SX) BALL LOCK	CAT 3 2
LE 1954	LEVA LAT CON VITE E DADO (DX - SX) SIDE LEVER WITH SCREW AND NUT	CAT 2 3
LE 1964	LEVA LAT CON VITE E DADO (DX - SX) SIDE LEVER WITH SCREW AND NUT	CAT 3 3
MO 1956	MOLLA CON RIBATTINO SPRING	CAT 2 4
MO 1966	MOLLA CON RIBATTINO SPRING	CAT 3 4
GA 1958	GANCIO PER BLOCCAGGIO CHIUSURA LOCKING HOOK	CAT 2/3 5

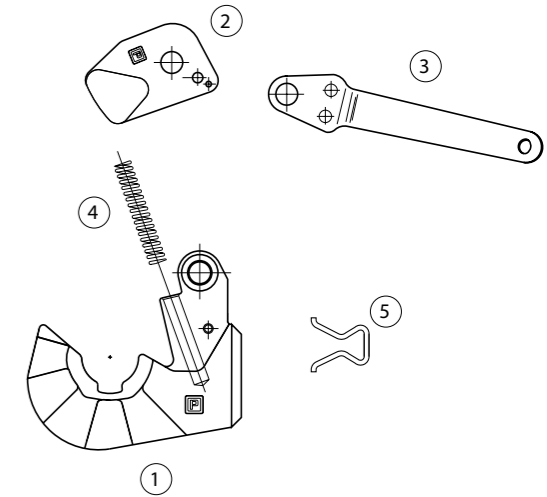

SIGLA ARTICLE	DESCRIZIONE DESCRIPTION	POS.
CO 2600	CORPO GANCIO SUPERIORE / BODY UPPER HITCH	CAT. 2 1
CO 2608	CORPO GANCIO SUPERIORE / BODY UPPER HITCH	CAT. 3 1
OT 2602	OTTURATORE / SHUTTER	CAT. 2 2
OT 2610	OTTURATORE / SHUTTER	CAT. 3 2
MO 2604	MOLLA / SPRING	CAT. 2 3
MO 2612	MOLLA / SPRING	CAT. 3 3
LE 2606	LEVA CON VITE E DADO / LEVER WITH SCREW AND NUT	CAT. 2 4
LE 2614	LEVA CON VITE E DADO + SPINA ELAST LEVER WITH SCREW AND NUT + ELASTIC PIN	CAT. 3 4

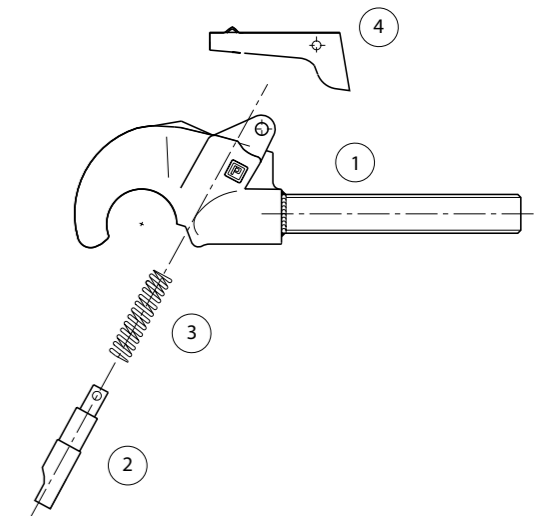

**NB: NELL'ORDINAZIONE SPECIFICARE IL FILETTO OPPURE SE TIPO DA SALDARE**  
**ATTENTION: WHILE ORDER GIVE DETAILS ABOUT THREAD OR WELDING**

TERMINALE A SNODO SFERICO AD ESTREMITA' RETTANGOLARE - FIANCHI DIRITTI  
 ACCOPPIAMENTO ACCIAIO SU ACCIAIO - CORPO IN ACCIAIO C 40 UNI EN 10083-1

BALL JOINT TERMINAL WITH RECTANGULAR END  
 COUPLING STEEL ON STEEL - ROD END OF STEEL C 40 UNI EN 10083-1

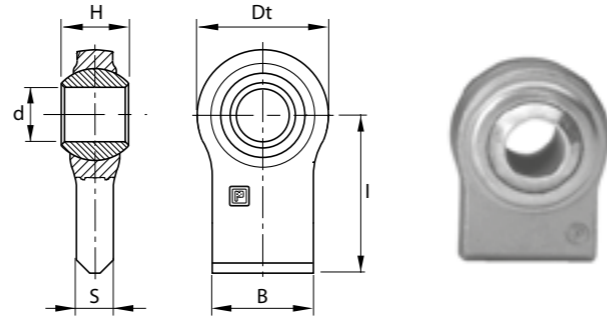

TYPE A

SIGLA ARTICLE	CAT.	d (A12)	H (h11)	B	S	Dt	I	TYPE	PESO IN Kg. WEIGHT Kg.
SR 10490	-	14	32	30	11	46	60	A	0.30
SR 10495	-	16	20	30	11	46	60	A	0.27
SR 10496	-	19	44	52	17	52	50	A	0.46
SR 10494	-	18	35	50	15	65	43	A	0.58
SR 10497	-	19	35	50	15	65	43	A	0.56
SR 10498	1	22.1	35	50	15	65	43	A	0.54
SR 10501	1	22.1	35	50	15	68	90	A	0.92
SR 10503	1	22.1	35	55	15	66	70	A	0.70
SR 10506	-	25.4	38	70	18	78	80	A	1.14
SR 10507	2	28.4	38	70	18	78	80	A	1.10
SR 10510	1	22.1	35	70	18	76	50	A	0.82
SR 10515	-	25.4	35	70	18	76	50	A	0.78
SR 10520	-	26	35	70	18	76	50	A	0.78
SR 10530	2	28.4	35	70	18	76	50	A	0.76
SR 10540	1	22.1	35	70	19	83	55	A	1.18
SR 10550	-	25.4	35	70	19	83	55	A	1.16
SR 10560	2	28.4	35	70	19	83	55	A	1.12
SR 10562	2	28.4	45	70	19	83	55	A	1.16
SR 10564	2	28.4	45	70	20	82	55	A	1.22
SR 10566	-	25.4	38	70	23	80	80	A	1.56
SR 10568	2	28.4	38	70	23	80	80	A	1.52
SR 10575	2	28.4	45	70	23	80	80	A	1.54
SR 10569	-	25.4	45	70	22	80	65	A	1.36
SR 10570	2	28.4	45	70	22	80	65	A	1.32
SR 10590	1/2	22.1/28.4	45	70	22	80	65	A	1.22
SR 10579	2	28.4	45	76	17	90	82	A	1.48
SR 10580	2	28.4	45	70	22	96	65	A	1.70
SR 10597	-	32	45	70	22	96	65	A	1.66
SR 10600	-	34	45	70	22	96	65	A	1.62
SR 10602	-	35	45	70	22	96	65	A	1.60
SR 10604	3	37	45	70	22	96	65	A	1.56
SR 10610	-	38	45	80	24	108	65	A	1.96
SR 10612	-	34	45	80	24	108	65	A	2.04
SR 10614	3	37	45	80	24	108	65	A	1.98
SR 10615	2	28.4	45	80	24	108	65	A	2.16
SR 10616	-	35	45	80	24	108	65	A	2.00
SR 10617	-	42	45	80	24	108	65	A	1.88

TERMINALE A SNODO SFERICO AD ESTREMITA' RETTANGOLARE - FIANCHI DIRITTI  
 ACCOPPIAMENTO ACCIAIO SU ACCIAIO - CORPO IN ACCIAIO C 40 UNI EN 10083-1

BALL JOINT TERMINAL WITH RECTANGULAR END  
 COUPLING STEEL ON STEEL - ROD END OF STEEL C 40 UNI EN 10083-1

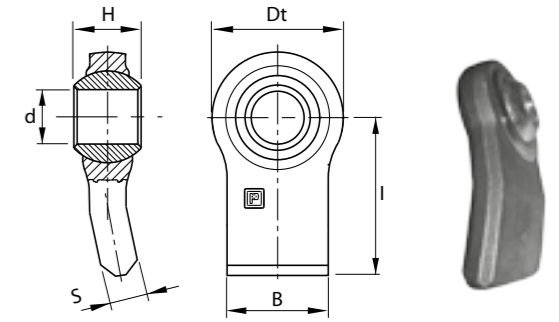

TYPE B

SIGLA ARTICLE	CAT.	d (A12)	H (h11)	B	S	Dt	I	TYPE	PESO IN Kg. WEIGHT Kg.
SR 10508	1	22.1	35	60	15	68	90	B	0.98
SR 10585	2	28.4	45	70	21	83	110	B	1.84
SR 10636	2	28.4	45	94	30	94	86	B	2.58
SR 10637	-	38	45	94	30	94	86	B	2.38

TERMINALE A SNODO SFERICO PER BRACCI INFERIORI - FIANCHI INCLINATI  
 ACCOPPIAMENTO ACCIAIO SU ACCIAIO CORPO IN ACCIAIO C 40 UNI EN 10083-1

WELD ON BALL ENDS  
 COUPLING STEEL ON STEEL - ROD END OF STEEL C 40 UNI EN 10083-1

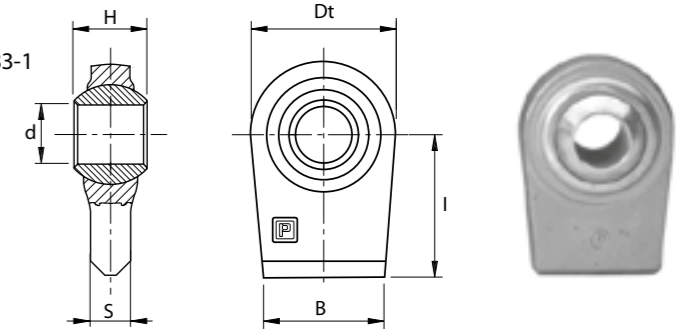

SIGLA ARTICLE	CAT.	d (A12)	H (h11)	B	S	Dt	I	PESO IN Kg. WEIGHT Kg.
SR 10499	-	19	35	60	18	67	50	0.74
SR 10500	1	22.1	35	60	18	67	50	0.72
SR 10505	1	22.1	35	58	18	67	75	0.94
SR 10576	2	28.4	45	70	18	85	80	1.44
SR 10577	1/2	22.1/28.4	45	70	18	85	80	1.34
SR 10578	2	28.4	35	70	18	85	80	1.40

TERMINALE A SNODO SFERICO CON FONDELLO  
 PER CILINDRI IDRAULICI A SALDARE  
 ACCOPPIAMENTO ACCIAIO SU ACCIAIO  
 CORPO IN ACCIAIO C40 UNI EN 10083-1

BALL JOINT TERMINAL WITH BULKHEAD TO BE WELDED  
 COUPLING STEEL ON STEEL ROD END OF STEEL C 40 UNI EN 10083-1

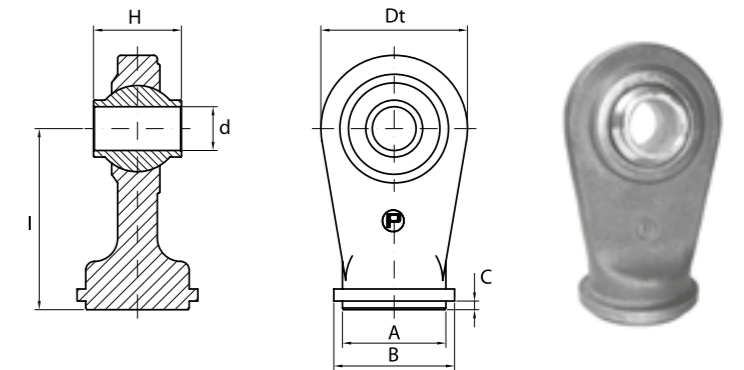

SIGLA ARTICLE	d (A12)	H (h11)	A (Ø)	B (Ø)	C	Dt	I	NOTE NOTE	PESO IN Kg. WEIGHT Kg.
SR 106025	25.4	51	60	70	5	85	105	BASE SPIANATA-FLAT BASE	2.25
SR 106325	25.4	51	63	73	5	85	105	BASE SPIANATA-FLAT BASE	2.28
SR 107025	25.4	51	70	80	5	85	105	BASE SPIANATA-FLAT BASE	2.36

TERMINALE A SNODO SFERICO PER BRACCI INFERIORI  
PIATTO PIEGATO TIPO FIAT 1000-1300  
ACCOPIAMENTO ACCIAIO SU ACCIAIO CORPO IN ACCIAIO C 40 UNI EN 10083-1

WELD ON BALL JOINT FOR ARM FIAT TYPE 1000 - 1300  
COUPLING STEEL ON STEEL - ROD END OF STEEL C 40 UNI EN 10083-1

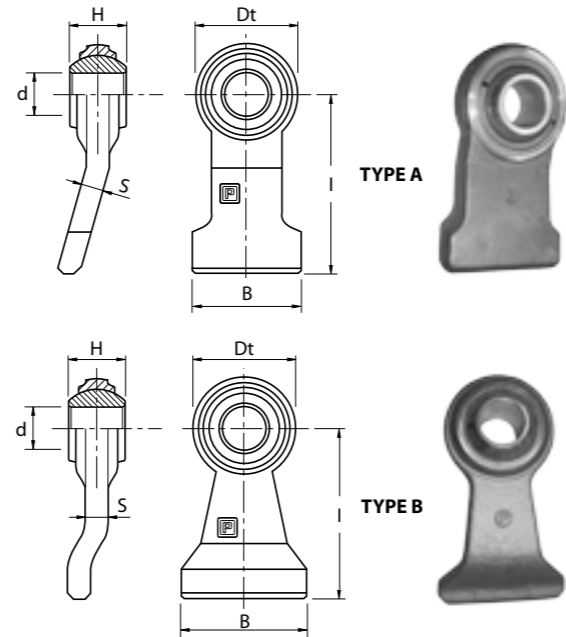

SIGLA ARTICLE	CAT.	d (A12)	H (h11)	B	S	Dt	I	PESO IN Kg. WEIGHT Kg.	TYPE	RIF. ORIG. FIAT ORIG. FIAT REF
SR 10620	2	28.4	45	100	21	80	130	2.24	B	01930293
SR 10621	2	28.4	45	100	32	100	130	3.52	A	-
SR 10622	-	35	45	100	32	100	130	3.38	A	4997106
SR 10624	3	37	45	100	32	100	130	3.34	A	-

TERMINALE A SNODO SFERICO SMONTABILE TIPO FIAT  
ACCOPIAMENTO ACCIAIO SU ACCIAIO - CORPO IN ACCIAIO C 40 UNI EN 10083-1

BALL ENDS FIAT TYPE  
COUPLING STEEL ON STEEL - ROD END OF STEEL C 40 UNI EN 10083-1

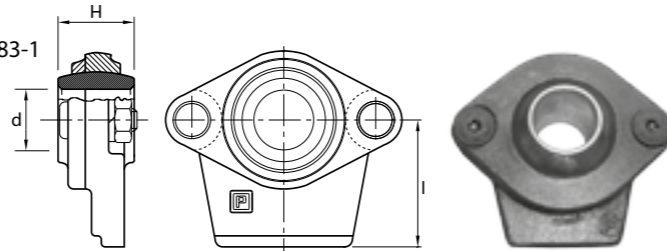

SIGLA ARTICLE	CAT.	d (A12)	H (h11)	I	PESO IN Kg. WEIGHT Kg.
SR 10680	1	22.1	35	55	1.40
SR 10670	-	25.4	35	55	1.36
SR 10690	2	28.4	35	55	1.32
SR 10685	-	25.4	45	55	1.40
SR 10689	2	28.4	45	55	1.36

ROTULE DI RICAMBIO  
BALLS SPARE PARTS

SIGLA ARTICLE	CAT.	d (A12)	D	H (h11)	IMPIEGO APPLICATION	PESO IN Kg. WEIGHT Kg.
RS 10681	1	22.1	56	35	SR 10680	0.48
RS 10682	-	25.4	56	45	SR 10685	0.48
SF 10993	2	28.4	56	45	SR 10689	0.44
RS 10691	2	28.4	56	35	SR 10690	0.40
RS 10692	-	25.4	56	35	SR 10670	0.44

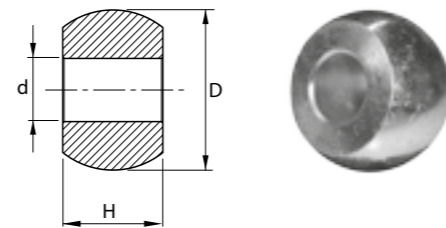

TERMINALE A SNODO SFERICO AD ESTREMITA' ROTONDA  
PER CILINDRI IDRAULICI DA SALDARE  
ACCOPIAMENTO ACCIAIO SU ACCIAIO CORPO IN ACCIAIO C 40 UNI EN 10083-1

BALL JOINT TERMINAL WITH ROUND END TO BE WELDED  
COUPLING STEEL ON STEEL  
ROD END OF STEEL C 40 UNI EN 10083-1

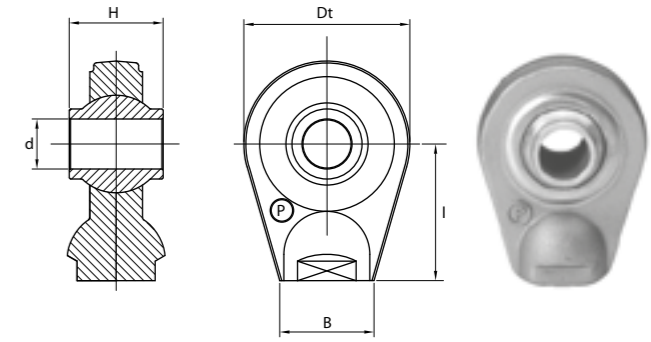

SIGLA ARTICLE	CAT.	d (A12)	H (h11)	B (Ø)	Dt	I	Df	Pf	NOTE NOTE	PESO IN Kg. WEIGHT Kg.
SR 10705	1	19	44	30	62	50	-	-	BASE SPIANATA-FLAT BASE	0.54
SR 10707	-	22.1	44	34	62	58	-	-	BASE SPIANATA-FLAT BASE	0.58
SR 10708	1	19	44	34	62	58	-	-	BASE SPIANATA-FLAT BASE	0.60
SR 10709	-	20	44	34	62	58	-	-	BASE SPIANATA-FLAT BASE	0.59
SR 10710	1	19	44	34	62	60	-	-	BASE SPIANATA-FLAT BASE	0.62
SR 10712	-	22.1	44	34	62	60	-	-	BASE SPIANATA-FLAT BASE	0.60
SR 10720	-	20	44	34	62	60	-	-	BASE SPIANATA-FLAT BASE	0.61
SR 10724	1	19	35	26	62	50	-	-	BASE SPIANATA-FLAT BASE	0.54
SR 10725	-	22.1	35	26	62	50	-	-	BASE SPIANATA-FLAT BASE	0.52
SR 10727	1	19	35	30	70	46	-	-	BASE SPIANATA-FLAT BASE	0.64
SR 10730	-	22.1	51	38	75	65	-	-	BASE SPIANATA-FLAT BASE	0.98
SR 10735	2	25.4	40	38	75	65	-	-	BASE SPIANATA-FLAT BASE	0.90
SR 10737	1	19	51	38	75	65	-	-	BASE SPIANATA-FLAT BASE	1.02
SR 10739	-	30	51	38	75	65	-	-	BASE SPIANATA-FLAT BASE	0.88
SR 10740	2	25.4	51	38	75	65	-	-	BASE SPIANATA-FLAT BASE	0.94
SR 10741	2	25.4	51	31	75	70	-	-	BASE SPIANATA-FLAT BASE	0.90
SR 10742	2	25.4	51	45	72	70	-	-	BASE SPIANATA-FLAT BASE	1.14
SR 10744	1	19	51	45	72	70	-	-	BASE SPIANATA-FLAT BASE	1.22
SR 10746	-	22.1	51	45	72	70	-	-	BASE SPIANATA-FLAT BASE	1.18
SR 10748	-	30	51	45	72	70	-	-	BASE SPIANATA-FLAT BASE	1.08
SR 10756	-	22.1	51	50	85	70	-	-	BASE SPIANATA-FLAT BASE	1.64
SR 10759	1	19	51	50	85	70	-	-	BASE SPIANATA-FLAT BASE	1.68
SR 10760	2	25.4	51	50	85	70	-	-	BASE SPIANATA-FLAT BASE	1.62
SR 10780	-	30	51	50	85	70	-	-	BASE SPIANATA-FLAT BASE	1.56
SR 10791	2	25.4	51	40	90	85	-	-	BASE SPIANATA-FLAT BASE	1.68
SR 10792	-	30	51	40	90	85	-	-	BASE SPIANATA-FLAT BASE	1.64
SR 10793	3	32	51	40	90	85	-	-	BASE SPIANATA-FLAT BASE	1.58
SR 10795	-	35	55	40	90	85	-	-	BASE SPIANATA-FLAT BASE	1.52
SR 10796	1/2	19/25.4	45X45	40	90	85	-	-	BASE SPIANATA-FLAT BASE	1.56
SR 10750	2	25.4	51	50	83	65	-	-	BASE SPIANATA-FLAT BASE	1.38
SR 10800	-	29	55	50	83	65	-	-	BASE SPIANATA-FLAT BASE	1.38
SR 10805	-	30	42	50	83	65	-	-	BASE SPIANATA-FLAT BASE	1.30
SR 10807	3	32	51	50	83	65	-	-	BASE SPIANATA-FLAT BASE	1.30
SR 10810	-	30	55	50	83	65	-	-	BASE SPIANATA-FLAT BASE	1.36
SR 10812	-	35	35	50	83	65	-	-	BASE SPIANATA-FLAT BASE	1.20
SR 10815	-	35	55	50	83	65	-	-	BASE SPIANATA-FLAT BASE	1.24
SR 10816	-	29	55	50	92	65	-	-	BASE SPIANATA-FLAT BASE	1.60
SR 10817	-	30	55	50	92	65	-	-	BASE SPIANATA-FLAT BASE	1.58
SR 10818	-	30	42	50	92	65	-	-	BASE SPIANATA-FLAT BASE	1.52
SR 10825	3	32	51	50	92	65	-	-	BASE SPIANATA-FLAT BASE	1.54
SR 10819	-	35	35	50	92	65	-	-	BASE SPIANATA-FLAT BASE	1.42
SR10821	-	40	75	58	108	60	-	-	BASE SPIANATA-FLAT BASE	2.76
SR 10841	-	45	75	58	108	60	-	-	BASE SPIANATA-FLAT BASE	2.56
SR 10861	-	50	75	58	108	60	-	-	BASE SPIANATA-FLAT BASE	2.36
SR 10820	-	40	75	60	108	85	-	-	BASE SPIANATA-FLAT BASE	3.42
SR 10840	-	45	75	60	108	85	-	-	BASE SPIANATA-FLAT BASE	3.22
SR 10860	-	50	75	60	108	85	-	-	BASE SPIANATA-FLAT BASE	3.02

A RICHIESTA FORO (d) RETTIFICATO  
RECTIFIED HOLE (d) REQUEST

TERMINALE A SNODO SFERICO AD ESTREMITA' ROTONDA  
PER CILINDRI IDRAULICI DA SALDARE  
ACCOPIAMENTO ACCIAIO SU ACCIAIO  
CORPO IN ACCIAIO C 40 UNI EN 10083-1

BALL JOINT TERMINAL WITH ROUND END TO BE WELDED  
COUPLING STEEL ON STEEL  
ROD END OF STEEL C 40 UNI EN 10083-1

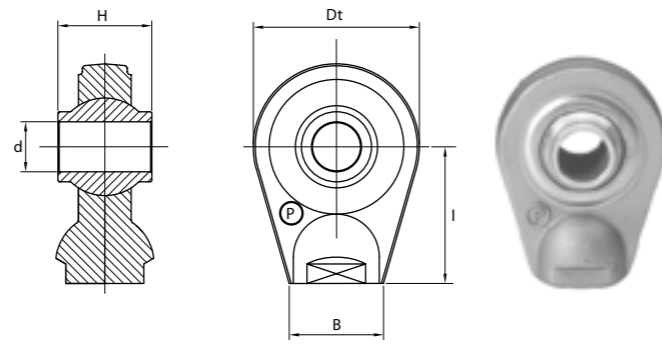

SIGLA ARTICLE	CAT.	d (A12)	H (h11)	B (Ø)	Dt	I	Df	Pf	NOTE NOTE	PESO IN Kg. WEIGHT Kg.
SR 10693	-	14	44	25	55	50	-	-	BASE GREZZA-ROUGH BASE	0.46
SR 10694	1	19	30	25	55	50	-	-	BASE GREZZA-ROUGH BASE	0.40
SR 10695	1	19	44	25	55	50	-	-	BASE GREZZA-ROUGH BASE	0.42
SR 10696	-	20	44	25	55	50	-	-	BASE GREZZA-ROUGH BASE	0.41
SR 10697	1	19	44	26	55	65	-	-	BASE GREZZA-ROUGH BASE	0.50

A RICHIESTA FORO (d) RETTIFICATO  
RECTIFIED HOLE (d) REQUEST

TERMINALE A SNODO SFERICO AD ESTREMITA' ROTONDA  
PER CILINDRI IDRAULICI CON FILETTATURA INTERNA  
ACCOPIAMENTO ACCIAIO SU ACCIAIO  
CORPO IN ACCIAIO C 40 UNI EN 10083-1

BALL JOINT TERMINAL WITH ROUND END  
WITH INNER THREAD COUPLING STEEL ON STEEL  
ROD END OF STEEL C 40 UNI EN 10083-1

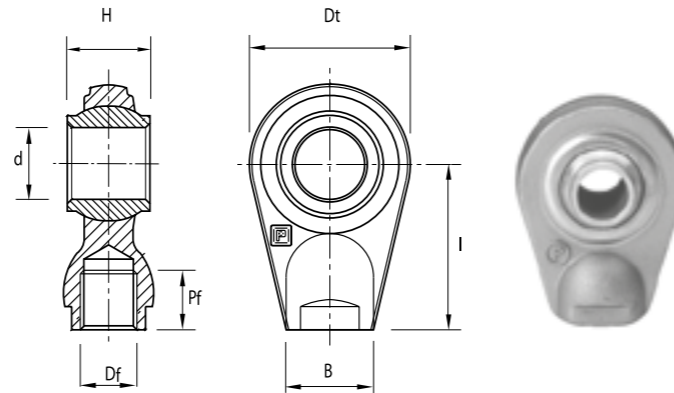

SIGLA ARTICLE	CAT.	d (A12)	H (h11)	B (Ø)	Dt	I	Df	Pf	NOTE NOTE	PESO IN Kg. WEIGHT Kg.
SR 10768	-	22.1	51	50	85	70	M27X2	27	BASE SPIANATA-FLAT BASE	1.50
SR 10769	1	19	51	50	85	70	M27X2	27	BASE SPIANATA-FLAT BASE	1.54
SR 10770	2	25.4	51	50	85	70	M27X2	27	BASE SPIANATA-FLAT BASE	1.46
SR 10790	-	30	51	50	85	70	M27X2	27	BASE SPIANATA-FLAT BASE	1.40
SR 10794	3	32	51	40	90	85	M27X2	27	BASE SPIANATA-FLAT BASE	1.44
SR 10830	-	40	75	60	108	85	M38X2	28	BASE SPIANATA-FLAT BASE	3.10
SR 10850	-	45	75	60	108	85	M38X2	28	BASE SPIANATA-FLAT BASE	2.90
SR 10870	-	50	75	60	108	85	M38X2	28	BASE SPIANATA-FLAT BASE	2.70

A RICHIESTA FORO (d) RETTIFICATO  
RECTIFIED HOLE (d) REQUEST

TERMINALE A SNODO SFERICO A BASE RETTANGOLARE  
PER CILINDRI IDRAULICI DA SALDARE  
ACCOPIAMENTO ACCIAIO SU ACCIAIO  
CORPO IN ACCIAIO C 40 UNI EN 10083-1

BALL JOINT TERMINAL WITH RECTANGULAR END TO BE WELDED  
COUPLING STEEL ON STEEL  
ROD END OF STEEL C 40 UNI EN 10083-1

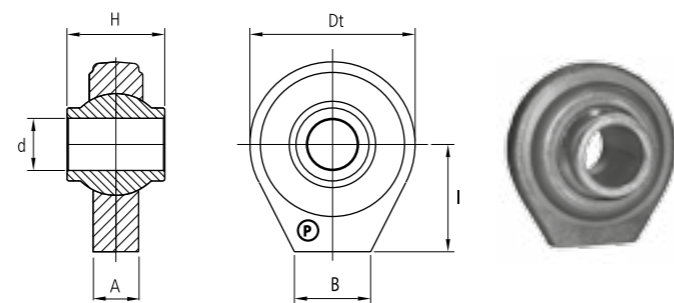

SIGLA ARTICLE	CAT.	d (A12)	H (h11)	BxA	Dt	I	Df	Pf	NOTE NOTE	PESO IN Kg. WEIGHT Kg.
SR 10700	1	19	44	30X13	62	34	-	-	BASE GREZZA-ROUGH BASE	0.44
SR 10702	-	20	44	30X13	62	34	-	-	BASE GREZZA-ROUGH BASE	0.43
SR 10704	-	22.1	44	30X13	62	34	-	-	BASE GREZZA-ROUGH BASE	0.42

A RICHIESTA FORO (d) RETTIFICATO  
RECTIFIED HOLE (d) REQUEST

TERMINALE A SNODO SFERICO AD ESTREMITA' ROTONDA  
PER CILINDRI IDRAULICI DA SALDARE  
ACCOPIAMENTO ACCIAIO SU ACCIAIO  
CORPO IN ACCIAIO C 40 UNI EN 10083-1

BALL JOINT TERMINAL WITH ROUND END TO BE WELDED  
COUPLING STEEL ON STEEL  
ROD END OF STEEL C 40 UNI EN 10083-1

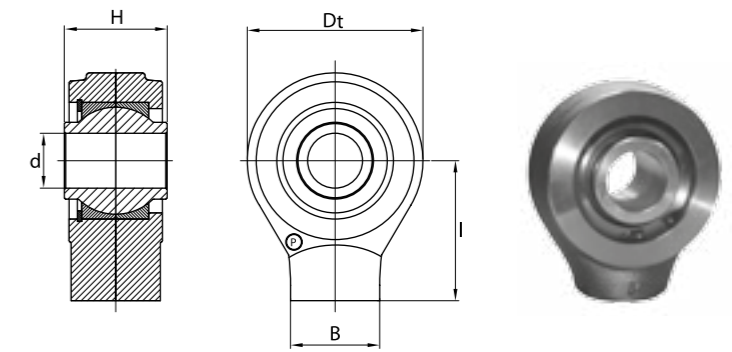

(\*) CON DUE SEDI RIPOSTATE REGISTRABILI  
(\*) WITH TWO SEATINGS TRANSFERRED ADJUSTABLE

SIGLA ARTICLE	CAT.	d (A12)	H (h11)	B (Ø)	Dt	I	Df	Pf	NOTE NOTE	PESO IN Kg. WEIGHT Kg.
SR 10871 (*)	-	40	75	65	128	85	-	-	BASE SPIANATA-FLAT BASE	6.38
SR 10872 (*)	-	45	75	65	128	85	-	-	BASE SPIANATA-FLAT BASE	6.18
SR 10873 (*)	-	50	75	65	128	85	-	-	BASE SPIANATA-FLAT BASE	5.98

A RICHIESTA FORO (d) RETTIFICATO  
RECTIFIED HOLE (d) REQUEST

TERMINALE A SNODO SFERICO AD ESTREMITA' ROTONDA  
PER CILINDRI IDRAULICI CON FILETTATURA INTERNA  
ACCOPIAMENTO ACCIAIO SU ACCIAIO  
CORPO IN ACCIAIO C 40 UNI EN 10083-1

BALL JOINT TERMINAL WITH ROUND END  
WITH INNER THREAD COUPLING STEEL ON STEEL  
ROD END OF STEEL C 40 UNI EN 10083-1

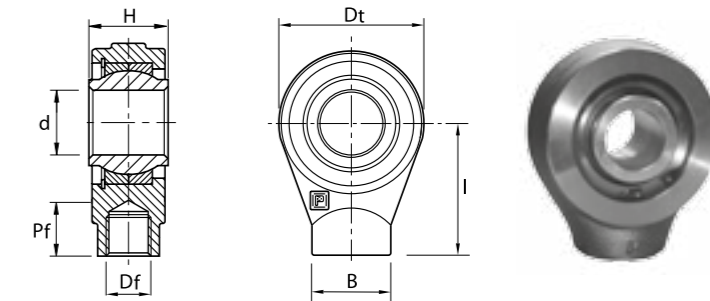

(\*) CON DUE SEDI RIPOSTATE REGISTRABILI  
(\*) WITH TWO SEATINGS TRANSFERRED ADJUSTABLE

SIGLA ARTICLE	CAT.	d (A12)	H (h11)	B (Ø)	Dt	I	Df	Pf	NOTE NOTE	PESO IN Kg. WEIGHT Kg.
SR 10874 (*)	-	40	75	65	128	85	M38X2	28	BASE SPIANATA-FLAT BASE	6.16
SR 10875 (*)	-	45	75	65	128	85	M38X2	28	BASE SPIANATA-FLAT BASE	5.96
SR 10876 (*)	-	50	75	65	128	85	M38X2	28	BASE SPIANATA-FLAT BASE	5.76

A RICHIESTA FORO (d) RETTIFICATO  
RECTIFIED HOLE (d) REQUEST

TERMINALE A SNODO SFERICO AD ESTREMITA' ROTONDA  
PER CILINDRI IDRAULICI DA SALDARE  
ACCOPIAMENTO ACCIAIO SU ACCIAIO  
CORPO IN ACCIAIO C 40 UNI EN 10083-1

BALL JOINT TERMINAL WITH ROUND END TO BE WELDED  
COUPLING STEEL ON STEEL  
ROD END OF STEEL C 40 UNI EN 10083-1

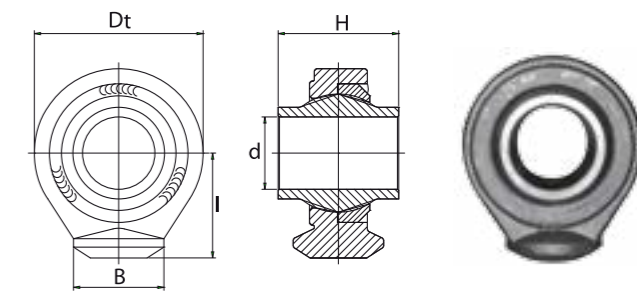

SIGLA ARTICLE	CAT.	d (A12)	H (h11)	B (Ø)	Dt	I	Df	Pf	NOTE NOTE	PESO IN Kg. WEIGHT Kg.
SR 10880	-	60 (H7)	100	75	140	87	-	-	BASE SPIANATA-FLAT BASE	5.66



TERMINALE A SNODO SFERICO AD ESTREMITA' ROTONDA  
PER CILINDRI IDRAULICI DA SALDARE  
ACCOPIAMENTO ACCIAIO SU ACCIAIO  
CORPO IN ACCIAIO C 40 UNI EN 10083-1

BALL JOINT TERMINAL WITH ROUND END TO BE WELDED.  
COUPLING STEEL ON STEEL - ROD END OF STEEL C 40 UNI EN 10083-1

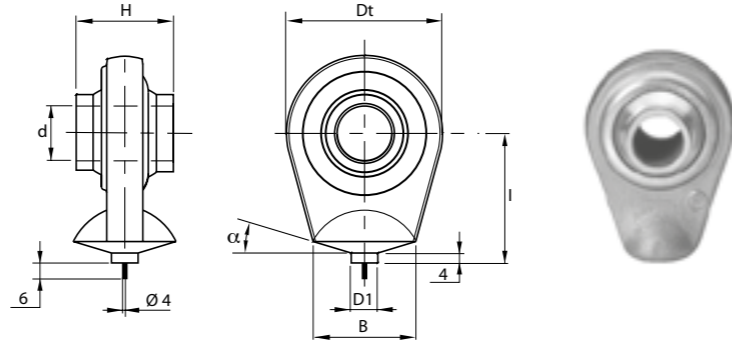

SIGLA ARTICLE	CAT.	d (A12)	H (h11)	B (Ø)	Dt	I	D1	GRADI DEGREE α	PESO IN Kg. WEIGHT Kg.
SR 10731	1	19	51	35	75	55	12	15	0.88
SR 10732	-	22.1	51	35	75	55	12	15	0.87
SR 10736	2	25.4	51	35	75	55	12	15	0.84
SR 10733	-	28.4	51	35	75	55	12	15	0.82
SR 10738	-	30	51	35	75	55	12	15	0.78
SR 10808	-	30	55	45	83	65	20	20	1.50
SR 10811	3	32	51	45	83	65	20	20	1.40
SR 10814	-	35	55	45	83	65	20	20	1.42

TERMINALE CON SNODO SFERICO SMONTABILE  
ACCOPIAMENTO ACCIAIO SU ACCIAIO  
CORPO IN ACCIAIO C 40 UNI EN 10083-1

HOUSING WITH DISMOUNTABLE BALL JOINT  
COUPLING STEEL ON STEEL - ROD END OF STEEL C 40 UNI EN 10083-1

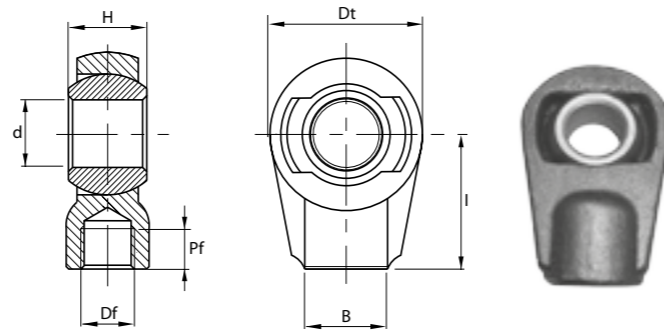

A RICHIESTA SI ESEGUONO FILETTATURE SPECIALI  
ON YOUR REQUEST WE MAKE CUSTOMISED THREADING

SIGLA ARTICLE	d (H10)	H (h11)	B (Ø)	Dt	I	Df	Pf	NOTE NOTE	PESO IN Kg. WEIGHT Kg.
SR 10900	16	20	27	44	45	M16X1.5	20	BASE SPIANATA-FLAT BASE	0.28
SR 10910	20	20	27	44	45	M18X1.5	20	BASE SPIANATA-FLAT BASE	0.25
SR 10920	25	30	35	61	60	M20X1.5	25	BASE SPIANATA-FLAT BASE	0.80
SR 10930	30	30	35	61	60	M22X1.5	25	BASE SPIANATA-FLAT BASE	0.72
SR 10940	35	40	45	80	80	M27X2	35	BASE SPIANATA-FLAT BASE	1.70
SR 10950	40	40	45	80	80	M30X2	35	BASE SPIANATA-FLAT BASE	1.60

ATTACCHI SNODATI PER 3° PUNTO  
ARTICULATED YOKE FOR 3° POINT LINKAGE

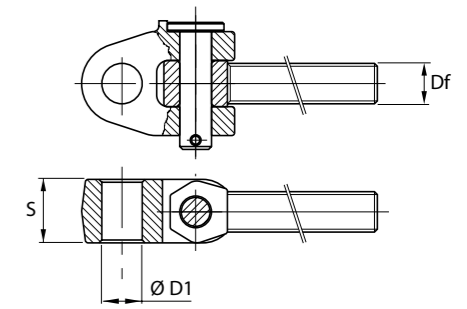

SIGLA ARTICLE	CAT.	Df	Ø D1	S
CPF 1400	2	M30X3 DX	25.4	51
CPF 1402	2	M30X3 SX	25.4	51
CPF 1404	-	M30X3 DX	28	51
CPF 1406	-	M30X3 SX	28	51
CPF 1408	-	M30X3 DX	30	51
CPF 1410	-	M30X3 SX	30	51
CPF 1412	3	M30X3 DX	32	51
CPF 1414	3	M30X3 SX	32	51
CPF 1416	1	M30X3.5 DX	19	51
CPF 1418	1	M30X3.5 SX	19	51
CPF 1420	-	M30X3.5 DX	20	51
CPF 1422	-	M30X3.5 SX	20	51
CPF 1424	-	M30X3.5 DX	22.1	51
CPF 1426	-	M30X3.5 SX	22.1	51
CPF 1428	2	M30X3.5 DX	25.4	51
CPF 1430	2	M30X3.5 SX	25.4	51

SIGLA ARTICLE	CAT.	Df	Ø D1	S
CPF 1432	-	M36x3 DX	20	51
CPF 1434	-	M36x3 SX	20	51
CPF 1436	-	M36x3 DX	22.1	51
CPF 1438	-	M36x3 SX	22.1	51
CPF 1440	2	M36x3 DX	25.4	51
CPF 1442	2	M36x3 SX	25.4	51
CPF 1444	-	M36x3 DX	28	51
CPF 1446	-	M36x3 SX	28	51
CPF 1448	-	M36x3 DX	30	51
CPF 1450	-	M36x3 SX	30	51
CPF 1452	3	M36x3 DX	32	51
CPF 1454	3	M36x3 SX	32	51

FORCELLA A CROCERA  
SHIFTER

SIGLA ARTICLE	Ø D	Ø D1	I	H	L	S	R	PESO IN Kg. WEIGHT Kg.
FC 1460	28	19	63	40	85	51	25.5	1.94
FC 1461	28	20	63	40	85	51	25.5	1.96
FC 1462	28	22.1	63	40	85	51	25.5	1.92
FC 1463	28	25.4	63	40	85	51	25.5	1.88
FC 1464	28	28	63	40	85	51	25.5	1.84
FC 1465	28	30	63	40	85	51	25.5	1.78
FC 1466	28	32	63	40	85	51	25.5	1.74
FC 1467	28	36	63	40	85	51	25.5	1.66
FC 1470	28	28	57	40	75	65	28	1.46

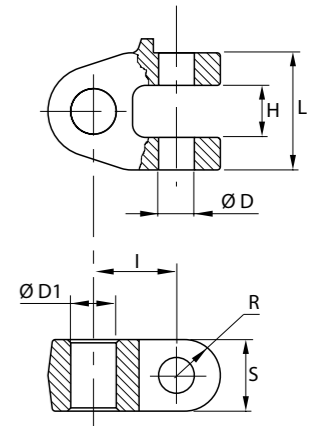

TIRANTE FILETTATO PER FORCELLA A CROCERA  
THREADENED END ASSEMBLIES FOR SHIFTER

SIGLA ARTICLE	Df	PESO IN Kg. WEIGHT Kg.
PF 1480	M30X3 DX	1.42
PF 1482	M30X3 SX	1.42
PF 1484	M30X3.5 DX	1.40
PF 1486	M30X3.5 SX	1.40
PF 1488	M36X3 DX	1.84
PF 1490	M36X3 SX	1.84
PGG 1500	A GAMBO GREZZO Ø36 - Ø36 NOT TURNED	2.00

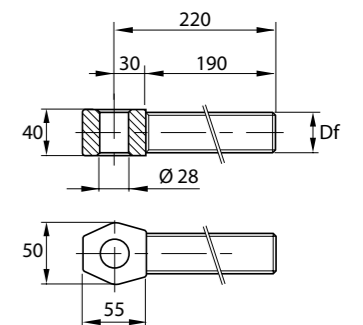

PERNO  
PIN

SIGLA ARTICLE	D	Q	L2	d	PESO IN Kg. WEIGHT Kg.
PF 11194	28	34X34	80	6	0.60
PF 11195	28	34X34	90	6	0.60

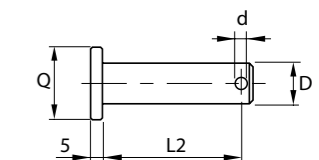

STABILIZZATORI LATERALI RIGIDI FIAT  
RIGID STABILISERS FOR TRACTORS FIAT

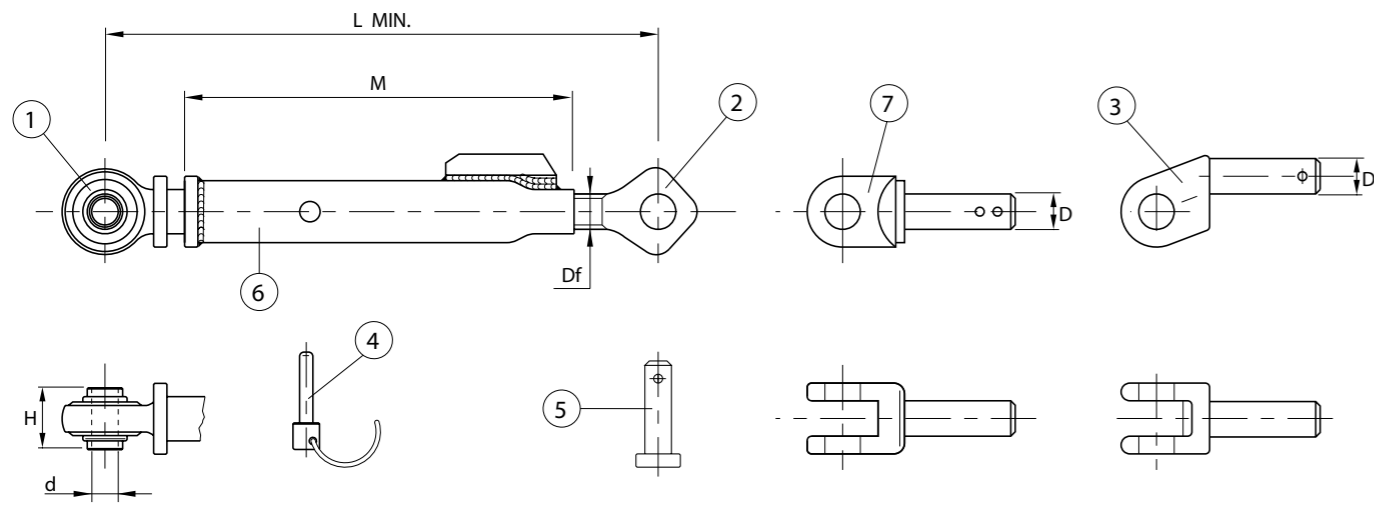

SIGLA ARTICLE	L. MIN.	M	Df	d	H	D	IMPIEGO TRATTORI SERIE PESANTE APPLICATION HEAVY TRACTORS	RIF. ORIGINALE FIAT ORIGINAL "FIAT" REF.	PESO IN Kg. WEIGHT Kg.
<b>SLF 12290</b> FORCELLA PIEGATA BENT CLEVIS	480	380	M30X3 DX	25.4	51	28	<b>FIAT</b> : 1180 - 1380 - 1580 1880 - 115/90 - 130/90 140/90 - 160/90 - 180/90	5109518	8.50

SIGLA ARTICLE	POS.	RICAMBI - DESCRIZIONE SPARE PARTS - DESCRIPTION	RIF. ORIGINALE FIAT ORIGINAL "FIAT" REF.	PESO IN Kg. WEIGHT Kg.
<b>SLF 12291</b>	1	TIRANTE LISCIO - GAMBO Ø 37 - ROD Ø 37	5109486	2.26
<b>SLF 12292</b>	2	TIRANTE FILETTATO - M30X3 DX - THREADED ROD - M30X3 DX	5109487	1.18
<b>SLF 12293</b>	3	FORCELLA INCLINATA CON PERNO D'ATTACCO Ø 28 - SLOPING CLEVIS WITH PIN Ø 28	5109502	1.30
<b>SLF 12294</b>	4	SPINA DI SICUREZZA A SCATTO - Ø 19 - SECURITY PIN - Ø 19	5105520	0.34
<b>SLF 12295</b>	5	PERNO Ø 25 PER ATTACCO FORCELLA - PIN Ø 25	5104572	0.32
<b>SLF 12296</b>	6	MANICOTTO STABILIZZATORE - M30X3 DX - SLEEVE - M30X3 DX	5109519	3.10

SIGLA ARTICLE	L. MIN.	M	Df	d	H	D	IMPIEGO TRATTORI SERIE LEGGERA LIGHT TRACTORS	RIF. ORIGINALE FIAT ORIGINAL "FIAT" REF.	PESO IN Kg. WEIGHT Kg.
<b>SLF 12298</b> FORCELLA PIEGATA BENT CLEVIS	400	320	M27X3 DX	19	44	26	<b>FIAT</b> : 666 - 680 - 680H - 766 - 780 880 - 980 - 70/66 - 80/66	5123273	5.32
<b>SLF 12300</b> FORCELLA DIRITTA STRAIGHT CLEVIS	400	320	M27X3 DX	19	44	26	70/90 - 80/90 - 90/90 - 100/90	5113070	5.26

SIGLA ARTICLE	POS.	RICAMBI - DESCRIZIONE SPARE PARTS - DESCRIPTION	RIF. ORIGINALE FIAT ORIGINAL "FIAT" REF.	PESO IN Kg. WEIGHT Kg.
<b>SLF 12301</b>	7	FORCELLA DIRITTA CON PERNO D'ATTACCO Ø 26 (SLF 12300) - CLEVIS WITH PIN Ø 26 (SLF 12300)	5113071	0.74
<b>SLF 12302</b>	1	TIRANTE LISCIO - GAMBO Ø 30 - ROD Ø 30	5103858	1.40
<b>SLF 12303</b>	2	TIRANTE FILETTATO - M27X3 DX - THREADED ROD - M27X3 DX	5103856	0.76
<b>SLF 12304</b>	3	FORCELLA INCLINATA CON PERNO D'ATTACCO Ø 26 (SLF 12298) - SLOPING CLEVIS WITH PIN Ø 26 (SLF 12298)	5123274	0.80
<b>SLF 12305</b>	4	SPINA DI SICUREZZA A SCATTO - Ø 16 - SECURITY PIN - Ø 16	5103862	0.20
<b>SLF 12306</b>	5	PERNO Ø 20 PER ATTACCO FORCELLA - PIN Ø 20	5103861	0.16
<b>SLF 12307</b>	6	MANICOTTO STABILIZZATORE - M27X3 DX - SLEEVE - M27X3 DX	5103857	2.00

STABILIZZATORI RIGIDI PER TRATTORI "RENAULT"  
RIGID STABILISERS FOR TRACTORS RENAULT

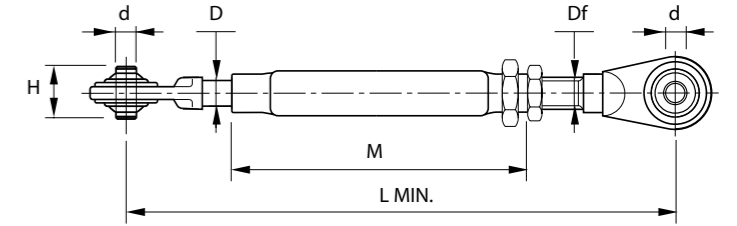

SIGLA ARTICLE	L. MIN.	M	Df	d (A12)	H (h11)	D	TIRANTE END ASSEMBLY		PESO IN Kg. WEIGHT Kg.
							DX (RHS)	SX (LHX)	
<b>SLR 12042</b>	570	465	M24X3	22.1	35	18.5	TF 10331	- TT 10332	3.64
<b>SLR 12046</b>	690	585	M24X3	22.1	35	18.5	TF 10331	- TT 10332	4.12
<b>SLR 12048</b>	655	525	M27X3	28.4	45	22	TF 10351	- TT 10352	5.52

TIRANTI PER STABILIZZATORI "RENAULT"  
END ASSEMBLIES FOR STABILISERS RENAULT

SIGLA ARTICLE	d (A12)	H (h11)	Df	D	L	Lf	I	Dt	PESO IN Kg. WEIGHT Kg.
<b>TF 10331</b>	22.1	35	M24X3 DX	-	175	130	45	64	0.98
<b>TF 10351</b>	28.4	45	M27X3 DX	-	240	180	60	80	1.82
<b>TT 10332</b>	22.1	35	GAMBO TORNITO TURNED ROD	18.5	220	-	45	64	0.96
<b>TT 10352</b>	28.4	45		22	240	-	60	80	1.66

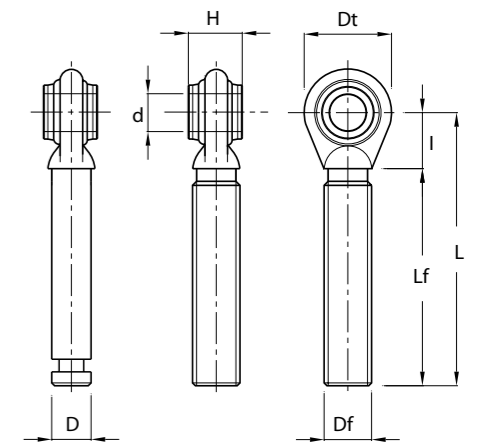

STABILIZZATORI LATERALI RIGIDI PER TRATTORI  
RIGID STABILISERS FOR TRACTOR

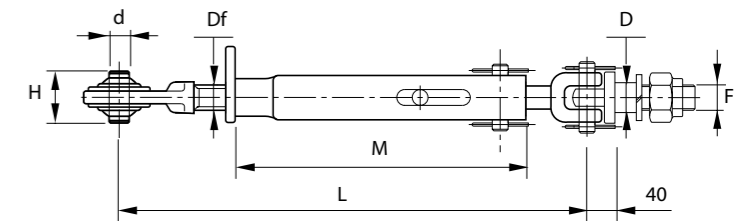

SIGLA ARTICLE	L		M	Df	d (A12)	H (h11)	D	F	NOTE	PESO IN Kg. WEIGHT Kg.
	MIN.	MAX								
<b>SL 12000</b>	470	620	355	M27X3	19	44	20	M20X2.5	SENZA ASOLA - NO EYELET	4.76
<b>SL 12010</b>	440	600	315	M27X3	19	44	28	M24X2	CON ASOLA - WITH EYELET	4.80
<b>SL 12020</b>	440	600	315	M27X3	25.4	51	28	M24X2	CON ASOLA - WITH EYELET	5.26
<b>SL 12030</b>	510	670	395	M27X3	19	44	28	M24X2	CON ASOLA - WITH EYELET	4.86
<b>SL 12040</b>	510	670	395	M27X3	25.4	51	28	M24X2	CON ASOLA - WITH EYELET	5.32

BRACCIO DI SOLLEVAMENTO LATERALE REGISTRABILE  
ADJUSTABLE LEVELLING ARM

SIGLA ARTICLE	L		M	Df	D	D1	H	h	H1	h1	PESO IN Kg. WEIGHT Kg.
	MIN.	MAX									
BL 11900	380	520	230	M22X2.5	18	18	30	37	24	72	2.74
BL 11905	400	480	230	M22X2.5	18	26	30	37	24	93	3.24
BL 11910	440	600	260	M24X2.5	18	18	40	70	24	72	3.42
BL 11915	530	690	370	M24X2.5	18	22	30	37	24	72	4.00
BL 11920	500	690	320	M27X3	18	18	40	70	24	72	3.54

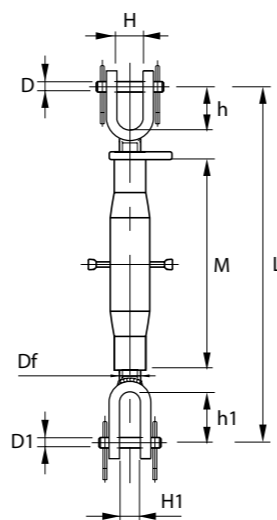

BRACCIO DI SOLLEVAMENTO LATERALE CON FORCELLA E TIRANTE  
ADJUSTABLE LEVELLING ARM WITH BALL END

SIGLA ARTICLE	L		M	Df	d (A12)	D1	H (h11)	H1	h1	PESO IN Kg. WEIGHT Kg.
	MIN.	MAX								
BL 11930	380	530	225	M24X3	19	18	44	24	72	2.74
BL 11931	380	530	225	M24X3	22.1	18	35	24	72	2.84
BL 11940	420	570	275	M24X3	19	18	44	24	72	2.84
BL 11941	420	570	275	M24X3	22.1	18	35	24	72	2.94
BL 11943	510	660	360	M24X3	19	18	44	24	72	3.12
BL 11947	580	730	430	M24X3	22.1	18	35	24	72	3.26

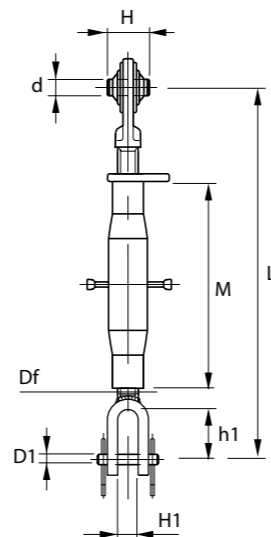

PERNO ZINCATO PER BRACCIO DI SOLLEVAMENTO LATERALE  
LINKAGE PINS

SIGLA ARTICLE	D	L	L1	L2	d	PESO IN Kg. WEIGHT Kg.
PL 11921	18	64	52	6	6	0.12
PL 11922	18	74	62	6	6	0.14
PL 11923	18	84	72	6	6	0.16
PL 11924	18	94	82	6	6	0.18

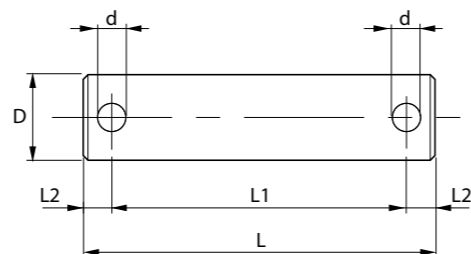

BRACCIO DI SOLLEVAMENTO LATERALE DESTRO REGISTRABILE  
LEVELLING BOX

TRATTORI INFERIORI AI 60 HP - TRACTORS LOWER THAN 60 HP

SIGLA ARTICLE	L		FILETTO INTERNO INNER THREAD	D	D1	H	h	H1	h1	PESO IN Kg. WEIGHT Kg.
	MIN.	MAX								
ML 11950	380	480	M24X2	18	18	44	70	24	72	4.84
ML 11960	450	550	M24X2	18	18	44	70	24	72	5.00
ML 11970	500	600	M24X2	18	18	44	70	24	72	5.30
ML 11972	400	480	M24X2	18	26	44	70	24	93	5.70

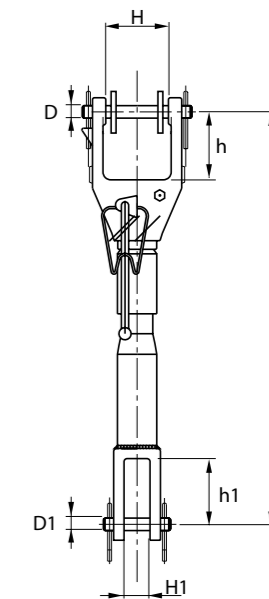

TRATTORI OLTRE I 60 HP - TRACTORS HIGHER THAN 60 HP

SIGLA ARTICLE	L		FILETTO INTERNO INNER THREAD	D	D1	H	h	H1	h1	PESO IN Kg. WEIGHT Kg.
	MIN.	MAX								
ML 11980	515	650	M27X2	24	24	45	80	24	93	7.90
ML 11990	665	800	M27X2	24	24	45	80	24	93	8.60

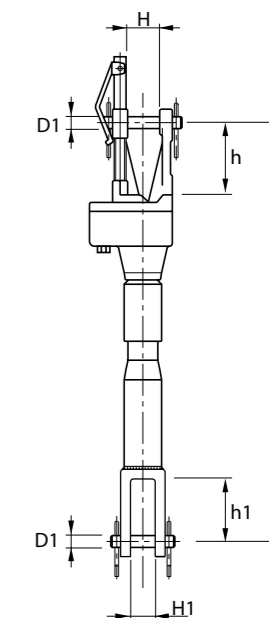

CAVALLOTTO CON PERNO ZINCATO PER ATTREZZI  
AGGANCIABILI AL SOLLEV. DEI TRATTORI  
TOOLS COUPLING FORK

SIGLA ARTICLE	PESO IN Kg. WEIGHT Kg.
CP 11925	0.82

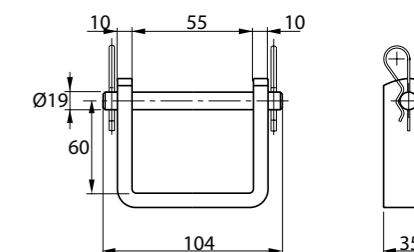

BRACCIO DI SOLLEVAMENTO LATERALE SINISTRO - FIAT  
ADJUSTABLE LEVELLING ARM LHX FIAT

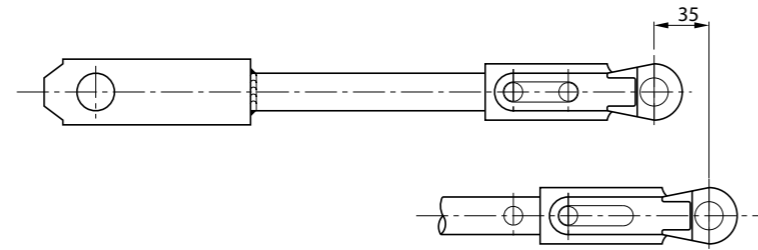
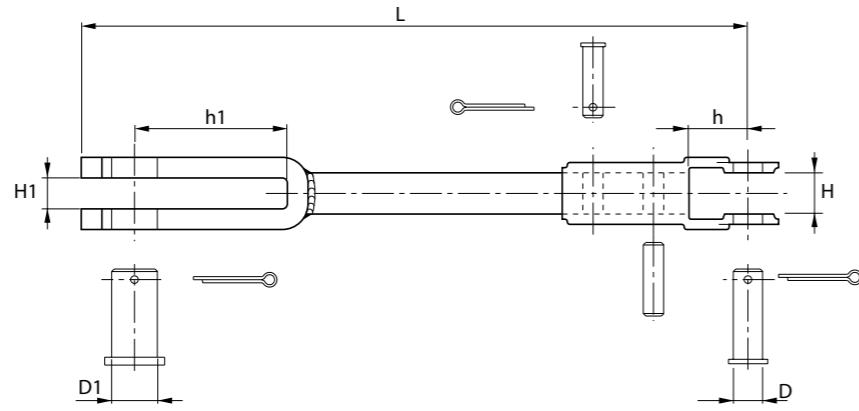

SIGLA ARTICLE	L		D	D1	H	h	H1	h1	IMPIEGO APPLICATION	RIF. ORIGINALE FIAT ORIGINAL "FIAT" REF.	PESO IN Kg. WEIGHT Kg.
	MIN.	MAX									
BLF 12381	375	410	18	18	25	36	24	72	LAT. FIAT 411	586024	2.92
BLF 12382	400	435	18	26	25	36	24	93	LAT. FIAT 605 C	4983310	3.70
SF 12383	RICAMBIO FORCELLA IN GHISA PER BLF 12381 - BLF 12382 SPARE PART CASTING CLEVIS BLF 12381 - BLF 12382										0.78

BARRE DI TRAINO  
DRAWBARS

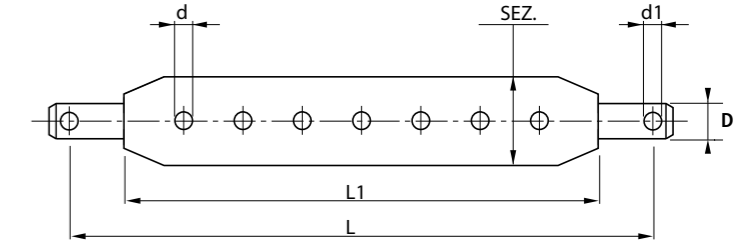

SIGLA ARTICLE	CAT	D	SEZ.	L (±2.5)	L1 (±1.5)	d	N. FORI N. HOLES	d1	PESO IN Kg. WEIGHT Kg.
BT 11850	1	22	70X25	770	680	22	7	11	8.64
BT 11860	2	28	80X30	890	780	28	7	11	12.86

TENDITORI  
ADJUSTERS

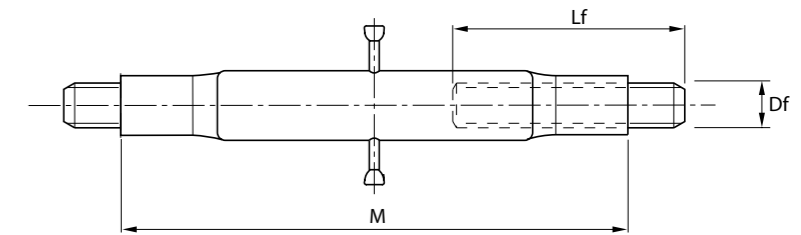

SIGLA ARTICLE	Df	M	Lf	PESO IN Kg. WEIGHT Kg.
TD 11861	M22X2.5	230	110	1.46
TD 11862	M22X2.5	280	110	1.66
TD 11863	M24X2.5	320	130	2.00
TD 11864	M27X3	320	160	2.42
TD 11865	M30X3	360	160	3.08
TD 11866	M30X3	430	160	3.36
TD 11867	M36X3	460	160	4.98

BRACCI DI SOLLEVAMENTO INFERIORE PER TRATTORI FIAT  
LOWER LINK ARMS FOR FIAT TRACTORS

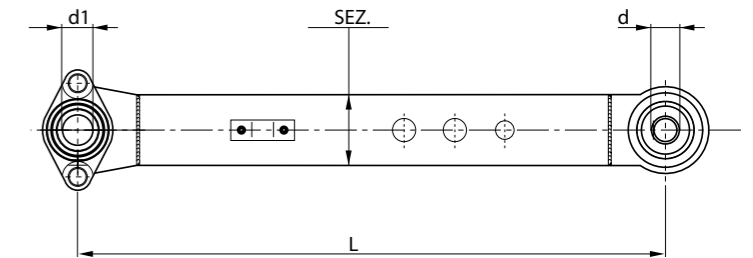

SIGLA ARTICLE	d	d1	L	SEZ.	IMPIEGO TRATTORI TRACTORS TYPE	RIF. ORIGINALE FIAT ORIGINAL "FIAT" REF.	PESO IN Kg. WEIGHT Kg.
BF 12200	22.1	22.1	720	60X20	211 - 215 - 250 - 300	RUOTE - TYRES 4992590 SX - 4992589 DX	7.12
BF 12210	22.1	22.1	770	75X14	350 - 411 - 415 - 450 - 500 - 480	RUOTE - TYRES 595164 - 5104699	6.44
BF 12220	28.4	28.4	940	90X20	512 - 513 - 615 - 715 - 650 - 750	RUOTE - TYRES 595812	14.24
BF 12230	28.4	22.1	940	90X20	550 - 550S - 640	RUOTE - TYRES 4981567	13.94
BF 12240	22.1	22.1	735	75X14	312 - 311 - 355 - 411 - 455	CINGOLI - TRACKS 569242 - 5103005	6.12
BF 12250	22.1	22.1	740	90X20	605-505-555	CINGOLI - TRACKS 4952211	10.60
BF 12260	28.4	22.1	820	75X14	480	RUOTE - TYRES 4982413	7.10
BF 12270	28.4	26	925	100X20	780 - 680 - 880	RUOTE - TYRES 5109973	14.14
BF 12280	28.4	26	960	100X20	70 - 80/70 - 80DT	RUOTE - TYRES 5131564	14.90



CATENE IMBRIGLIAMENTO PER SOLLEVATORI  
SLING CHAINS FOR LIFTS

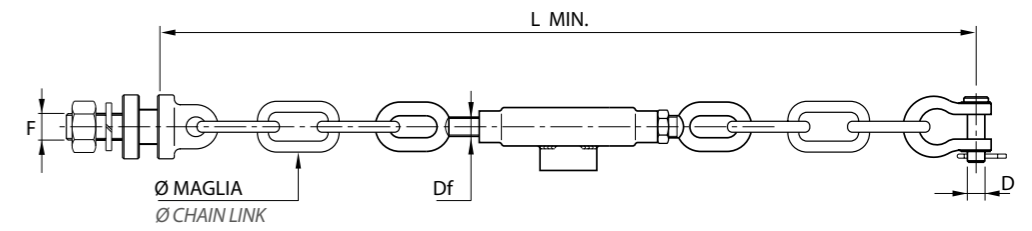

SIGLA ARTICLE	N. MAGLIE N. CHAIN LINK	Ø MAGLIE Ø CHAIN LINK	L MIN.	D	Df	F	IMPIEGO TRATTORI TRACTORS TYPE	PESO IN Kg. WEIGHT Kg.
CS 12100	1+1	12	440	14	M20X2.5	M20	SAME	2.00
CS 12110	2+2	12	570	14	M20X2.5	M20	SAME	2.28
CS 12120	3+3	12	690	14	M20X2.5	M20	SAME	2.60
CS 12130	3+2	12	620	14	M20X2.5	M20	SAME	2.44
CS 12140	3+1	10	460	14	M16X2	M18	SAME	1.56
CS 12142	2+1	14	500	16	M20X2.5	M24	SAME EXPLORER	3.00
CS 12150	3+2	12	620	14	M20X2.5	M20	LANDINI (con piastra) - (with plate)	3.10
CS 12160	2+2	12	570	14	M20X2.5	M20	LANDINI (con piastra) - (with plate)	2.92

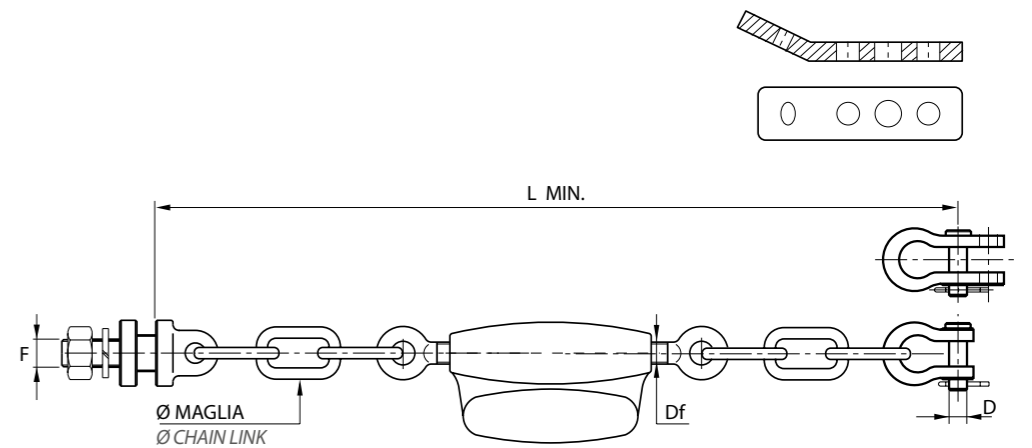

SIGLA ARTICLE	N. MAGLIE N. CHAIN LINK	Ø MAGLIE Ø CHAIN LINK	L MIN.	D	Df	F	IMPIEGO TRATTORI TRACTORS TYPE	RIF. ORIGINALE FIAT ORIGINAL "FIAT" REF.	PESO IN Kg. WEIGHT Kg.
CS 12049	1+1	14	430	14-14	M16X2	M22	FIAT	5130634	2.80
CS 12050	1+1	12	370	14-14	M16X2	M22	FIAT	5131390	2.58
CS 12060	2+1	12	450	14-14	M16X2	M22	FIAT	5116366	2.76
CS 12170	2+2	12	430	12	M16X2	M18	FIAT	5002501	2.50
CS 12180	3+3	12	490	12	M16X2	M18	FIAT	5002499	2.70
CS 12190	4+4	12	570	12	M16X2	M18	FIAT	5002545	3.00
CS 12194	4+3	18	670	16	M22X2.5	M20	FIAT 805	4988796	5.18

MEZZE CATENE "FIAT"  
"FIAT" CHAINS

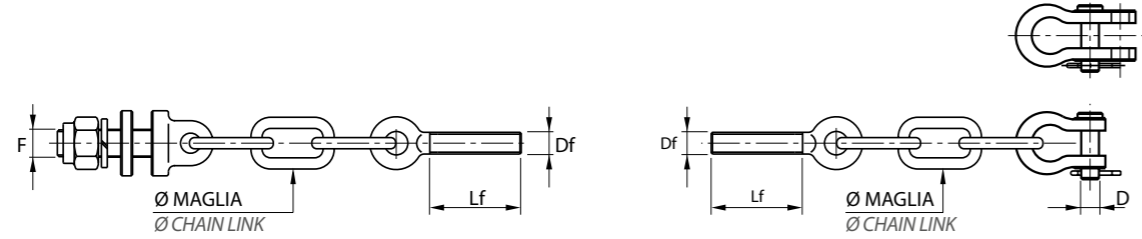

SIGLA ARTICLE	N. MAGLIE N. CHAIN LINK	Ø MAGLIE Ø CHAIN LINK	D	Df	Lf	F	MAGLIA CHAIN	RIF. ORIGINALE FIAT ORIGINAL "FIAT" REF.	PESO IN Kg. WEIGHT Kg.
CP 12251	3	12	-	M16X2 SX	75	M18X1.5	CS12180	595165	1.10
CG 12261	3	12	12	M16X2 DX	75	-	CS12180	571441	0.70
CP 12253	2	12	-	M16X2 DX	95	M22X1.5	CS12060	5116090	1.16
CG 12263	1	12	14-14	M16X2 SX	95	-	CS12060	5112029	0.70
CP 12255	1	12	-	M16X2 DX	75	M22X1.5	CS12050	5131403	1.00
CG 12265	1	12	14-14	M16X2 SX	75	-	CS12050	5131402	0.68
CP 12257	1	14	-	M16X2 DX	75	M22X1.5	CS12049	5130652	1.12
CG 12267	1	14	14-14	M16X2 SX	75	-	CS12049	5121161	0.78
CP 12258	2	12	-	M16X2 SX	75	M18X1.5	CS12170	4969215	1.00
CG 12268	2	12	12	M16X2 DX	75	-	CS12170	4969214	0.60
CP 12259	4	12	-	M16X2 SX	75	M18X1.5	CS12190	505048	1.28
CG 12269	4	12	12	M16X2 DX	75	-	CS12190	4988445	0.86

MANICOTTO IN GHISA M16X2 PER CATENE "FIAT"  
CAST IRON TUBE FOR "FIAT" CHAINS

SIGLA ARTICLE	IMPIEGO CATENE CHAIN APPLICATION	PESO IN Kg. WEIGHT Kg.
MG 12271	CS 12049 - CS 12050 - CS 12060 - CS 12170 - CS 12180 - CS 12190	0.90

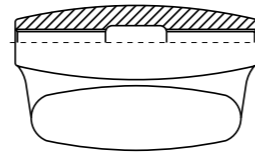

SUPPORTO PER L'ATTACCO DELLE CATENE PORTA ATTREZZI  
HOUSING FOR THE IMPLEMENT MOUNTING PIN FOR TOOLS CHAINS

SIGLA ARTICLE	IMPIEGO TRATTORI TRACTORS TYPE	PESO IN Kg. WEIGHT Kg.
AC 12275	FIAT C 455 - FIAT C 505 - FIAT C 605	1.34

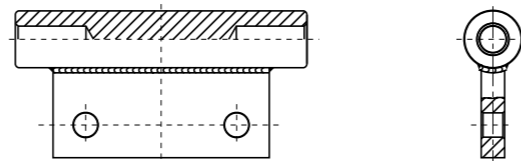

MANICOTTI CON TENDITORI PER CATENE IMBRIGLIAMENTO  
ADJUSTERS FOR STABILISERS

SIGLA ARTICLE	Df	L MIN.	M	Dt	d	PESO IN Kg. WEIGHT Kg.
MT 11590	M14X2	230	130	32	12	0.76
MT 11600	M16X2	230	130	35	15	0.78
MT 11610	M18X2.5	235	130	38	15	0.96
MT 11620	M20X2.5	270	130	36	14	1.10
MT 11630	M22X2.5	280	150	38	14	1.26

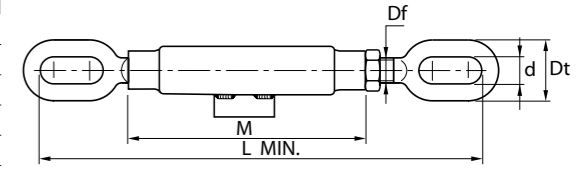

SIGLA ARTICLE	Df	L MIN.	M	Dt	d	PESO IN Kg. WEIGHT Kg.
MT 11615	M16X2	200	130	46	18	0.88
MT 11625	M20X2.5	230	130	44	18	1.14
MT 11635	M22X2.5	230	150	50	20	1.36

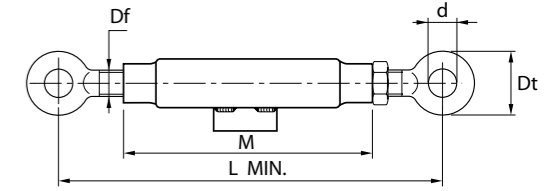

TIRANTI FILETTATI CON TESTA AD ASOLA E TONDA PER MANICOTTI  
ROUND AND EYELET HEAD SHAPED FOR HUFFS

SIGLA ARTICLE	Df	L	Lf	d	d1	Dt	PESO IN Kg. WEIGHT Kg.
TMA 12370	M14X2 DX	109	65	12	30	32	0.14
TMA 12371	M14X2 SX	109	65	12	30	32	0.14
TMA 12372	M16X2 DX	107	70	15	30	35	0.17
TMA 12373	M16X2 SX	107	70	15	30	35	0.17
TMA 12374	M18X2.5 DX	110	70	15	30	38	0.23
TMA 12375	M18X2.5 SX	110	70	15	30	38	0.23
TMA 12376	M20X2.5 DX	126	75	14	43	36	0.28
TMA 12377	M20X2.5 SX	126	75	14	43	36	0.28
TMA 12378	M22X2.5 DX	130	80	14	43	38	0.34
TMA 12379	M22X2.5 SX	130	80	14	43	38	0.34

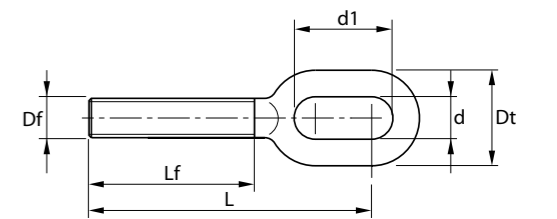

SIGLA ARTICLE	Df	L	Lf	d	Dt	PESO IN Kg. WEIGHT Kg.
TMO 12372	M16X2 DX	98	70	18	46	0.22
TMO 12373	M16X2 SX	98	70	18	46	0.22
TMO 12376	M20X2.5 DX	115	85	18	44	0.30
TMO 12377	M20X2.5 SX	115	85	18	44	0.30
TMO 12378	M22X2.5 DX	115	85	20	50	0.36
TMO 12379	M22X2.5 SX	115	85	20	50	0.36

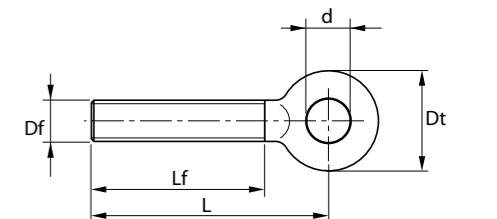

GRILLI ZINCATI CON PERNO E COPIGLIA  
SHACKLE WITH PIN

SIGLA ARTICLE	D POLLICI INCHES	D mm.	A	L	H	H1	CARICO LAVORO WORKING LOAD Kg.	PESO IN Kg. WEIGHT Kg.
GP 11700	1/2"	12	18	34	40	-	850	0.18
GP 11710	9/16"	14	18	34	40	-	850	0.20
GP 11720	5/8"	16	20	40	54	-	950	0.30
GP 11740	5/8"	16	20	46	40	-	1200	0.40
GP 11730	9/16"	14-14	18	38	50	72	850	0.34

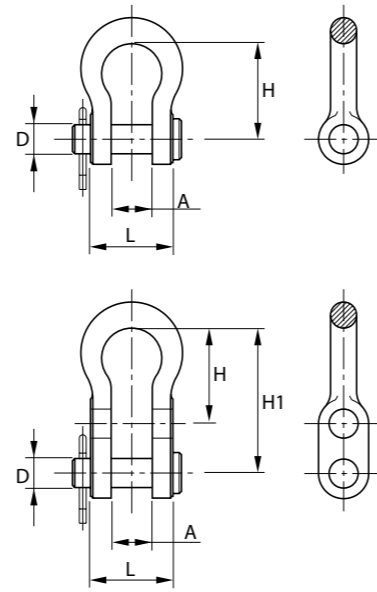

PERNI PER GRILLI  
"D" SHACKLE PINS

SIGLA ARTICLE	D	D1	L	L1	h	L2	d	PESO IN Kg. WEIGHT Kg.
PZ 11750	12	16	50	47	3	40	4	0.05
PZ 11760	14	18	50	47	3	40	4	0.06
PZ 11770	16	20	53	50	3	44	4	0.08
PZ 11771	16	21	63	60	3	50	4	0.10

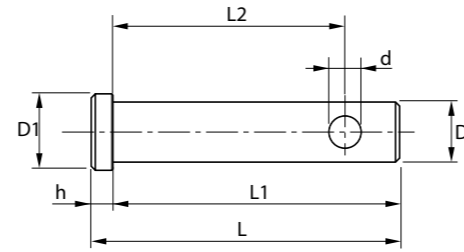

PERNO AD OCCHIO CON DADO PER CATENE IMBRIGLIAMENTO  
EYEBOLT FOR STABILISERS

SIGLA ARTICLE	F	L	L1	R	Dt	D	d	H	PESO IN Kg. WEIGHT Kg.
PO 11800	M16X2	65	44	18	36	16	15	11	0.22
PO 11810	M18X2.5	65	44	18	36	18	15	11	0.26
PO 11820	M20X2.5	80	58	21	42	20	18	12	0.40
PO 11830	M24X2	105	65	21	54	24	24	26	0.82
PO 11831	M20X2.5	105	65	21	54	20	20	26	0.72

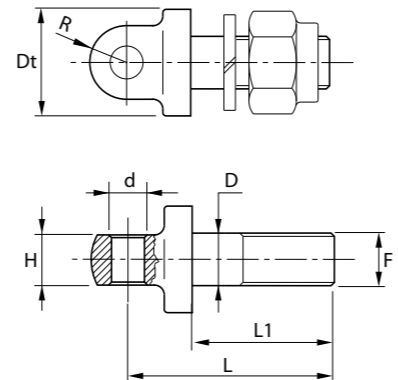

PERNO PER ATTACCO ATTREZZI  
IMPLEMENT MOUNTING PIN

SIGLA ARTICLE	D	D1	L1	L2	L3	L4	Df	Lf	d	D3	L	IMPIEGO APPLICATION	PESO IN Kg. WEIGHT Kg.
PA 11000	22	28	74	14	50	54	M22X1.5	40	12	38	140	UNIVERSALE - GENERAL	0.54
PA 11010	28	28	78	20	60	60	M22X1.5	40	12	44	150	UNIVERSALE - GENERAL	0.80
PA 11020	22	22	74	14	50	54	M22X1.5	40	12	38	140	UNIVERSALE - GENERAL	0.52
PA 11025	22	20	74	14	50	54	M20X1.5	40	12	38	140	UNIVERSALE - GENERAL	0.50
PA 11030	28	22	78	14	60	60	M22X1.5	46	12	44	150	UNIVERSALE - GENERAL	0.76
PA 11035	22	30	78	12	52	46	M30X2	34	12	42	136	CELLI	0.82
PA 11036	28	30	78	12	52	46	M30X2	34	12	42	136	CELLI	0.98
PA 11038	22	24	74	14	50	54	M22X1.5	40	12	38	140	MASCHIO	0.52
PA 11040	28	24	78	18	60	60	M22X1.5	42	12	44	150	MASCHIO	0.72
PA 11042	22	25	74	14	50	54	M22X1.5	40	12	38	140	SICMA	0.54
PA 11044	28	25	78	14	60	60	M22X1.5	46	12	44	150	SICMA	0.72
PA 11046	22	27	74	14	50	54	M22X1.5	40	12	38	140	NARDI	0.54
PA 11048	28	27	78	18	60	60	M22X1.5	42	12	44	150	NARDI	0.74

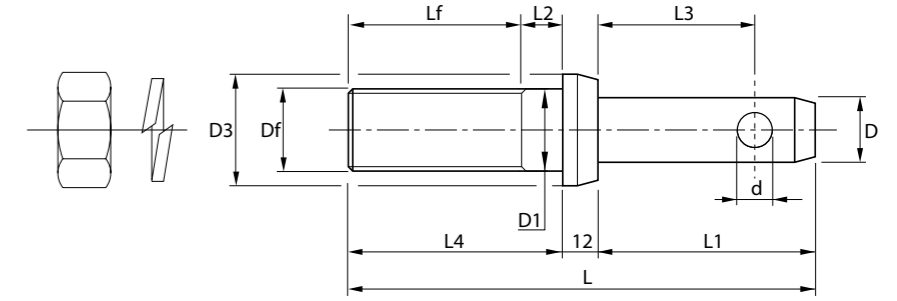

PERNO DOPPIO PER ATTACCO ATTREZZI  
DOUBLE IMPLEMENT MOUNTING PIN

SIGLA ARTICLE	D	D1	D2	L1	L2	L3	L4	L5	Df	Lf	d	D3	L	PESO IN Kg. WEIGHT Kg.
PD 11050	28	28	22	79	14	48	58	108	M27X3	28	12	44	199	0.96
PD 11060	28	25	22	79	14	48	58	108	M24X2	28	12	44	199	0.96

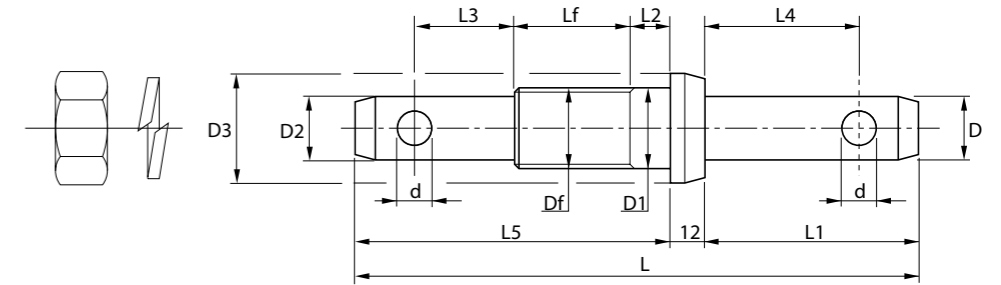

**PERNO INTERCAMBIABILE PER ATTACCO ATTREZZI**  
*INTERCHANGEABLE IMPLEMENT MOUNTING PIN*

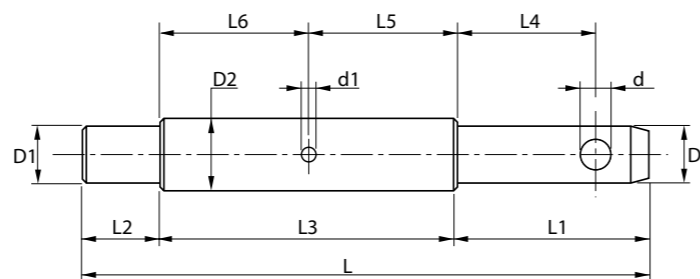

SIGLA ARTICLE	D	D1	D2	L	L1	L2	L3	L4	L5	L6	d	d1	RIF. ORIGINALE FIAT ORIGINAL "FIAT" REF.	PESO IN Kg. WEIGHT Kg.
PA 11100	22	22	28	201.5	56.5	30	115	38.5	67	48	12	6.3	4954459	0.78
PA 11110	25	22	28	193	53	25	115	38.5	67	48	12	6.3	5102993	0.80

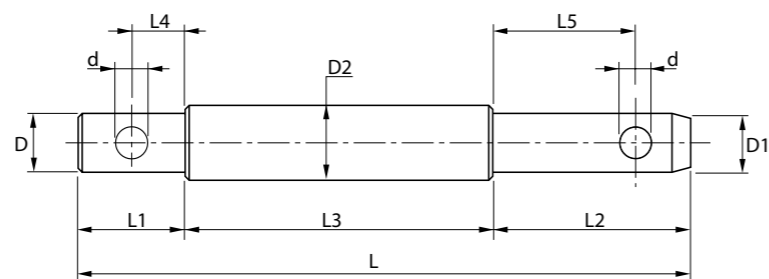

SIGLA ARTICLE	D	D1	D2	L	L1	L2	L3	L4	L5	d	PESO IN Kg. WEIGHT Kg.
PA 11140	22	22	28	210	40	100	70	20	80	12	0.72
PA 11150	19	19	25	210	40	100	70	20	80	12	0.54

**PERNO PER ATTACCO ATTREZZI SU TRATTORI FIAT**  
*IMPLEMENT MOUNTING PIN FOR FIAT TRACTORS*

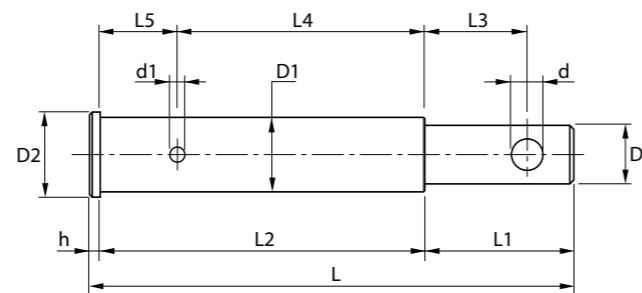

SIGLA ARTICLE	D	D1	D2	L	L1	L2	h	L3	L4	L5	d	d1	RIF. ORIGINALE FIAT ORIGINAL "FIAT" REF.	PESO IN Kg. WEIGHT Kg.
PA 11170	22	28	32	182.5	56.5	122	4	38.5	93.5	28.5	12	6.3	4954461	0.74
PA 11180	22	28	32	172.5	56.5	112	4	38.5	83.5	28.5	12	6.3	4954462	0.69

**PERNO DOPPIO DA SALDARE PER ATTACCO ATTREZZI**  
*WELD ON IMPLEMENT MOUNTING PIN*

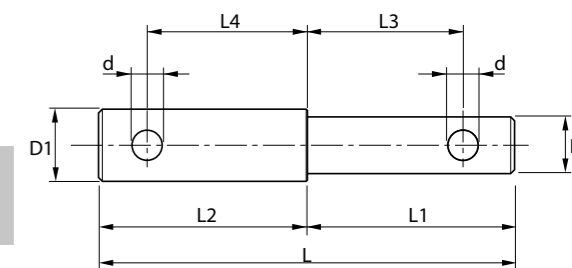

SIGLA ARTICLE	D	D1	L	L1	L2	L3	L4	d	PESO IN Kg. WEIGHT Kg.
PS 11200	22	28	190	105	85	85	62	12	0.68

**PERNO UNIVERSALE**  
*IMPLEMENT PIN*

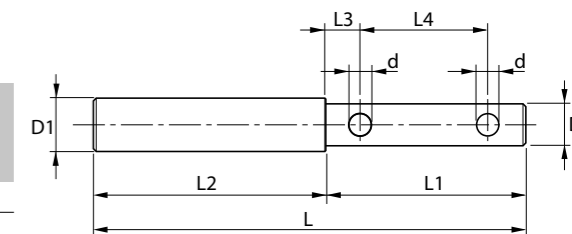

SIGLA ARTICLE	D	D1	L	L1	L2	L3	L4	d	PESO IN Kg. WEIGHT Kg.
PS 11203	19	25	180	90	90	18	57	5	0.54
PS 11204	22	28	180	90	90	18	57	5	0.68

**PERNO D'ATTACCO DA SALDARE**  
*WELD ON LINK PIN*

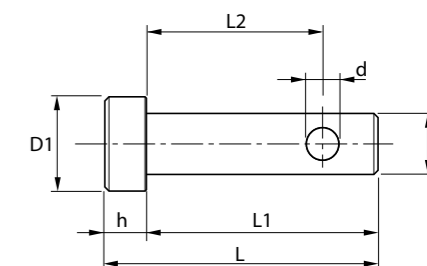

SIGLA ARTICLE	D	D1	L	L1	h	L2	d	PESO IN Kg. WEIGHT Kg.
PS 11210	22	28	95	80	15	60	11.5	0.30
PS 11220	28	34	95	80	15	60	11.5	0.47



PERNO PER 3° PUNTO COMPLETO DI CATENA E SPINA A SCATTO  
TOP LINK PIN WITH CHAIN AND LINCH PIN

SIGLA ARTICLE	CAT.	D	L	L1	d	D1	L2	PESO IN Kg. WEIGHT Kg.
PP 11300	1	19	110	95	11	10	46	0.34
PP 11310	2	25	115	100	11	10	46	0.56

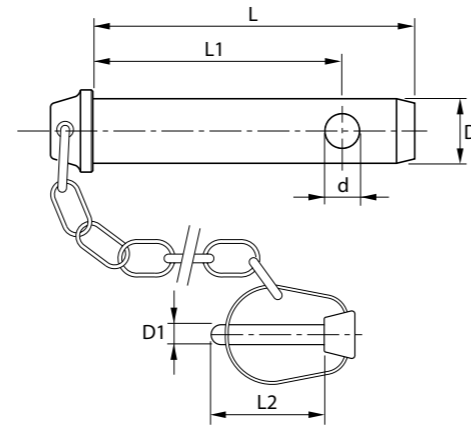

PERNO PER 3° PUNTO SENZA CATENA E SENZA SPINA  
TOP LINK PIN WITHOUT CHAIN AND WITHOUT LINCH PIN

SIGLA ARTICLE	CAT.	D	L	L1	h	D1	d	PESO IN Kg. WEIGHT Kg.
PP 11320	1	19	125	85	15	25	12	0.27
PP 11330	2	25	135	95	15	30	12	0.54
PP 11335	3	32	152	105	20	38	12	0.96

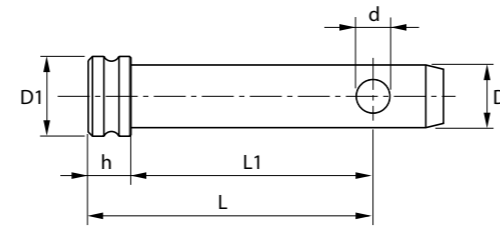

SIGLA ARTICLE	CAT.	D	L	L1	L2	d	PESO IN Kg. WEIGHT Kg.
SP 11400	1	19	140	96	22	12	0.26
SP 11410	1	19	170	126	22	12	0.34
SP 11420	1	19	207	163	22	12	0.42
SP 11430	1	19	254	210	22	12	0.52
SP 11450	2	25	144	100	22	12	0.52
SP 11460	2	25	164	120	22	12	0.56
SP 11470	2	25	210	166	22	12	0.76
SP 11480	2	25	254	210	22	12	0.92
SP 11490	2	25	294	250	22	12	1.10

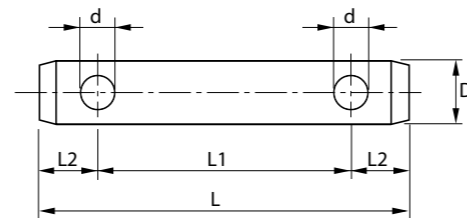

PERNO ATTACCO ATTREZZI LANDINI - LAMBORGHINI CINGOLO  
IMPLEMENT MOUNTING PIN - LANDINI LAMBORGHINI C.

SIGLA ARTICLE	D	D1	D2	L	L1	L2	L3	L4	L5	L6	Df	d	IMPIEGO APPLICATION	PESO IN Kg. WEIGHT Kg.
PL 11031	28	20	36	186	64	22	100	50	18	82	M10X1.5	12	LANDINI C. 4500- C. 5000	1.10
PL 11032	28	20	35	187	63	22	102	50	20	82	*M12X1.25	12	LAMBORGHINI C.	1.06
PL 11033	22	20	30	175	53	22	100	40	17	83	M10X1.5	12	LAMBORGHINI C.	0.72

(\*) A RICHIESTA M14  
(\*) ON REQUEST M14

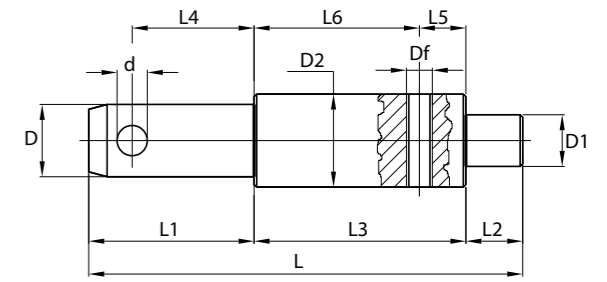

PERNO FRESA MASCHIO  
PIN FOR MALE CUTTER

SIGLA ARTICLE	D	L	L1	L2	S3	d	PESO IN Kg. WEIGHT Kg.
PM 12350	22	130	93	12	12	12	0.36
PM 12352	28	143	100	18	12	12	0.66

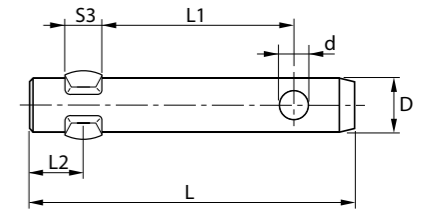

PERNO TRAINO FIAT  
PIN "FIAT"

SIGLA ARTICLE	D	D1	L	L1	L2	RIF. ORIGINALE FIAT ORIGINAL "FIAT" REF.	PESO IN Kg. WEIGHT Kg.
PTF 1945	28	37	170	138	32	5130629	0.90

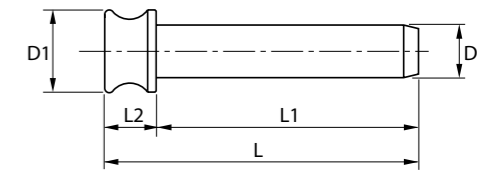

PERNO ATTACCO FIAT  
LINKAGE PIN FIAT TYPE

SIGLA ARTICLE	RIF. ORIGINALE FIAT ORIGINAL "FIAT" REF.	PESO IN Kg. WEIGHT Kg.
PF 11182	579877	0.30

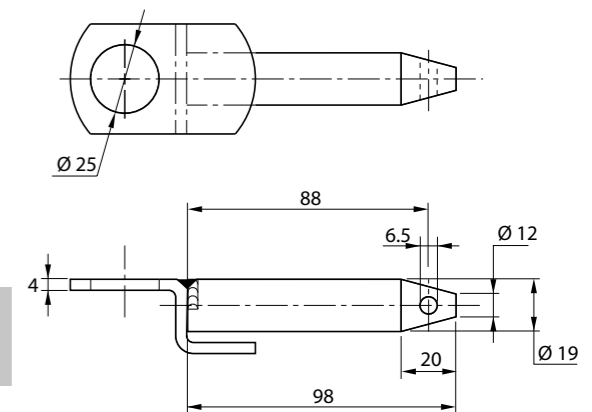

PERNO PER FORCELLE TIRANTI REGOLABILI DX - SX  
PIN FOR SHIFTERS TO BE REGULATED RHS-LHS

SIGLA ARTICLE	D	L	L1	L2	d	IMPIEGO APPLICATION	PESO IN Kg. WEIGHT Kg.
PF 12310	20	71	58	6.5	6		0.17
PF 12311	20	81	68	6.5	6		0.19
PF 12312	22	64	52	6	6		0.18
PF 12313	24	90	77	6.5	6		0.30
PF 12314	24	104	91	6.5	6	ML11980 - ML 11990	0.36
PF 12315	26	68	56	6	6	ML11972- BFL 12382	0.28
PF 12316	28	110	93	8.5	6	FC 10464	0.52
PF 12324	24	81	65	8	6	SL 12010 SL 12020 SL 12030 SL 12040	0.29

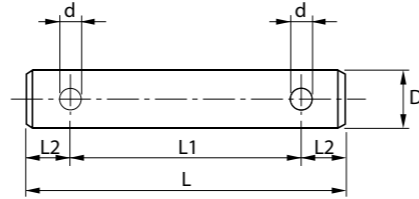

SIGLA ARTICLE	D	L	L1	L2	d	Q	H	PESO IN Kg. WEIGHT Kg.
PF 12317	18	91.5	83.5	77	6	8	60	0.19
PF 12318	19	91.5	83.5	77	6	8	60	0.20
PF 12319	20	91.5	83.5	77	6	8	60	0.23
PF 12320	24	98.5	90.5	84	6	8	60	0.35
PF 12321	24	100	92.5	87	6	8	60	0.36

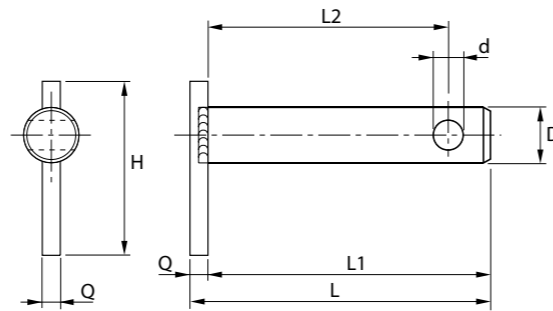

SIGLA ARTICLE	D	L	L1	L2	d	S	B X H	PESO IN Kg. WEIGHT Kg.
PF 12322	19	110	100	88	10	8	40X65	0.38
PF 12323	24	110	100	88	6	8	40X65	0.52

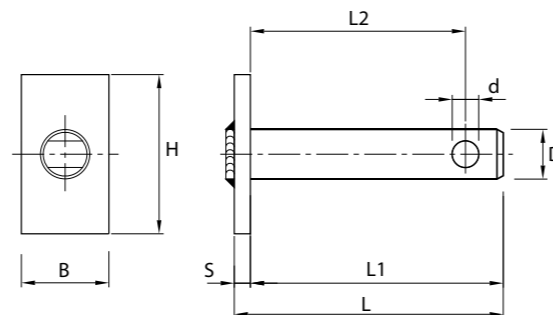

PERNI TESTA QUADRA "FIAT"  
SQUARE PIN "FIAT"

SIGLA ARTICLE	D	Q	L	L1	S	L2	d	PESO IN Kg. WEIGHT Kg.
PF 11183	18	20	52	47	5	41	6	0.10
PF 11185	18	20	65	60	5	54	6	0.14
PF 11187	26	30	65	60	5	52	6	0.28
PF 11189	26	30	75	70	5	60	6	0.32
PF 11191	26	30	100	95	5	86	6	0.34
PF 11192	22	25	100	92	8	78	6	0.30
PF 11193	22	25	110	102	8	85	6	0.42
PF 11194	28	34	95	90	5	80	6	0.60
PF 11195	28	34	105	100	5	90	6	0.65

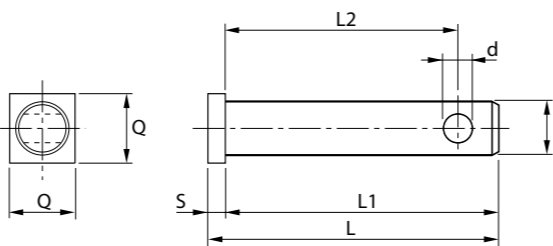

SPINOTTO DI TRAZIONE  
PINS

SIGLA ARTICLE	D	L	L1	d	PESO IN Kg. WEIGHT Kg.
ST 12355	16	115	100	8.5	0.30
ST 12356	18	115	100	8.5	0.36
ST 12357	20	135	120	8.5	0.46
ST 12358	22	135	120	12	0.52
ST 12359	24	135	120	12	0.60
ST 12360	26	175	160	12	0.84
ST 12361	28	135	120	12	0.76
ST 12362	28	175	160	12	0.96
ST 12363	30	175	160	12	1.08
ST 12364	32	180	165	12	1.24

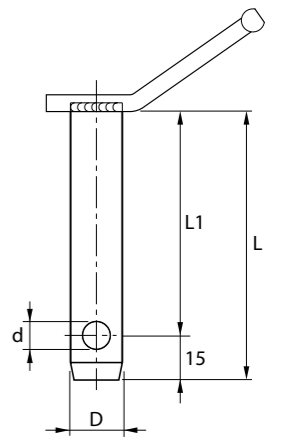

SPINOTTO CON MANIGLIA  
HITCH PINS

SIGLA ARTICLE	D	L	L1	d	PESO IN Kg. WEIGHT Kg.
SM 1926	19	125	110	12	0.34
SM 1928	19	180	165	12	0.48
SM 1930	22	135	120	12	0.48
SM 1932	22	180	165	12	0.62
SM 1933	25	135	120	12	0.62
SM 1935	25	180	165	12	0.78
SM 1936	28	135	120	12	0.76
SM 1938	28	180	165	12	0.98
SM 1939	30	180	165	12	1.10
SM 1941	32	180	165	12	1.26

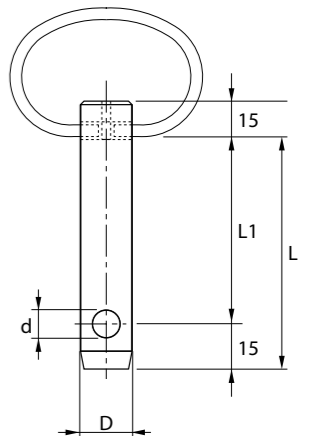

SPINOTTO D'ATTACCO CON CATENA  
HITCH PINS WITH CHAIN

SIGLA ARTICLE	D	L	L1	d	D1	L2	PESO IN Kg. WEIGHT Kg.
SA 11350	19	125	110	6.5	6	42	0.44
SA 11352	19	175	160	6.5	6	42	0.54
SA 11354	22	175	160	6.5	6	42	0.76
SA 11356	25	175	160	6.5	6	42	0.90
SA 11358	28	135	120	10.5	10	46	0.88
SA 11360	28	175	160	6.5	6	42	1.10
SA 11362	32	180	165	10.5	10	46	1.50

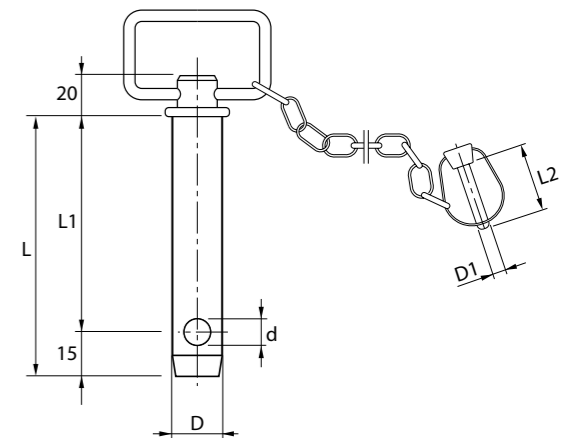

SPINE A SCATTO  
LINCH PINS

SIGLA ARTICLE	D	L	L2	D1	L1	ALBERO SHAFT Ø
SS 00090	4,5	34	6,5	2	29	10 ÷ 15
SS 00092	5	46	7	2,4	34	14 ÷ 18
SS 00094	6	48	8	2,4	32	18 ÷ 22
SS 00096	7	54	9	3	36	20 ÷ 24
SS 00098	8	56	10	3,4	38	22 ÷ 28
SS 00100	9	58	12	3,4	39	26 ÷ 32
SS 00102	10	58	12	3,4	39	28 ÷ 36
SS 00104	11	58	12	3,4	36	32 ÷ 34

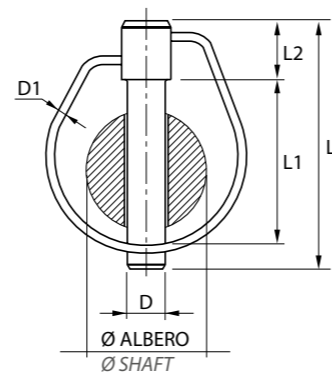

SPINA A SCATTO Ø 11 - Ø 16 PER CONO GUIDA ATTACCO RAPIDO  
LINCH PINS Ø11 - Ø16 WITH CHAIN

SIGLA ARTICLE	D	L	L2	D1	L1	ALBERO SHAFT Ø
SS 00105*	11	70	17	4	48	36 ÷ 42
SS 00106	11	70	17	4	48	36 ÷ 42
SS 00117*	16	80	25	4	48	36 ÷ 42
SS 00118	16	80	25	4	48	36 ÷ 42

\*CON CATENELLA  
\*WITH CHAIN

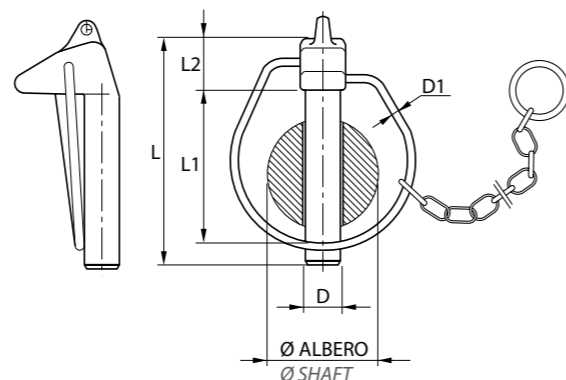

SPINA A SCATTO A TESTA QUADRA CON CATENA  
SQUARE LINCH PIN WITH CHAIN

SIGLA ARTICLE	D	L	Q
107 SSC	12	55	18
108 SSC	14	55	18
110 SSC	16	55	20
112 SSC	19	75	25

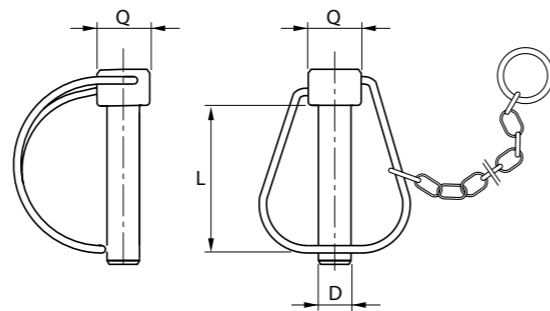

SPINA DI SICUREZZA  
SAFETY LINCH PIN

SIGLA ARTICLE	D	L	L2	L1	D1	ALBERO SHAFT Ø
114 SS	11	64	14	42	3	30 ÷ 42

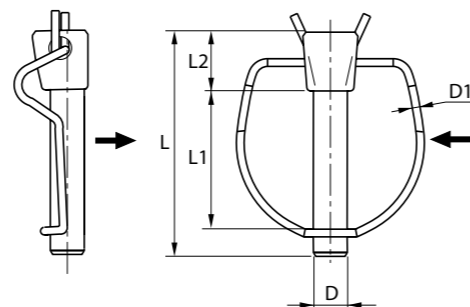

COPIGLIE A FORCELLA - TIPO FIAT  
CLIPS-FIAT

SIGLA ARTICLE	D	L
CF 00060	3 X 1,5	36
CF 00061	5 X 2,5	56

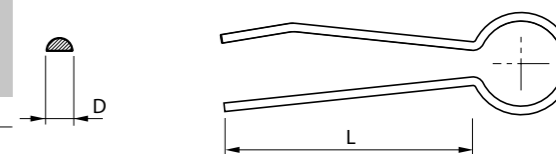

COPIGLIE A MOLLA - TIPO R  
GRIP CLIPS

SIGLA ARTICLE	D	L	ALBERO SHAFT Ø
CM 00040	1,8	38	da 6 a 8 from 6 to 8
CM 00042	2	46	da 10 a 12 from 10 to 12
CM 00044	2,5	62	da 11 a 13 from 11 to 13
CM 00046	3	62	da 12 a 16 from 12 to 16
CM 00048	3,5	72	da 15 a 21 from 15 to 21
CM 00050	4	82	da 16 a 30 from 16 to 30
CM 00052	5	100	da 20 a 35 from 20 to 35
CM 00054	6	105	da 28 a 45 from 28 to 45
CM 00056	7	160	da 40 a 50 from 40 to 50
CM 00058	8	165	da 40 a 55 from 40 to 55

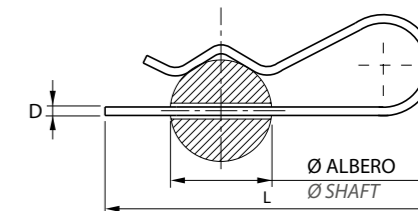

COPIGLIE A MOLLA DOPPIO GIRO - TIPO R  
DOUBLE GRIP-CLIPS

SIGLA ARTICLE	D	L	ALBERO SHAFT Ø
CD 00080	3	84	da 12 a 16 from 12 to 16
CD 00082	3,5	85	da 15 a 21 from 15 to 21
CD 00062	4	98	da 16 a 30 from 16 to 30
CD 00084	4,5	100	da 18 a 30 from 18 to 30
CD 00064	5	110	da 20 a 35 from 20 to 35
CD 00066	6	130	da 28 a 45 from 28 to 45
CD 00086	7	155	da 40 a 50 from 40 to 50

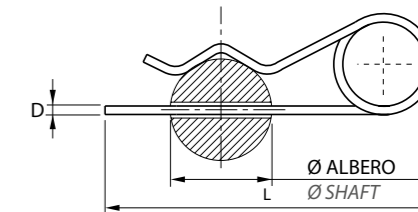

MOLLE FERMAGANCI  
STOP SPRINGS

SIGLA ARTICLE	D	L
MF 00068	3	60
MF 00070	4	100
MF 00072	5	90
MF 00074	6	100

NOTE: CONSIGLIATE PER LA CHIUSURA DELLE SPONDE DA RIMORCHIO.  
NOTE: FOR TRAILER SIDE DOORS

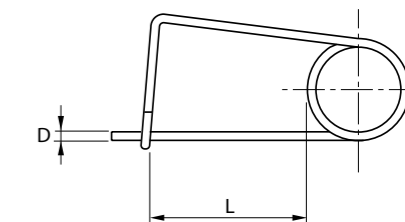

SPINOTTI PER MOTOZAPPA  
SHAFT LOCKING PINS

SIGLA ARTICLE	D	L	L1
SM 00073	6	50	40
SM 00075	8	70	56
SM 00076	8	45	40
SM 00078	10	45	40
SM 00079	10	70	56
SM 00077	12	70	56
SM 00081	12	90	70

NOTE: MATERIALE C40 BONIFICATO  
NOTE: MATERIAL C40 HARDENED AND TEMPERED

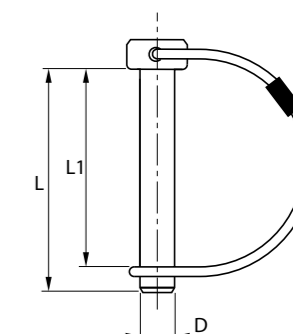

**BASI OSCILLANTI**  
**SWINGING ENDS**

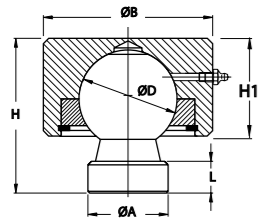

**BO...**

BASE OSCILLANTE  
SWINGING END



SIGLA ARTICLE	ØD	ØA	ØB	H	H1	L	CARICO LIMITE LOAD FACTORS	α	PESO IN Kg. WEIGHT Kg.	
							TON.			
mm.							TON.			
BO 1803	50	40	85	82	45	20	9.60	38	2.20	
BO 1804	60	50	98	100	50	25	15.70	40	3.40	
BO 1805	70	60	105	115	60	30	18.90	38	4.82	

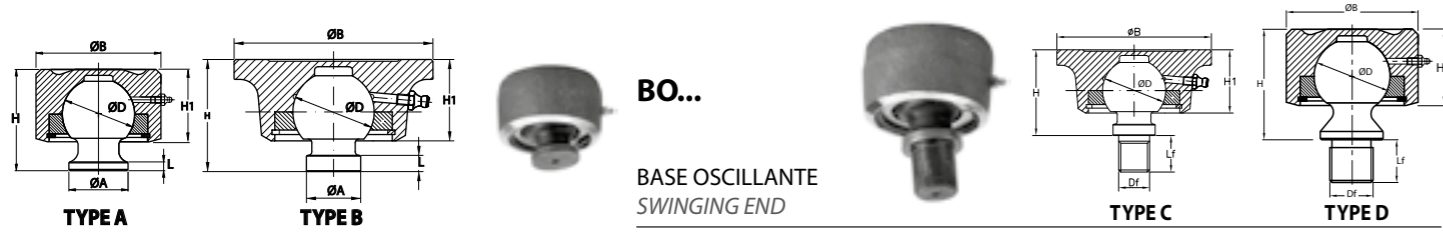

**BO...**

BASE OSCILLANTE  
SWINGING END

SIGLA ARTICLE	ØD	ØA	ØB	H	H1	L	Df	Lf	CARICO LIMITE LOAD FACTORS	TYPE	α	PESO IN Kg. WEIGHT Kg.
									TON.			
mm.									TON.			
BO 1980	45	30	110	62	45	9	-	-	11.0	B	35	2.20
BO 1982	55	45	95	78	55	8	-	-	15.0	A	30	2.88
BO 1984	65	64	107	88	58	9	-	-	23.0	A	30	3.96
BO 1986	45	30	110	61	45	-	M22X1.5	26	11.0	C	32	2.28
BO 1988	55	45	95	78	55	-	M32X2	35	15.0	D	30	3.10

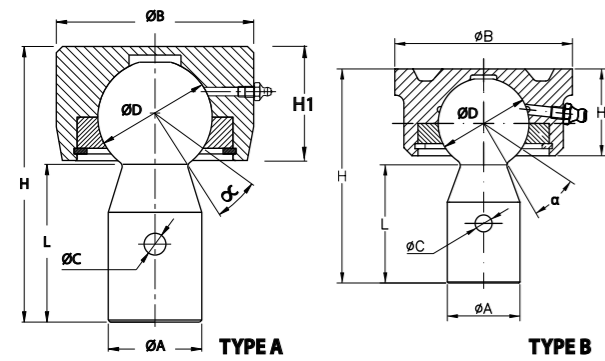

**BO...**

BASE OSCILLANTE  
SWINGING END



SIGLA ARTICLE	ØD	ØA	ØB	ØC	H	H1	L	CARICO LIMITE LOAD FACTORS	TYPE	α	PESO IN Kg. WEIGHT Kg.	
								TON.				
mm.								TON.				
BO 1700 (1)	45	36	88	-	106	43	64	8.0	B	22	2.18	
BO 1701 (1)	45	36	88	8.4	106	43	58.5	8.0	B	36	2.40	
BO 1702 (1)	55	36	92	8.4	118.5	53.5	62	14.0	A	33	3.10	

(1) L'INGRASSATORE È INCLINATO DI CIRCA 6° PER FAVORIRE L'INGRASSAGGIO.  
(1) THE GREASE NIPPLES IS TILTED ABOUT 6° TO HELP THE LUBRICATION.



# THE LEADING GLOBAL MANUFACTURER



TS...C

TS...N

TAPR...S  
ISO 8133

TAPR...CE  
ISO 8132

TAPR...U

TFI...FK

TFE...MK



IS  
ISO 8132

ISS

IKB  
ISO 8132

IKA  
ISO 8132

DK  
DIN 24556

IF  
ISO 8132

QUALITY SYSTEM CERTIFIED  
SISTEMA QUALITÀ CERTIFICATO



Cert Nr 50 100 1557

Everywhere you are, Pavarini Components is at your side  
Ovunque voi siate, Pavarini Components c'è



Registered catalogue. Any reproduction of this catalogue, even if partial, is strictly forbidden.  
Catalogo depositato. È vietata la riproduzione anche parziale di qualsiasi parte del presente catalogo.



7.800.0317 REL. 006 12-09

**pavarini**  
COMPONENTS /spa

46020 PEGOGNAGA - MANTOVA - ITALY - STRADA CÀ BRUCIATA, 5 - TEL. +39 0376-554511 - FAX +39 0376-558606

[www.pavarinicomponents.com](http://www.pavarinicomponents.com) - email: [info@pavarinicomponents.com](mailto:info@pavarinicomponents.com)